

# Installation, Operation and Maintenance Manual

## Series PWBWIRONZ Filter Systems

### PURE WATER

#### ⚠ Warning

You are required to thoroughly read all installation instructions and product instructions and product safety information before beginning the installation of this product. **FAILURE TO COMPLY WITH PROPER INSTALLATION AND MAINTENANCE INSTRUCTIONS COULD RESULT IN PROPERTY DAMAGE, PERSONAL INJURY AND/OR DEATH.** Watts is not responsible for damages resulting from improper installation and/or maintenance.

**Do not use with water that is microbiologically unsafe or of unknown quality without adequate disinfection before or after the system.**

Local building or plumbing codes may require modifications to the information provided. You are required to consult the local building and plumbing codes prior to installation. If this information is not consistent with local building or plumbing codes, the local codes should be followed.

#### Save manual for future reference

Refer to enclosed warranty for operating parameters to ensure proper use with your water supply.



PWBWIRONZ

#### Table of Contents

Important Safety Information - Read All . . . . .	2
Instructions Before Using . . . . .	2
Filter Anatomy . . . . .	2
Specifications . . . . .	3
Feed Water Parameters . . . . .	3
Power . . . . .	3
System Overview . . . . .	3
Installation - Set Up . . . . .	4
Installation - Overview . . . . .	4
Control Valve Component Identification . . . . .	4
Deflector Installation . . . . .	4
Installation - Considerations . . . . .	5
Drain Requirements . . . . .	5
Installation . . . . .	5
Programming . . . . .	7
Controller Operation . . . . .	7
Troubleshooting . . . . .	8
Limited Warranty . . . . .	8

# I. Important Safety Information – Read All

**CAUTION:** Read and follow the information in this manual to minimize the risk of electric shock or personal injury.

**Important:** If you are unsure about installing your Watts water filter, contact a Watts representative or consult a professional plumber.

## A. READ Instructions Before Using

- After reading these instructions completely, obtain all the materials and tools needed for installation.

**NOTE:** Failure to install the system correctly voids the warranty.

- Perform installation according to state, province and local plumbing codes.
  - Use only lead-free solder and flux for sweat-solder connections, as required by state, province and federal codes.
- Handle all components of the system with care. Do not drop, drag or turn components upside down.
- Be sure the floor under the water filter system is clean, level and strong enough to support the unit.
- The system uses 24 volt-60Hz electrical power. Always use the transformer supplied.

Plug transformer into an indoor 120 VAC, grounded outlet. Properly ground the system to conform with all codes and ordinances.

- Install the system in a protected area. Be sure electric outlet and transformer do not come in contact with water. See Installation Considerations, in the installation section of the manual.

Do not attempt to treat water over 110°F (43°C) with the system. Always connect the system to the main water supply pipe before the water heater.

Do not expose the system to freezing temperatures. Water freezing in the system causes equipment damage.

Do not install in direct sunlight. Ultraviolet rays from the sun may cause damage.

- Minimum inlet water pressure is 30 psi. Maximum inlet water pressure is 80 psi. Use a pressure reducing valve if necessary.

**CAUTION:**

- Do not use with water that is microbiologically unsafe or of unknown quality.
- Test the water periodically to verify that the system is performing satisfactorily.
- Discard small parts remaining after the installation.

## Filter Anatomy

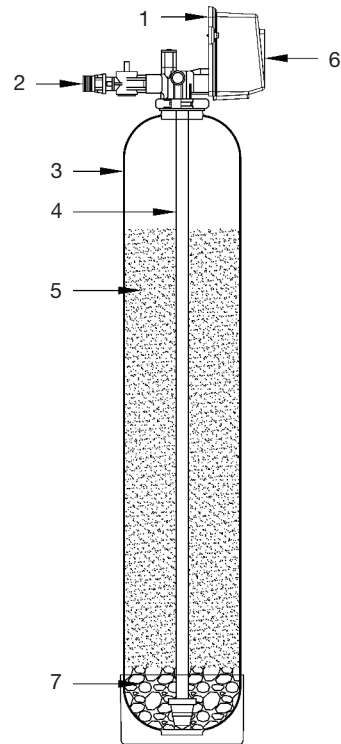

Figure 1

ITEM	DESCRIPTION
1	Control Valve
2	Bypass Valve
3	Mineral Tank
4	Distributor Tube
5	Filter Media
6	Faceplate/Control
7	Gravel Underbedding

## Specifications

MODEL	VALVE TYPE	MINERAL TANK SIZE (DXH)	MEDIA VOLUME CUBIC FOOT	GRAVEL (LBS)	PEAK SERVICE FLOW (GPM)	PRESSURE DROP @PEAK FLOW (PSI)	BACK WASH FLOW (GPM)	FLOOR SPACE REQUIRED (L X W X H)
PWBWIRONZ1	Time Clock	9" x 48"	1	12	6	<15	7	16" x 15" x 55"
PWBWIRONZ1.5	Time Clock	10" x 54"	1.5	12	8	<15	8	16" x 15" x 62"
PWBWIRONZ2	Time Clock	12" x 52"	2	25	11	<25	12	17" x 15" x 60"
PWBWIRONZ3	Time Clock	13" x 65"	3	30	13	<25	15	18" x 15" x 74"

Note: Peak service flow rate is for intermittent use only and is not to be interpreted as continuous service flow rate capability. These systems are designed to treat the domestic water used in a single family dwelling. For irrigation water treatment or higher volume applications please contact your Watts representative.

## Feed Water Parameters



**Do not use this system on water that is microbiologically unsafe or of unknown quality without adequate disinfection before or after the system!**

Minimum inlet pressure: 30 psig

Maximum operating pressure: 80 psig

Minimum water temperature: 34°F (1°C)

Maximum water temperature: 110°F (43°C)

Maximum iron content: 10 PPM

Maximum hydrogen sulfide content: 3 PPM

Effective pH range: 6.5-9

Location: Indoors (Protect from direct sunlight)

Minimum ambient temperature: 34°F (1°C)

Maximum ambient temperature: 122°F (50°C)

## Power

Voltage: 120VAC

Frequency: 60Hz

## Installation

Location: Indoors (Protect from direct sunlight)

## PWBWIRONZ System Overview

PWBWIRONZ systems are selected for use when the concentration of iron and hydrogen sulfide in water need to be reduced. They use the model 2510 AIO Control Valve to reduce the contaminants in the water without the use of chemicals. The 2510 AIO valve is specially designed to capture a volume of air inside the system's mineral tank. Water passes through the AIO valve then passes through the air head in the top of the mineral tank. Oxygen from the captured air transfers into the water. The oxygen oxidizes these contaminants in the water to oxides or solid precipitants. Then they are mechanically filtered out of the water by the Micro Z<sup>®</sup> media filter bed. After a preprogrammed number of days have passed, the system will perform a regeneration cycle to clean the Micro Z<sup>®</sup> media of the solids it has accumulated, draw in more air, rinse, then return to service. Watts recommends a daily regeneration of the system. A regeneration every other day may be possible if system inlet water quality permits (please contact your Watts representative).

### Regeneration is as follows:

Backwash (BW): The Backwash cycle washes oxidized contaminants to drain and reclassifies the media bed.

Air Draw (BD): Air Draw empties water from the tank and replenishes the oxygen within the mineral tank.

Rapid Rinse (RR): Rapid Rinse purges excess atmosphere from the mineral tank and distributor.

Upon completion of Rapid Rinse the system returns to the service position.

**NOTE: Due to the presence of air in the media tank the maximum operating pressure of the system is 80 psi.**

## II. Installation

### A. Setup

Unpack and check the system components for damaged or missing parts. Make sure that the bypass valve and plumbing yoke are properly connected to each other and to the control valve with the mounting clips. Make certain that the drain line flow control fitting is installed properly on the drain port of the control valve. Systems that are 13" in diameter and larger are not loaded with media. These systems must be loaded with media before placing into service. To load a system follow the below steps.

1. Cap the top open end of the distributor tube with tape and plastic sheeting to keep foreign debris from entering the distributor tube. This cap must be secure and not come off during media loading.
2. Place the distributor tube, screen end down, into the mineral tank and center it in the bottom. The top of the distributor tube should be flush with the top of the tank.
3. Make sure the plastic and tape cap is secure to the top of the distributor tube, place a funnel on the top of the tank and load first the gravel then the Micro Z<sup>®</sup> media into the tank. The cap must not come off of the distributor tube during the loading of the media.
4. Remove the plastic cap from the distributor tube. DO NOT PULL UP ON THE DISTRIBUTOR TUBE when removing the cap. The distributor tube top must remain flush with the top of the tank.
5. Clean any media from the threads and top of the mineral tank and install the deflector disk. See D. Deflector Installation section for more details.
6. Lubricate the O-rings on the bottom of the control valve (distributor pilot O-ring and top of tank O-ring). Use non-petroleum based silicone lubricant only.
7. Place the control valve on top of the tank. When doing this step, seat the top of the distributor tube inside the centered O-ring sealed port on the bottom of the valve first then press the valve down until the tank threads come in contact with the valve threads. This ensures that the distributor tube is properly seated into the bottom of the control valve. Thread the valve on to the tank clockwise. Be careful not to cross thread the valve or over tighten it. A hand tight snug fit is appropriate for the control valve torque. A wrench is not necessary. Do not use thread sealant or PTFE tape on the threads.
8. The system is now ready for installation.

### B. Installation Overview

Install the system after the supply lines to the outside faucets. This system should be installed before a water softener or any taste/odor cartridges, if applicable.

Ensure the inlet check valve item #5 is connected as shown in Figure 2 to the inlet side of the 2510 AIO valve. The drain should be installed in accordance with plumbing codes. Due to the release of air during regeneration, the drain line should be anchored throughout the run, secured at the end of the drain line, and properly vented. The drain line should be sized for the backwash rate listed under Drain Requirements taking into account friction loss.

### C. 2510 AIO Control Valve Component Identification:

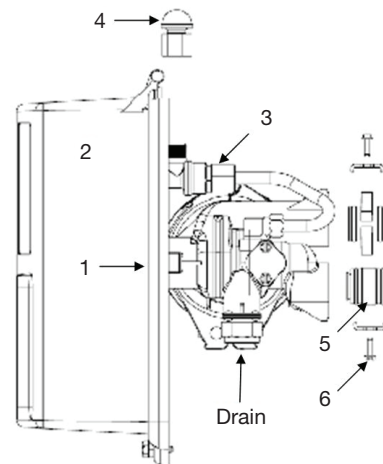

Figure 2

ITEM	DESCRIPTION
1	2510 AIO CONTROL VALVE
2	VALVE COVER
3	CHECK VALVE, AIR DRAW VALVE
4	SCREEN, AIR CHECK ADAPTOR
5	INLET CHECK VALVE
6	SCREW, 8-32, SS, 2510AIO
7	DEFLECTOR DISK

### D. Deflector Installation

Put a thin layer of silicone lubricant around inside diameter of the deflector #7. Slowly slide the deflector over the distributor tube down about 1". When threading the AIO valve to the tank, the bottom of the threads will slide the deflector down. As shown in Figure 3.

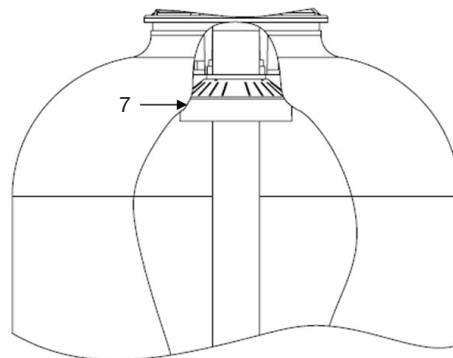

Figure 3

## E. Installation Considerations

Consider the following points when determining where to install the filter:

- Place the system as close as possible to a sewer drain.
- Do not install the filter where it would block access to the water heater, or access to the main water shutoff, water meter, or electrical panels.
- Install the filter in a place where water damage is least likely to occur if a leak develops.
- A 120VAC electrical outlet is needed to plug in the transformer.
- Always connect the system to the main water supply pipe before the water heater.
- Install the system where it will not be subject to temperatures outside of the limits stated in the Specification Section or to direct sunlight.

## F. Drain Requirements

The drain systems these filters are plumbed into must be able to accept the drain rates listed below. The well or water supply must be capable of maintaining a 30 psi minimum feed water pressure, continuously, at these drain flow rates.

MODEL	TANK SIZE	DRAIN RATE
PWBWIRONZ1	9" x 48", 1 cubic ft.	7 gpm
PWBWIRONZ1.5	10" x 54", 1.5 cubic ft.	8 gpm
PWBWIRONZ2	12" x 52", 2 cubic ft.	12 gpm
PWBWIRONZ3	13" x 65", 3 cubic ft.	15 gpm

## III. Valve Installation

1. Turn off gas or electric supply to the water heater.
2. Close the feed water valve to the plumbing system. Then relieve the pressure in the plumbing by opening the hot and cold water faucets.
3. Cut the pipes at the installation point. Use a drain pan to catch any spillage that results.
4. Move the filter system into installation position.
  - Be sure the installation point is downstream of the bladder tank and irrigation system if this system is being installed on a well.
  - The installation surface must be strong enough to support the weight of the system once it is placed into operation.
5. Plumb INLET and OUTLET connections to and from the filter.
  - Be sure the incoming water supply is directed to the INLET port of the valve.
  - The valve body of the control is marked with arrows indicating the proper flow direction.
  - Connections are illustrated below in Figure 4 (shown without bypass and yoke) and Figure 5 (bypass piping detail).

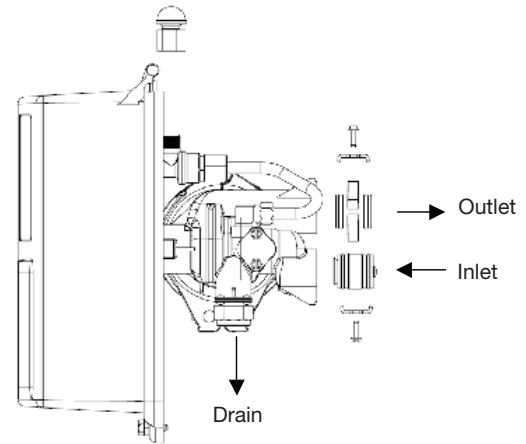

Figure 4

6. Connect and route the valve drain line using rigid piping or hose. Use the same size plumbing for the drain line as the fitting provided for the drain connection. The smallest units have a 1/2" connection, the medium sized units have a 3/4" connection, and the largest units have a 1" connection. It is important to use the same size plumbing as the connection to ensure proper backwash flow.

**Note:** Leave an air gap of at least 1 1/2" between the end of the drain plumbing and the drain point.

**CAUTION:** If making a soldered copper installation, do all sweat soldering before connecting pipes to the bypass valve. Torch heat will damage plastic parts.

**CAUTION:** When turning threaded pipe fittings onto plastic fittings, use care not to cross-thread or overtighten.

**CAUTION:** Use PTFE tape on all external pipe threads. Do not use pipe joint compound.

**CAUTION:** Support inlet and outlet plumbing in some manner (use pipe hangers) to keep the weight off of the control valve drain, bypass, and plumbing yoke points of connection.

### III. Installation (cont.)

- Place the bypass valves into the "bypass" position as shown below in Figure 5 by rotating the bypass handles. The handles will point to each other when they are placed into the bypass position.

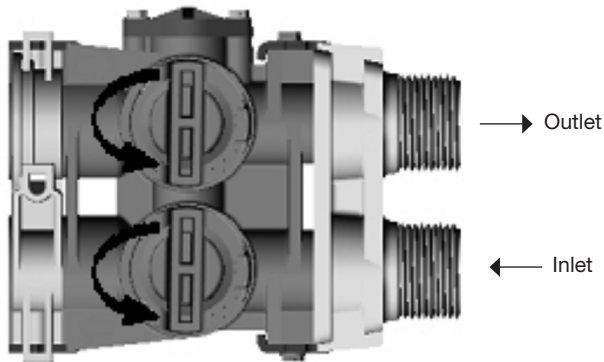
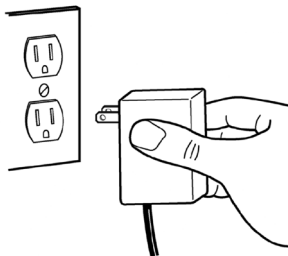
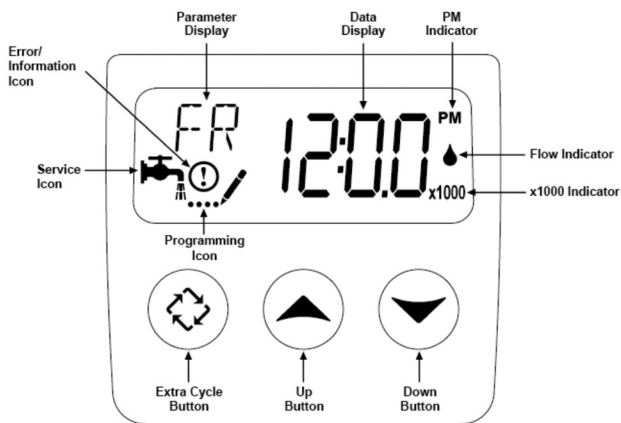

Figure 5

- Fully open two (2) cold water faucets near the water filter.
- Fully open the main feed water valve described in step 2. Observe a steady flow from both faucets.
- Close all faucets at this time.
- Check plumbing work for leaks and fix immediately if any are found.
- Connect electrical power by plugging the transformer into a (120 VAC) outlet.



- Open the valve cover to access the timer. Press and hold the "Extra Cycle" button until the flashing "BW" symbol appears in the Parameter Display.



- Slowly, turn the bypass valve back to the "service" position. In the service position both handles of the bypass valve will point to the control valve. Then close the inlet bypass valve.
- Unplug the valve when the "BW" symbol stops flashing and the countdown timer appears. This keeps the valve in an extended backwash for the initial startup.

- Open the outlet bypass valve fully.
- Open the inlet bypass valve slightly. Open the valve just until you hear water flowing.
- Observe the drain flow. It may take several minutes for the filter vessel to fill up with water and begin to flow water to drain.
- After all the air is purged from the vessel and a steady drain flow is observed, allow the unit to backwash for 10 minutes with the inlet valve open slightly.
- After the 10 minutes of backwashing is complete, fully open the inlet bypass valve and allow the unit to backwash for 90 minutes.
- After 90 minutes, observe the drain flow. If the drain flow is clear proceed to the next step. If the drain flow is still cloudy, allow the system to continue to backwash until it is clear. Do not capture the drain water in a container to evaluate its clarity. Oxidized impurities in the water will give the drain water a cloudy appearance if it is caught and viewed in volume. Evaluate its clarity as it flows out of the open end of the drain pipe or hose to avoid unnecessary backwashing time.
- Plug the unit back in to the electrical outlet and allow it to finish backwash, draw, and rinse cycles. This will take approximately 60 minutes.
- Set the time of day. Press and hold either the Up or Down buttons until the programming icon replaces the service icon and the parameter display reads TD. Adjust the displayed time with the Up and Down buttons. When the desired time is set, press the Extra Cycle button to resume normal operation. The unit will also return to normal operation after 5 seconds if no buttons are pressed.
- Turn on the gas or electric supply to the water heater after all air has been purged from the house's plumbing system and water heaters. Flush water heaters and plumbing system with filtered water to help clear the lines of any residual iron content.

The system is now ready to be programmed.

## IV. Programming

Figure 6 shows the icons and display characters of the timer mechanism.

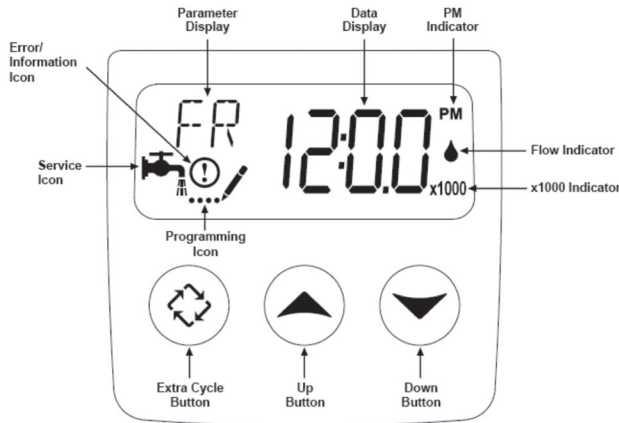

Figure 6

When the Master Programming Mode is entered, all available option/setting/displays may be viewed and set as needed. Depending on current option settings, some parameters cannot be viewed or set. This timer is used on other system configurations as well so it is important that the user carefully programs the system in accordance with the values shown on the Master Programming Chart.

### A. Setting the Time of Day

1. Press and hold either the Up or Down buttons until the programming icon replaces the service icon and the parameter display reads TD.
2. Adjust the displayed time with the Up and Down buttons.
3. When the desired time is set, press the Extra Cycle button to resume normal operation. The unit will also return to normal operation after 5 seconds if no buttons are pressed.



### B. Entering Master Programming Mode

The master level programming has been set at the factory however you should check the program against the Master Programming Chart. With the control valve in the service position set the Time Of Day display to 12:01 P.M. Press the Extra Cycle button (to exit Setting Time of Day mode). Then press and hold the Up and Down buttons together until the programming icon replaces the service icon and the Display Format "DF" screen appears. Once you are in the master programming screen, pressing the extra cycle button will advance the controller to the next parameter. Pressing the up or down buttons allows the user adjust each parameter's value up or down respectively.

### C. Exiting Master Programming Mode

Press the Extra Cycle button to accept the displayed settings and advance to the next parameter. Press the Extra Cycle button at the last parameter to save all settings and return to normal operation. The control will automatically disregard any programming changes and return to normal operation if it is left in Master Programming mode for 5 minutes without any keypad input.

## D. Master Programming Chart

PROGRAMMING ABBREVIATION	PROGRAMMING DEFINITION	*OPTION ABBREVIATION	OPTION DEFINITION
DF	Display Format	GAL	Gallons - 12 hour time
VT	Valve Type	DF 1b	Downflow Single Backwash
CT	Control Type	tc	Time Clock - Regenerates based on days
NT	Number of Tanks	1	Single Tank
DO	Day Override	1	Days Between Regeneration – DO NOT set the regeneration day override for a longer period than two days, as the filter media can become fouled with contaminates, rendering the system ineffective.
RT	Regeneration Time	12:30 AM	Regeneration Time – Time of day regeneration is to occur. Make sure this time does not overlap with the regeneration process of another piece of equipment such as an existing softener or media filter.
BW	Backwash	14	See Page 3 for Definition
BD	Air Draw	40	See Page 3 for Definition
RR	Rapid Rinse	1	See Page 3 for Definition
BF	Brine Fill	Off	Not Applicable

\*Factory Default Values

## V. Controller Operation

The factory default program settings should be adequate for most installations.

### A. Queuing a Regeneration

1. Press the Extra Cycle button. The service icon will flash to indicate that a regeneration is queued. Regeneration will occur that day at the programmed Regeneration Time (RT).
2. To cancel a queued regeneration, press the Extra Cycle button.

### B. Regenerating Immediately

Press and hold the Extra Cycle button for five seconds.

#### Time Clock Delayed Control

A Time Clock Delayed Control regenerates the system on a timed interval. The control will initiate a regeneration cycle at the programmed regeneration time when the number of days since the last regeneration equals the regeneration day override value.

#### Control Operation During Regeneration

During regeneration, the control displays a special regeneration display. In this display, the control shows the current regeneration step number, the valve it is advancing to, or has reached, and the time remaining in that step. The step number that displays flashes until the valve completes driving to this regeneration step position. Once all regeneration steps are completed the valve returns to service and resumes normal operation.

Pressing the Extra Cycle button during a regeneration cycle immediately advances the valve to the next cycle step position and resumes normal step timing.

#### Control Operation During Programming

The control only enters the Program Mode with the valve in service. While in the Program Mode, the control continues to operate normally monitoring water usage and keeping all displays up to date. Control programming is stored in memory permanently, eliminating the need for battery backup power.

## V. Controller Operation (cont.)

### C. Control Operation During A Power Failure

The controller includes integral power backup. In the event of a power failure, the control shifts into a power-saving mode. The display and motor shut down, but it continues to keep track of the time and day for a minimum of 48 hours.

The system configuration settings are stored in a non-volatile memory and are stored indefinitely with or without line power. The Time of Day flashes when there has been a power failure. Press any button to stop the Time of Day from flashing.

If power fails while the unit is in regeneration, the control will save the current valve position before it shuts down. When power is restored, the control will resume the regeneration cycle from the point where power failed. Note that if power fails during a regeneration cycle, the valve will remain in its current position until power is restored. System installation should include all required safety components to prevent overflows resulting from a power failure during regeneration.

The control will not start a new regeneration cycle without line power. If the valve misses a scheduled regeneration due to a power failure, it will queue a regeneration. Once power is restored, the control will initiate a regeneration cycle the next time that the Time of Day equals the programmed regeneration time. Typically, this means that the valve will regenerate one day after it was originally scheduled.

### Troubleshooting

PROBLEM	CAUSE	SOLUTION
1. Loss of Water Pressure	Sediment buildup in filter bed	A. Perform a manual backwash B. Make sure unit is plugged in C. Replace media bed
2. Drain Flows Continuously	Foreign material in control	Remove piston assembly and inspect bore, remove foreign material & check control in various ports
3. Wrong time of day	Power Outage	Reset time of day, be sure power supply is uninterrupted
4. Controller Cycles Continuously	Faulty timer board or microswitch	A. Perform a manual regeneration to clear issue B. Check programming for accuracy C. Make sure all wire connections are secure
5. Unfiltered water in house	A. Bypass in bypass position B. Valve stalled in backwash C. No air in tank D. Media is fouled E. No power to valve F. System is plumbed in backwards G. System needs to be regenerated more frequently	A. Move bypass to service position B. Have valve serviced C. Have valve serviced D. Have media replaced E. Restore power to valve F. Correct plumbing G. Increase regeneration frequency
6. System fails to regenerate	A. Electrical service to unit has been interrupted B. Timer is defective C. Power failure	A. Ensure permanent electrical service (check fuse, plug, GFCI) B. Replace timer C. Reset time of day

#### Error Codes

Note: Error codes appear in the service display.

ERROR CODE	CAUSE	SOLUTION
(Err 0)	Drive motor is stalled	See above troubleshooting table, #5-B
(Err 1)	Drive motor runs continuously	See above troubleshooting table, #4
(Err 2)	There has been more than 99 days since the last regeneration	Initiate a manual regeneration. Verify that all master programming in the timer matches the master programming chart.
(Err 3)	Control Board memory failure	Replace control board

#### CALIFORNIA PROPOSITION 65 WARNING

Warning: This product contains chemicals known to the State of California to cause cancer and birth defects or other reproductive harm. (California law requires this warning to be given to customers in the State of California).

**For more information: [www.watts.com/prop65](http://www.watts.com/prop65)**

**LIMITED WARRANTY:** Certain Watts Pure Water products come with a limited warranty from Watts Regulator Co. Other products may have no warranty or are covered by the original manufacturer's warranty only. For specific product warranty information, please visit [www.watts.com](http://www.watts.com) or the published literature that comes with your product. Any remedies stated in such warranties are exclusive and are the only remedies for breach of warranty. **EXCEPT FOR THE APPLICABLE PRODUCT WARRANTY, IF ANY, WATTS MAKES NO OTHER WARRANTIES, EXPRESS OR IMPLIED. TO THE FULLEST EXTENT PERMITTED BY APPLICABLE LAW, WATTS HEREBY SPECIFICALLY DISCLAIMS ALL OTHER WARRANTIES, EXPRESS OR IMPLIED, INCLUDING BUT NOT LIMITED TO THE IMPLIED WARRANTIES OF MERCHANTABILITY AND FITNESS FOR A PARTICULAR PURPOSE, AND IN NO EVENT SHALL WATTS BE LIABLE, IN CONTRACT, TORT, STRICT LIABILITY OR UNDER ANY OTHER LEGAL THEORY, FOR INCIDENTAL, INDIRECT, SPECIAL OR CONSEQUENTIAL DAMAGES, INCLUDING, WITHOUT LIMITATION, LOST PROFITS OR PROPERTY DAMAGE, REGARDLESS OF WHETHER IT WAS INFORMED ABOUT THE POSSIBILITY OF SUCH DAMAGES.**



A Watts Water Technologies Company

USA: Tel. (800) 224-1299 • [www.watts.com](http://www.watts.com)

Canada: Tel. (888) 208-8927 • [www.watts.ca](http://www.watts.ca)