

Please Read Prior to Installation:

1. Before installing any Ames assembly, **FLUSH THE LINE THOROUGHLY** to remove all debris, chips and other foreign objects. Failure to do so may make the assembly inoperable.
2. The Ames 4001SS and 5001SS Reduced Pressure Backflow Preventers may be installed in horizontal or vertical positions as shown below. **LOCAL WATER AUTHORITIES MUST APPROVE ALL INSTALLATION CONFIGURATIONS.**
3. **Backflow preventers must be installed in high-visibility locations in order to allow for immediate notice of telltale discharge or other malfunction. This location should also facilitate testing and servicing and protect against freezing and vandalism.**
4. Installing a backflow preventer in a pit or vault is not recommended. Ensure that all local codes and required safety provisions are met. An air gap below the relief port must be maintained so as to avoid flooding and submersion of the assembly, which may lead to a cross connection. Ames recommends installations indoors or above ground in an insulated enclosure. Normal discharge and nuisance spitting are accommodated by the use of an Ames air gap fitting and a fabricated indirect waste line. Adequate floor drain **MUST** be provided in case of excessive discharge.
5. **IF INSTALLING ON FIRE PROTECTION SYSTEM, BE SURE TO PURGE AIR FROM FIRE SYSTEM.**
Fill system slowly with all inspector's test valves open. Additional venting of air may be required.
6. The flange gasket bolts for the gate valves shall be retightened during installation as the bolts may have loosened due to shipping.

AMES^{CO.}
FLUID CONTROL SYSTEMS

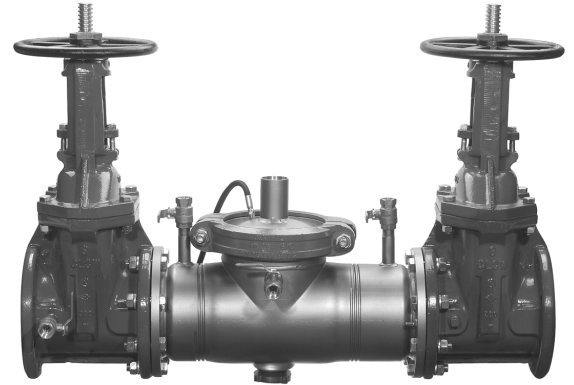

**Ames Model
4001SS and 5001SS
Reduced Pressure Backflow Preventer
General Installation, Maintenance,
and Parts Information 3" - 6"**

INDOOR INSTALLATION

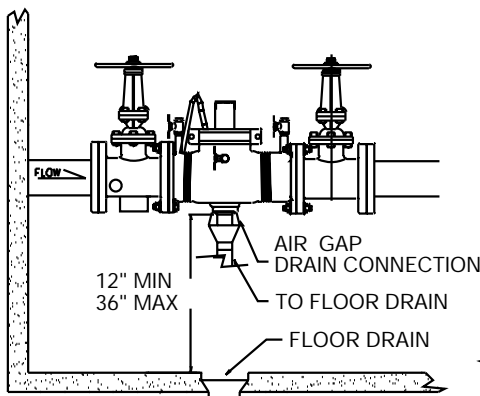

HORIZONTAL INSTALLATION

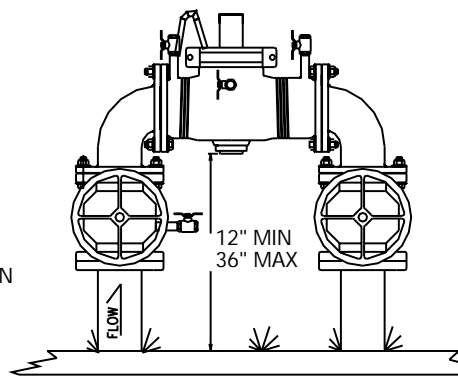

OUTDOOR INSTALLATION

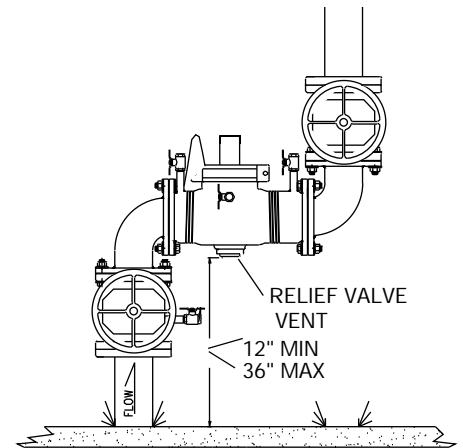

REMOVING CAM-CHECKS

Place yourself so that the water flow through the valve is left to right.

1. Shut down water system and lock out system if possible. Slowly open all ball valves to relieve air and water pressure. After pressure is relieved, loosen bolts on groove coupler and remove groove coupler and cover plate from valve body.
2. Remove #1 Cam-check Assembly. **Do not use Cam Arm as a handle to unscrew Cam-Check.** Insert lid bolts in 1st check seat ring (see fig. 1), insert a long screwdriver or pry bar between lid bolts. Gently apply pressure against the bolts and turn seat assembly counter clockwise moving bolts hole to hole to maintain turning leverage (two additional bolts will eliminate need to move lid bolts from hole to hole). Finish unscrewing by hand and remove through top access port. Unscrew #2 Cam-Check (turn counter-clock wise) by placing a long screwdriver across lid bolts inserted in holes located in the 2nd check seat ring, similar in method used to remove 1st check and applying pressure to loosen #2 Cam-Check. Finish unscrewing by hand.
3. To clean Cam-Check, locate the Cam Arm opening stud on the outlet flange of the valve assembly. Slide the Cam Arm over the stud with the check threads facing downward (fig. 2). Tighten a 1/4" nut on stud to secure cam bar. Slowly pull the assembly outward to open check allowing exposure of the seat and clapper contact area for cleaning. The assembly may be locked open by aligning the holes in the cam bar and hinge arms and inserting a rod (fig. 4).

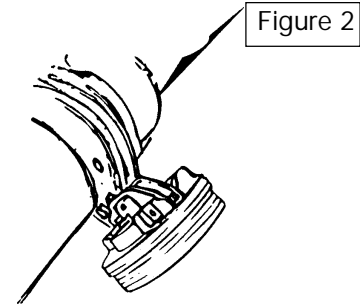
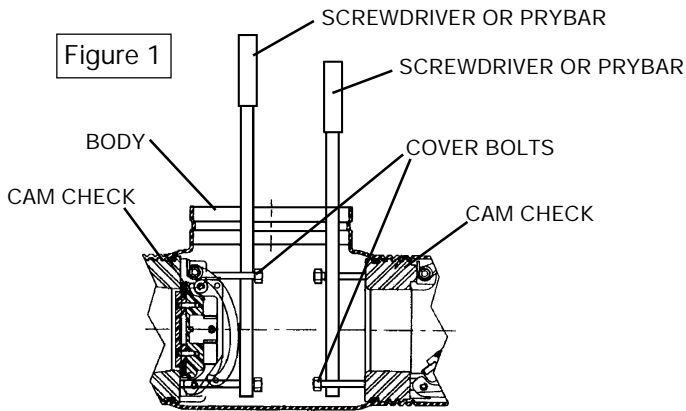

3", 4" & 6" RP 1st Cam-Check

CAM-CHECK DISASSEMBLY

Please use caution when disassembling cam-check.

The cam-check is a spring-loaded mechanical device. Failure to do so may result in potential injury.

FIGURE 3

Press down on the check assembly to unload the cambar from hinge arms and roller. Then place a thin rod into a maintenance hole in one hinge arm.

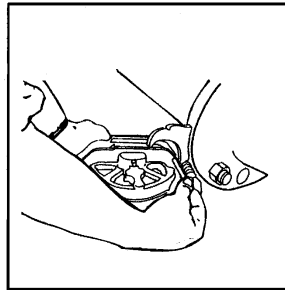

FIGURE 4

Using your free hand, swing the clapper assembly away from the seat. Align (A) lockout holes.

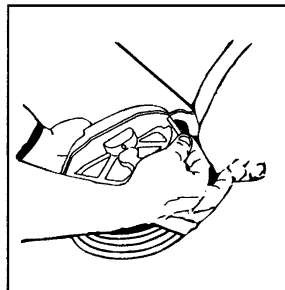

FIGURE 5

Remove 1 c-clip from the center pivot pin. Withdraw the center pivot pin from the clapper and the hinge arms. Remove the clapper assembly from the check assembly module. **Note:** You may replace this item as an assembly or you may continue and replace only the sealing disc.

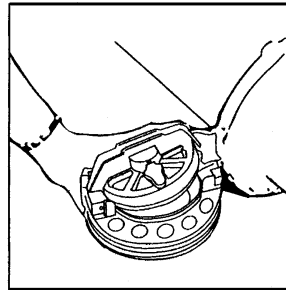
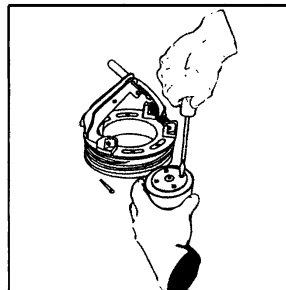

FIGURE 6

Disassemble the clapper by removing 4 screws, disc retainer and the clapper disc. Disc may be flipped if sealing surface is damaged.



Before reinstallation of check assembly, thoroughly clean O-ring groove and lubricate O-ring with F.D.A. approved lubricant.

5001SS: Contact factory for bypass component servicing information.

Air Gap Drain: Contact factory for additional information.

Figure 7

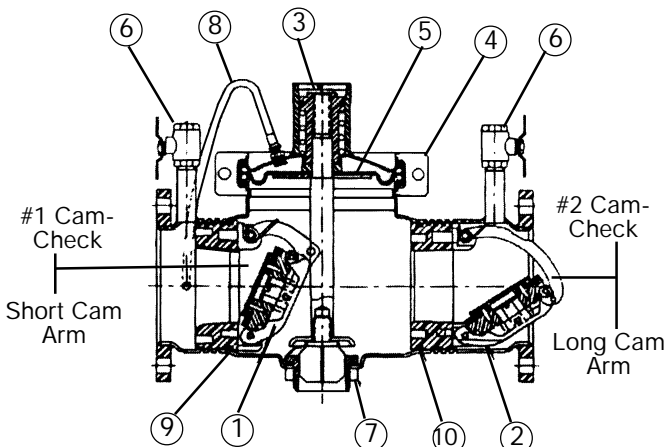

DETAILED PARTS LISTING - PARTS TABLE #1 (Figure 7)

Item #	Part Description	Qty	3"	4"	6"
1.	#1 Cam-Check	1	116-04200	116-04200	116-06200
2.	#2 Cam-Check	1	116-04101	116-04101	116-06101
3.	Relief Valve Assembly Cover Plate Diaphragm Relief Valve Internals	1	116-04020	116-04020	116-06020
4.	Groove Coupler	1	6-05028	6-05028	6-05128
5.	Diaphragm / Gasket	1	16-00067	16-00067	16-00075
6.	Ball Valve	3	980-00527	980-00527	980-00449
7.	Relief Valve Seat Assy.	1	116-04022	116-04022	116-04022
8.	Relief Valve Sensing Line	1	16-00079	16-00079	16-06079
9.	1st Cam Check O-ring	1	6-05064	6-05064	6-05142
10.	2nd Cam Check O-ring	1	6-05021	6-05021	6-05121
11.	Shutoff valves (not shown)				

CAM-CHECK- PARTS TABLE #2 (Figure 8)

Item #	Part Description	Qty.	3"	4"	6"
1.	1st Cam-Check O-ring (removable)*	1	6-05064	6-05064	6-05142
2.	Clapper Assembly (removable)	1	116-04026	116-04026	116-06026
3.	Clapper Retaining Plate Screws (removable)	4	16-00080	16-00080	16-00084
4.	Clapper Retainer Plate (removable)	1	16-00017	16-00017	16-00018
5.	Clapper Disc (removable)*	1	16-00019	16-00019	16-00020
6.	Pivot Arm Pin (removable) 2 c-clips*	1	16-00041	16-00041	16-00025
7.	2nd Cam-Check O-ring (removable)*	1	6-05021	6-05021	6-05121
8.	1st Cam-Check Rubber Kit (consists of * items)	1	116-04032	116-04032	116-06032
9.	2nd Cam-Check Rubber Kit (Consists of * items)	1	116-04033	116-04033	116-06032
10.	C-Clips Kit	1	116-04034	116--04034	116-06033

Figure 8

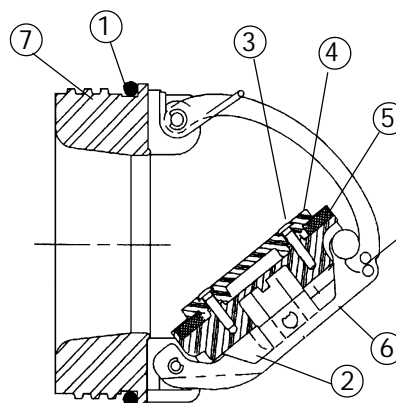

Note: Align holes and insert pin or small screwdriver to hold in open position.

SERVICING THE RELIEF VALVE

Figure 9

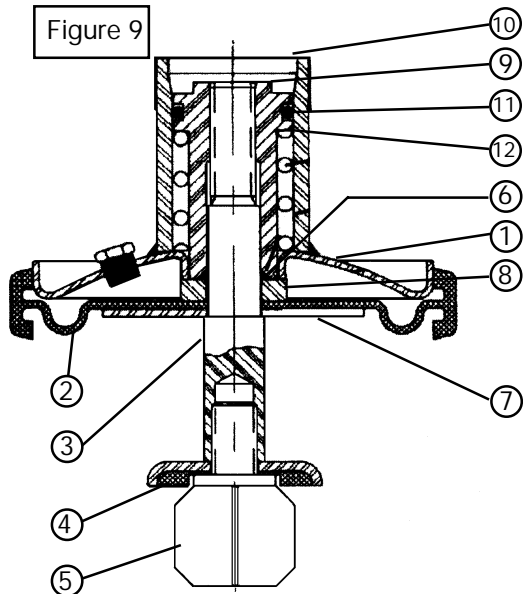

PARTS TABLE #3 (Figure 9)

Item #	Part Description	Qty	3"	4"	6"
1.	Cover	1	116-04023	116-04023	116-06023
2.	Diaphragm/Gasket*	1	16-00067	16-00067	16-00075
3.	Shaft	1	16-00063	16-00063	16-00073
4.	Sealing Disc*	1	16-00054	16-00054	16-00054
5.	Guide, Lower	1	16-00055	16-00055	16-00055
6.	O-Ring*	1	5-06090	15-06090	5-06090
7.	Support Disc	1	16-00059	16-00059	16-00072
8.	Disc, Diaphragm Stop	1	16-00058	16-00058	16-00074
9.	Guide, Upper	1	16-00061	16-00061	16-00061
10.	Cover, Dust	1	980-00721	980-00721	980-00721
11.	O-Ring, Upper*	1	5-06089	5-06089	5-06089
12.	Spring	1	16-00099	16-00099	16-00066
13.	Relief Valve Rubber Kit (consists of * items)	1	116-04031	116-04031	116-06031

RELIEF VALVE SERVICE INSTRUCTIONS

1. Prior to beginning any maintenance work, shut down the water supply to the unit.
2. The relief valve is an integral part of the lid assembly and may be serviced when the lid assembly is removed from the body of the valve.
3. The relief valve may be disconnected from the sensing line hose if desired to enable easier access to all parts of the assembly.

REPLACING THE SEALING DISC.

1. Unscrew the lower guide, (5) from the shaft (3).
2. Replace the sealing disc assembly (4).
3. Screw the lower guide (5) back into the shaft (3). The lower guide will seal the assembly with pressure against the elastomer in the sealing disc assembly (4).

COMPLETE DISASSEMBLY OF THE RELIEF VALVE.

1. Remove the sealing disc as above.
2. Remove the dust cover (10) from the cover weldment (1)
3. Unload the internal spring by unscrewing the guide, shaft (9) using a socket wrench.
4. Draw the shaft out through the bottom of the diaphragm.
5. Remove the spring through the top of the cover weldment
6. Remove guide O-ring (6)
7. Remove O-ring (12) from the guide shaft.

REASSEMBLY

1. Replace all O-rings
2. Reverse disassembly steps above.

TROUBLE SHOOTING GUIDE - 4001SS and 5001SS

PROBLEM	CAUSE	SOLUTION
A. Assembly discharges from differential relief valve during no flow condition.	Fouled first check Fluctuating inlet pressure Outlet pressure higher than inlet pressure & leak in No. 2 check valve Leak through diaphragm Pressure relief valve does not close	Disassemble and clean No. 1 check valve Control supply line water pressure Disassemble, clean #2 check valve & identify cause of back pressure Service relief valve (page 3) See problem D
B. Assembly discharges from differential relief valve during a flow condition.	Pressure relief valve does not close	See problem D
C. Differential pressure relief valve does not open during test	Differential pressure across No. 1 check valve stays above 2.0 PSI due to leaking outlet gate valve Weak or broken relief valve spring Winged retainer bound in body Plugged hydraulic hose	Repair shut-off valves Disassemble and replace relief valve spring Disassemble and repair Disassemble and repair
D. Pressure relief valve does not close	Debris on sealing surface Plugged hydraulic hose Damaged seat or rubber shut off disc Ruptured diaphragm	Remove relief valve and clean Disassemble and clean Remove relief valve assembly and replace Disassemble and replace diaphragm

PROBLEM IDENTIFICATION PROCEDURES - MODEL 4001SS and 5001SS

1. When using differential pressure gauge.

A. Check differential across No. 1 check valve

READING	PROBLEM
2 to 3 PSID check	Leak in No. 1 or No. 2 valve
4 to 7 PSID and steady	Malfunctioning pressure relief valve
2 to 7 PSID fluctuating	Inlet pressure fluctuating

2. Without using differential pressure gauge.

A. Close gate valve No. 2

RESULT	PROBLEM
If discharge stops	Leak in No. 2 check valve
If discharge does not stop	Go to B
B. Open No. 4 test cock to produce a flow greater than differential relief valve discharge	
RESULT	PROBLEM
If discharge stops	Leak in No. 1 check valve
If discharge does not stop	Malfunctioning pressure relief valve

LIMITED WARRANTY (Full description of limited warranty is found in Ames Product catalogue.)

This Ames warranty is expressly in lieu of any other warranties, expressed or implied, including without limitation, warranties of MERCHANTABILITY AND FITNESS FOR A PARTICULAR PURPOSE. Ames shall not be responsible for any incidental or consequential damages including without limitation, damages or other costs resulting from labor charges, delays, vandalism, negligence, fouling caused by foreign material, damage from adverse water conditions, chemicals, or any other circumstances over which Ames has no control.

No statement, representation, agreement or understanding, oral or written, made by agent, by an authorized Ames dealer, an Ames representative or employee which is not contained in this limited warranty will be recognized or enforceable or binding upon Ames Company, Inc. Only a written statement signed by an officer of Ames may modify this limited warranty.

Any action for breach of any Ames Warranty must be commenced within one (1) year after date on which cause of action occurred.

CALIFORNIA PROPOSITION 65 WARNING

WARNING: This product contains chemicals known to the State of California to cause cancer and birth defects or other reproductive harm. (Installer: California law requires that this warning be given to the consumer.)

For more information: www.wattsind.com/prop65



FLUID CONTROL SYSTEMS

Ames Company Inc.
 1485 Tanforan Ave.
 Woodland, CA 95776
 (530) 666-2493
 Fax (530) 666-5320

A DIVISION OF WATTS INDUSTRIES