



# BASIC VALVES 605GD-16 (Globe) 605AD-16 (Angle)

0106

## Standard Materials

Body & Cover: Ductile Iron ASTM A536

Coating: NSF Listed Fusion Bonded Epoxy Lined and Coated

Trim: 316 Stainless Steel

Elastomers: Buna-N (standard)  
EPDM  
Viton

Stem, Nut & Spring: Stainless Steel

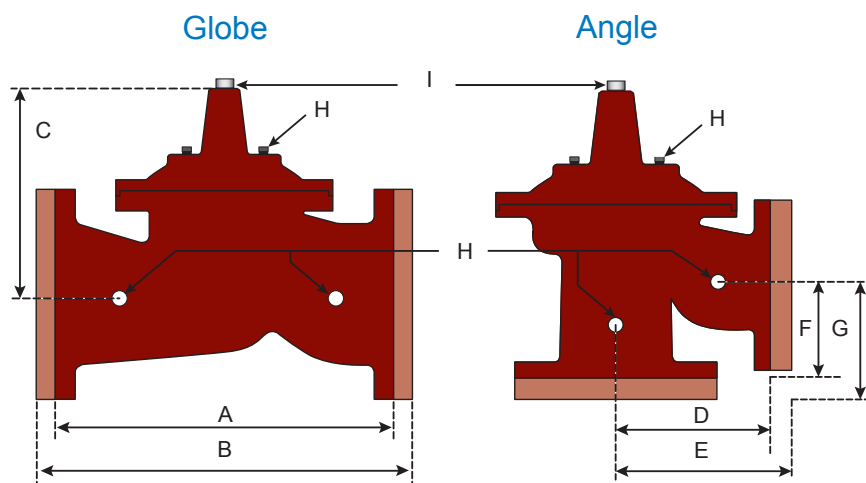

## Dimensions

	A	B	C	D	E	F	G	H	I	
VALVE SIZE	GLOBE 150#	GLOBE 300#	COVER TO CENTER	ANGLE 150#	ANGLE 300#	ANGLE 150#	ANGLE 300#	PORT SIZE	PORT SIZE	SHIPPING WEIGHTS*
4	13-7/8	14-1/2	8-5/8	6-15/16	7-1/4	5-1/2	5-13/16	1/2	1/2	39
6	17-3/4	18-5/8	11-5/8	8-7/8	9-3/8	6-3/4	7-1/4	3/4	3/4	89
8	21-3/8	22-3/8	15	10-11/16	11-3/16	7-1/4	7-3/4	3/4	3/4	150
10	26	27-3/8	17-7/8					1	1	283
12	30	31-1/2	21					1	1	408
16	35	36-5/8	25-3/4					1	1-1/4	626
18	48	49-5/8	31					1	2	1145
20	48	49-5/8	31					1	2	1170
24	48	49-3/4	31					1	2	1265

\*Estimated in lbs.

## Description

The Ames Models 605GD-16 and 605AD-16 are reduced port, single chamber basic valves that incorporate a two-piece disc and diaphragm assembly. This assembly is the only moving part within the valve allowing it to open, close, or modulate as commanded by the pilot control system. The lower portion of this two-piece assembly is a mechanical check feature, which acts independent of diaphragm position or pilot control system, and provides immediate check action when flow ceases. The reduced port design offers improved low-flow performance and cavitation resistance.

Model 605GD-16: Globe Pattern Single Chamber Basic Valve with Mechanical Check Feature

Model 605AD-16: Angle Pattern Single Chamber Basic Valve with Mechanical Check Feature

## Operating Pressure

150 Flanged = 250 psi / 300 Flanged = 400 psi

## Operating Temperature

Buna-N: 160°F Maximum

EPDM: 300°F Maximum

Viton: 250°F Maximum

## Flow Data - 605GD-16 (Globe) / 605AD-16 (Angle)

Valve Size - Inches	4	6	8	10	12	16	18	20	24
Maximum Continuous Flow Rate Gpm (Water)	485	800	1850	3100	5000	7000	11100	11100	11100
Maximum Intermittent Flow Rate Gpm (Water)	590	1000	2300	4000	6250	8900	14100	14100	14100
CV Factor GPM (Globe)	133	224	489	932	1428	2067	2881	2881	2881
CV Factor GPM (Angle)	132	237	534						

Estimated

Maximum continuous flow based on velocity of 20 ft. per second.

Maximum intermittent flow based on velocity of 25 ft. per second.

The C<sub>v</sub> Factor of a valve is the flow rate in US GPM at 60° F that will cause a 1 psi drop in pressure.

The factors stated are based upon a fully open valve.

Cv factor can be used in the following equations to determine Flow (Q) and Pressure Drop (Δ P):

$$Q (\text{Flow}) = C_v \sqrt{\Delta P} \quad \Delta P (\text{Pressure Drop}) = (Q/C_v)^2$$

### Headloss

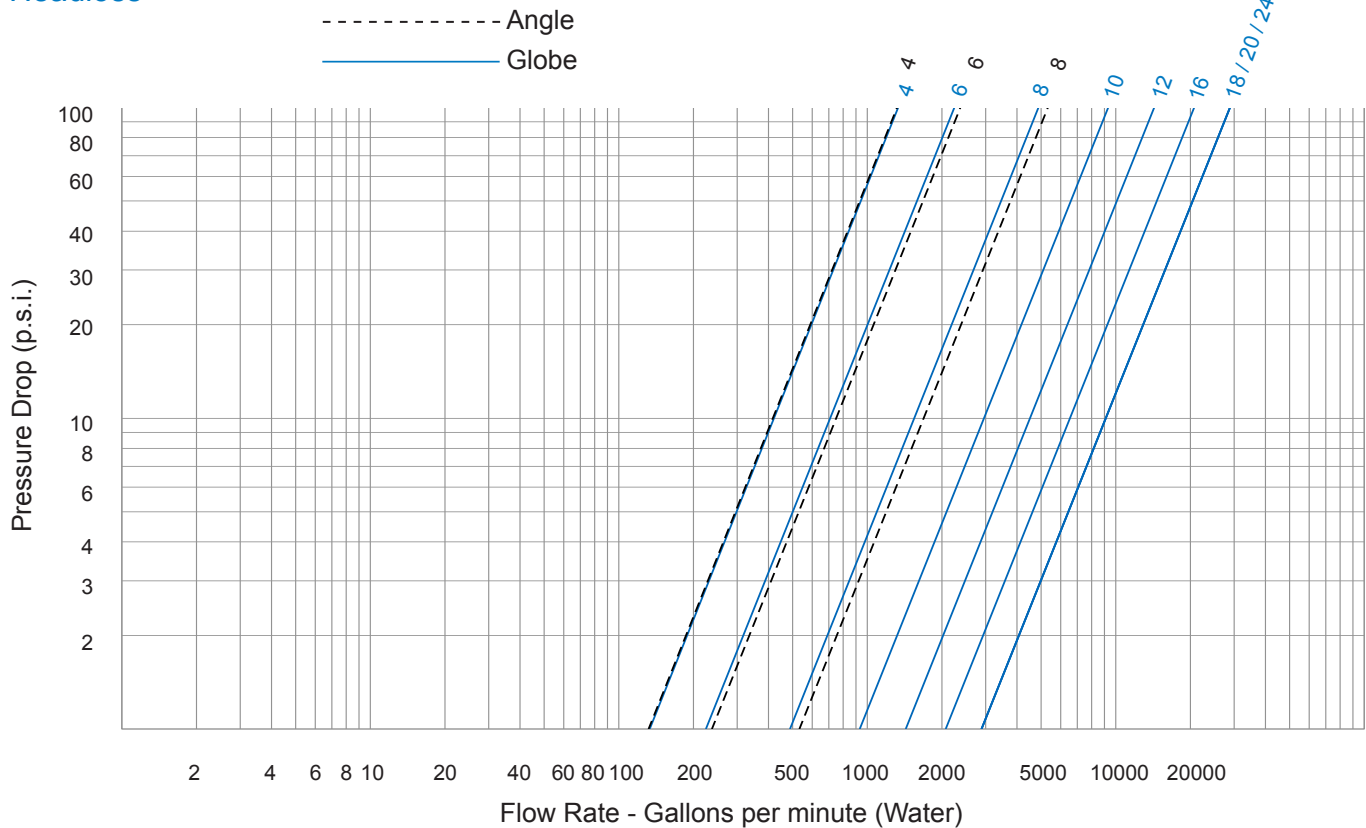

### Valve Cover Chamber Capacity

Valve Size (in)	4	6	8	10	12	16	18	20	24
fl.oz.	10	22	70						
U.S. Gal				1-1/4	2-1/2	4	9-1/2	9-1/2	9-1/2

### Valve Travel

Valve Size (in)	4	6	8	10	12	16	18	20	24
(in)	3/4	1	1-1/2	2	2-1/2	3	4	4	4