

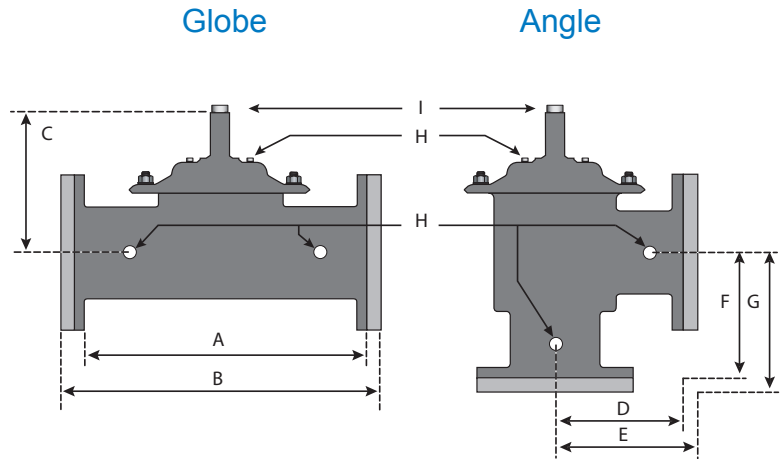

Standard Materials

- Body & Cover: 304L Stainless Steel (standard)
316L Stainless Steel
- Flanges: Class D Zinc Plated Steel with Stainless Steel Seal Welds (standard)
304L Stainless Steel (-09 Option)
- Trim: 316 Stainless Steel
- Elastomers: Buna-N (standard)
EPDM
Viton
- Stem, Nut & Spring: Stainless Steel



Dimensions

	A	B	C	D	E	F	G	H	I	
VALVE SIZE	GLOBE 150#	GLOBE 300#	COVER TO CENTER	ANGLE 150#	ANGLE 300#	ANGLE 150#	ANGLE 300#	PORT SIZE	PORT SIZE	SHIPPING WEIGHTS*
6	17-3/4	18-5/8	11-5/8	8-7/8	9-3/8	6-3/4	7-1/4	3/4	3/4	77
8	21-3/8	22-3/8	15	10-11/16	11-3/16	7-1/4	7-3/4	1	3/4	168
10	26	27-3/8	17-7/8					1	1	225
12	30	31-1/2	21					1	1-1/4	376
16	35	36-5/8	25-3/4					1	1-1/4	450
18	48	49-5/8	31					1	1-1/2	850
20	48	49-5/8	31					1	1-1/2	860
24	48	49-3/4	31					1	1-1/2	870

*Estimated in lbs.

Description

The AMES Models 605GS-16 and 605AS-16 are reduced port, single chamber basic valves that incorporate a two-piece disc and diaphragm assembly. This assembly is the only moving part within the valve allowing it to open, close, or modulate as commanded by the pilot control system. The lower portion of this two-piece assembly is a mechanical check feature, which acts independent of diaphragm position or pilot control system, and provides immediate check action when flow ceases. The reduced port design offers improved low-flow performance and cavitation resistance.

The Stainless Steel design offers superior corrosion resistance, as well as a lightweight alternative to conventional heavy iron valves. Stainless Steel construction provides extended diaphragm life, and reduces the frequency and labor costs associated with traditional maintenance repairs.

Model 605GS-16: Globe Pattern Single Chamber Basic Valve with Mechanical Check Feature

Model 605AS-16: Angle Pattern Single Chamber Basic Valve with Mechanical Check Feature

Operating Pressure

150 Flanged = 250 psi / 300 Flanged = 400 psi

Operating Temperature

Buna-N: 160°F Maximum

EPDM: 300°F Maximum

Viton: 250°F Maximum

Flow Data - 605GS-16 (Globe) / 605AS-16 (Angle)

Valve Size - Inches	6	8	10	12	16	18	20	24
Maximum Continuous Flow Rate Gpm (Water)	800	1850	3100	5000	7000	11100	11100	11100
Maximum Intermittent Flow Rate Gpm (Water)	1000	2300	4000	6250	8900	14100	14100	14100
C _v Factor GPM (Globe)	224	489	932	1428	2067	2881	2881	2881
C _v Factor GPM (Angle)	237	534						

Estimated

Maximum continuous flow based on velocity of 20 ft. per second.

Maximum intermittent flow based on velocity of 25 ft. per second.

The C_v Factor of a valve is the flow rate in US GPM at 60° F that will cause a 1 psi drop in pressure.

The factors stated are based upon a fully open valve.

C_v factor can be used in the following equations to determine Flow (Q) and Pressure Drop (Δ P):

$$Q (\text{Flow}) = C_v \sqrt{\Delta P} \quad \Delta P (\text{Pressure Drop}) = (Q/C_v)^2$$

Headloss

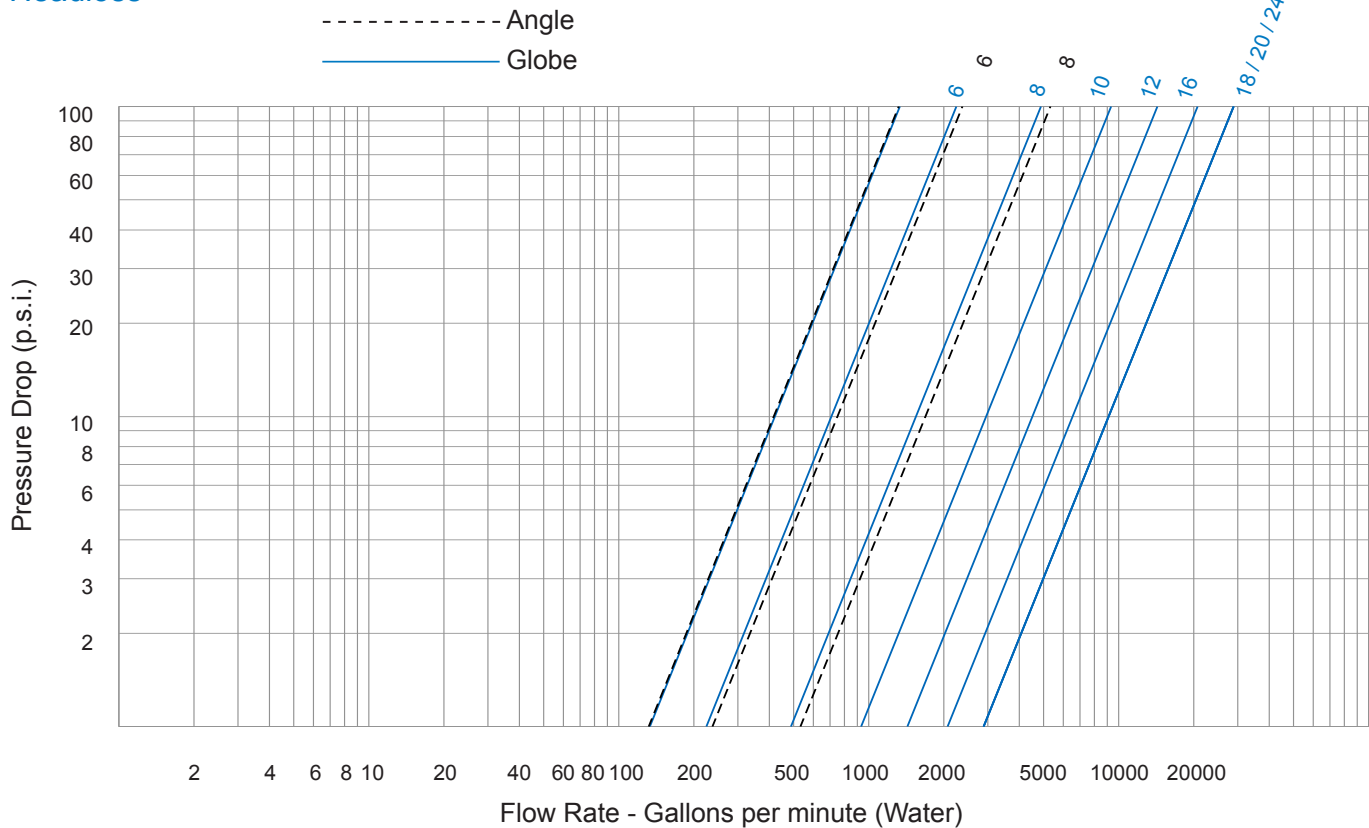

Valve Cover Chamber Capacity

Valve Size (in)	6	8	10	12	16	18	20	24
fl.oz.	22	70						
U.S. Gal			1-1/4	2-1/2	4	9-1/2	9-1/2	9-1/2

Valve Travel

Valve Size (in)	6	8	10	12	16	18	20	24
(in)	1	1-1/2	2	2-1/2	3	4	4	4