

### Standard Materials

Body & Cover: Ductile Iron ASTM A536

Coating: NSF Listed Fusion Bonded Epoxy Lined

Body & Cover: Ductile Iron ASTM A536

Coating: NSF Listed Fusion Bonded Epoxy Lined and Coated

Trim: 316 Stainless Steel

Elastomers: Buna-N (standard)  
EPDM (optional)  
Viton (optional)

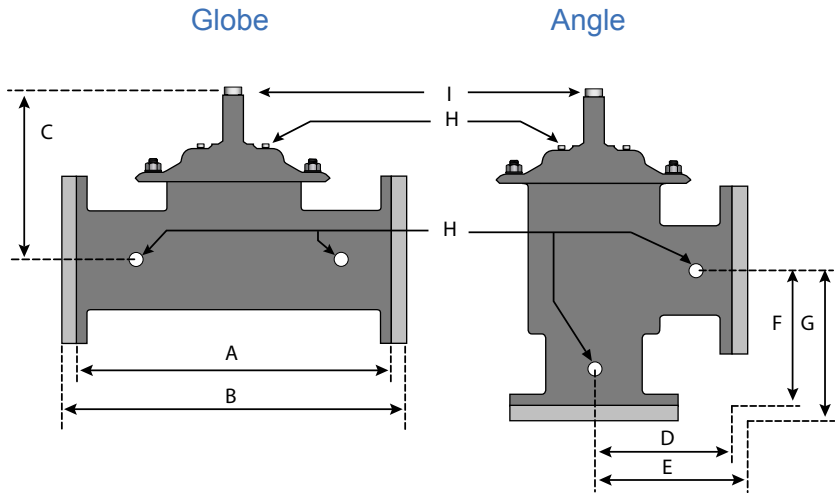

### Dimensions

	A	B	C	D	E	F	G	H	I	
VALVE SIZE	GLOBE 150#	GLOBE 300#	COVER TO CENTER	ANGLE 150#	ANGLE 300#	ANGLE 150#	ANGLE 300#	PORT SIZE	PORT SIZE	SHIPPING WEIGHTS*
6	17-3/4	18-5/8	11-5/8	8-7/8	9-3/8	6-3/4	7-1/4	3/4	3/4	77
8	21-3/8	22-3/8	15	10-11/16	11-3/16	7-1/4	7-3/4	1	3/4	168
10	26	27-3/8	17-7/8					1	1	225
12	30	31-1/2	21					1	1-1/4	376
16	35	36-5/8	25-3/4					1	1-1/4	450
18	48	49-5/8	31					1	1-1/2	850
20	48	49-5/8	31					1	1-1/2	860
24	48	49-3/4	31					1	1-1/2	870

\*Estimated in lbs.

### Description

The Watts ACV Models S6518 and S61518 are reduced port, dual chamber basic valves that incorporate a two-piece telescoping disc and diaphragm assembly. This assembly is the only moving part within the valve, allowing it to open or close as commanded by the pilot control system. The lower portion of this two-piece assembly is a mechanical check feature, which acts independent of diaphragm position or pilot control system, and provides immediate check action when flow ceases.

When pressure is applied to the upper diaphragm chamber and released from the lower diaphragm chamber, the valve travels to a closed position. When pressure is applied to the lower diaphragm chamber and released from the upper diaphragm chamber the valve travels to a full open position.

Model S6518: Globe Pattern Dual Chamber Basic Valve with Mechanical Check Feature

Model S61518: Angle Pattern Dual Chamber Basic Valve with Mechanical Check Feature

### Operating Pressure

Threaded = 400 psi / 150 Flanged = 250 psi / 300 Flanged = 400 psi

### Operating Temperature

Buna-N: 160°F Maximum

EPDM: 300°F Maximum

Viton: 250°F Maximum

## Flow Data - ACV S6518 (Globe) / S61518 (Angle)

Valve Size - Inches	6	8	10	12	16	18	20	24
Maximum Continuous Flow Rate Gpm (Water)	800	1850	3100	5000	7000	11100	11100	11100
Maximum Intermittent Flow Rate Gpm (Water)	1000	2300	4000	6250	8900	14100	14100	14100
C <sub>v</sub> Factor GPM (Globe)	224	489	932	1428	2067	2881	2881	2881
C <sub>v</sub> Factor GPM (Angle)	237	534						

Maximum continuous flow based on velocity of 20 ft. per second.

Maximum intermittent flow based on velocity of 25 ft. per second.

The C<sub>v</sub> factor of a valve is the flow rate in US GPM at 60° F that will cause a 1 psi drop in pressure.

The factors stated are based upon a fully open valve.

C<sub>v</sub> factor can be used in the following equations to determine Flow (Q) and Pressure Drop (Δ P):

$$Q (\text{Flow}) = C_v \sqrt{\Delta P}$$

$$\Delta P (\text{Pressure Drop}) = (Q/C_v)^2$$

## Headloss

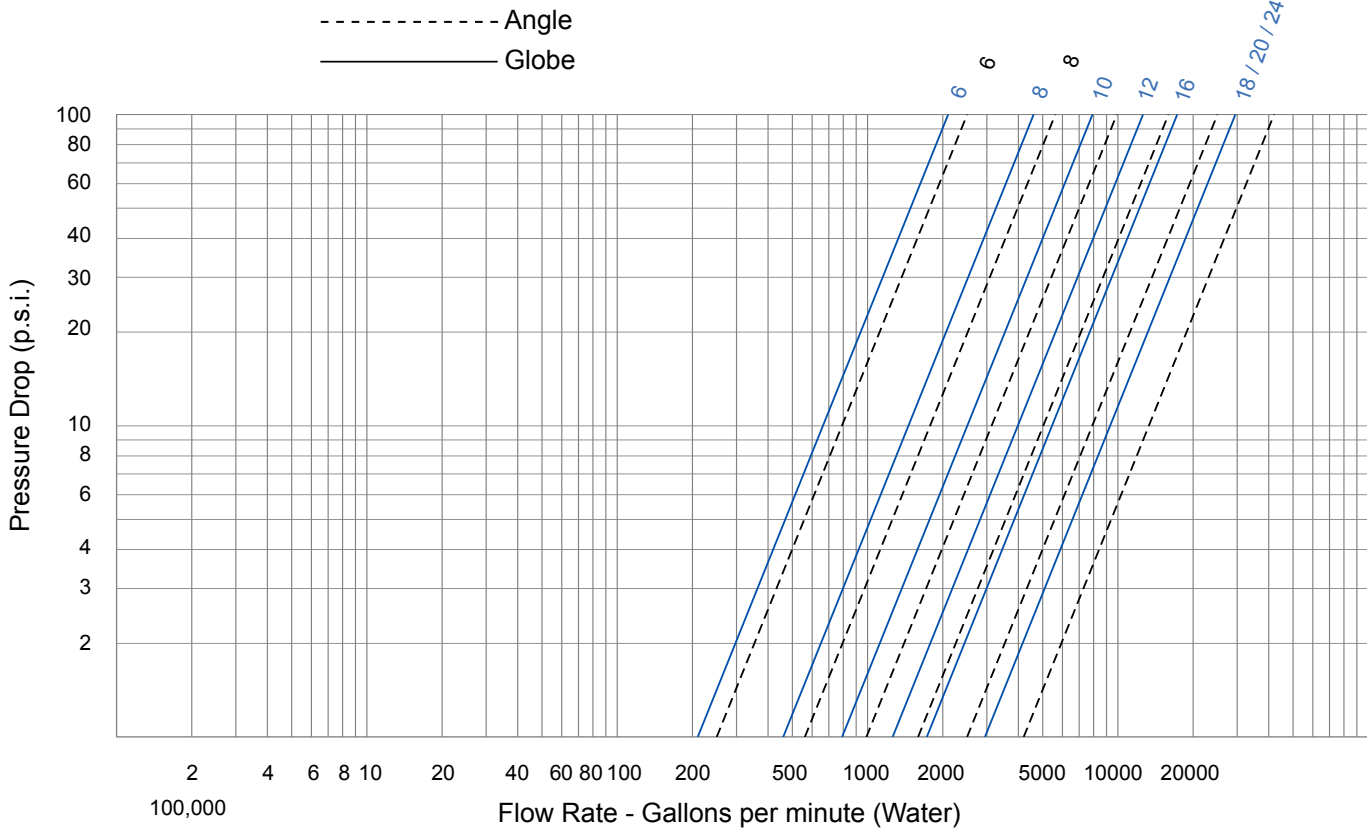

## Valve Cover Chamber Capacity

Valve Size (in)	6	8	10	12	16	18	20	24
fl.oz.	22	70						
U.S. Gal			1-1/4	2-1/2	4	9-1/2	9-1/2	9-1/2

## Valve Travel

Valve Size (in)	6	8	10	12	16	18	20	24
(in)	1	1-1/2	2	2-1/2	3	4	4	4