

LEAD FREE*

920G-UL (Globe)

Fire Pump Relief Valve

Function

Automatically maintains a constant pressure in the fire protection system by relieving excess pressure.

Features

The Ames ACV 920G-UL (Globe) Relief Valve meets all requirements for UL listed, FM Approved fire protection service. The design and features incorporated in the Ames ACV Valves assure accurate control, dependable performance, and long life.

Models

Model 920G-UL: Globe Pattern Single Chamber Relief Valve

Also Available:

Model 920A-UL: Angle Pattern Single Chamber Relief Valve

Materials

Body & Cover:	Ductile Iron ASTM A536
Seat (Trim):	Stainless Steel CF8M - Xylan Coated
Internals:	Stainless Steel S30400 or Ductile Iron ASTM A536 Fusion Bonded Epoxy Coated
Stem:	Stainless Steel S30400 - Xylan Coated
Spring:	Stainless Steel AISI S30200
Elastomers:	Buna-N
Control Tubing:	Copper or Stainless Steel
Fittings:	Brass or Stainless Steel
Pressure Relief Control Body:	Bronze

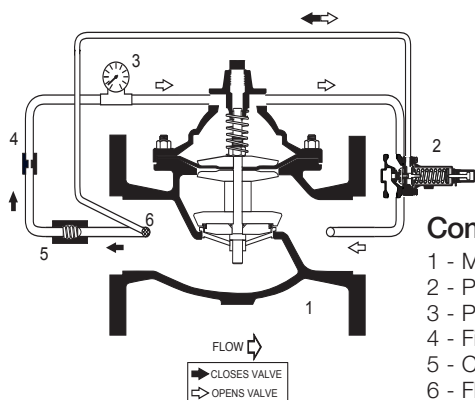

Components

- 1 - Main Valve
- 2 - PV20C Relief Control
- 3 - Pressure Gauge
- 4 - Fixed Orifice
- 5 - Check Valve
- 6 - Flo-Clean Strainer

*The wetted surface of this product contacted by consumable water contains less than 0.25% of lead by weight.

Ames Fire & Waterworks product specifications in U.S. customary units and metric are approximate and are provided for reference only. For precise measurements, please contact Ames Fire & Waterworks Technical Service. Ames Fire & Waterworks reserves the right to change or modify product design, construction, specifications, or materials without prior notice and without incurring any obligation to make such changes and modifications on Ames Fire & Waterworks products previously or subsequently sold.



920G-UL Globe

Valve Sizes Available in Angle and Globe

3"	4"	6"	8"
UL	UL/FM	UL/FM	UL/FM

Sizes / Approvals

20 - 175 PSI Relief Service

100-300 PSI Relief Service

ANSI End Connections 150, 300, and 300 x 150



Operation

The Ames ACV Model 920G-UL PRESSURE RELIEF VALVE is controlled by a Pressure Relief Control. The Pressure Relief Control is normally closed, held closed by an adjustable spring setting to maintain a constant inlet pressure to the main valve.

When upstream pressure increases above the relief set-point, the Relief Control throttles open, increasing flow through the control tubing. Pressure is decreased in the main valve cover chamber, causing the main valve to modulate towards open, relieving excess upstream pressure. The desired system pressure is maintained.

As the upstream pressure decreases below the relief set-point, the Relief Control throttles closed, restricting flow through the control tubing. Pressure is increased in the main valve cover chamber, causing the main valve to modulate towards closed, maintaining the desired upstream pressure. Should upstream pressure drop below and remain below the set-point, the main valve closes drip tight.



920G-UL Fire Pump Relief Valve

Dimensions - ACV 920G-UL (Globe)

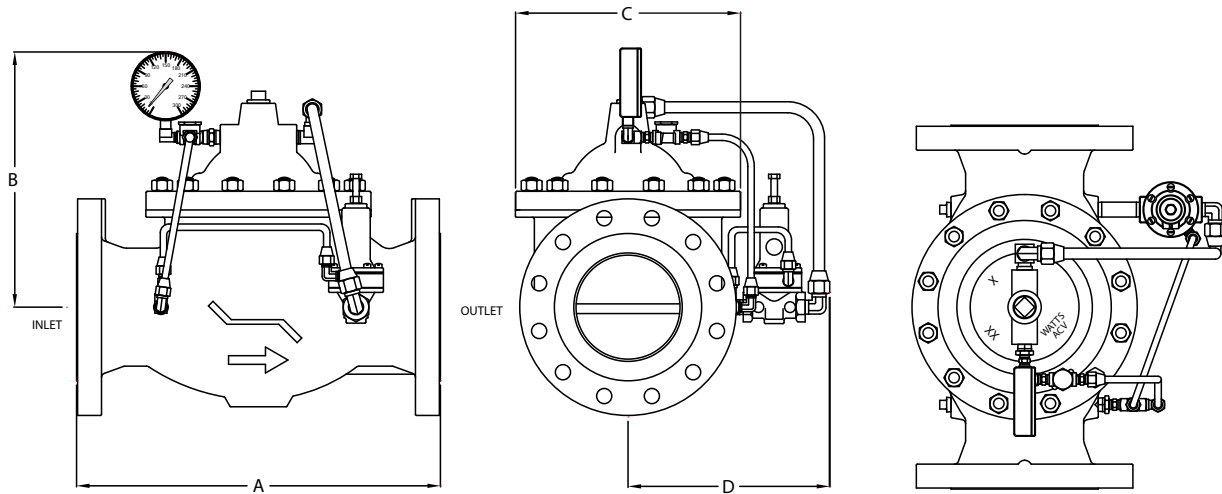

Valve Size		150 Outlet		300 Outlet							
<i>in.</i>	<i>mm</i>	<i>in.</i>	<i>mm</i>	<i>in.</i>	<i>mm</i>	<i>in.</i>	<i>mm</i>	<i>in.</i>	<i>mm</i>	<i>in.</i>	<i>mm</i>
3	80	12	305	13¼	337	10⅞	257	7⅞	200	9¾	248
4	100	15	381	15⅝	397	10½	267	9⅛	252	10	254
6	150	20	508	21	533	15	381	13¼	337	11½	292
8	800	25⅝	645	26⅝	670	18½	470	16	406	13	330

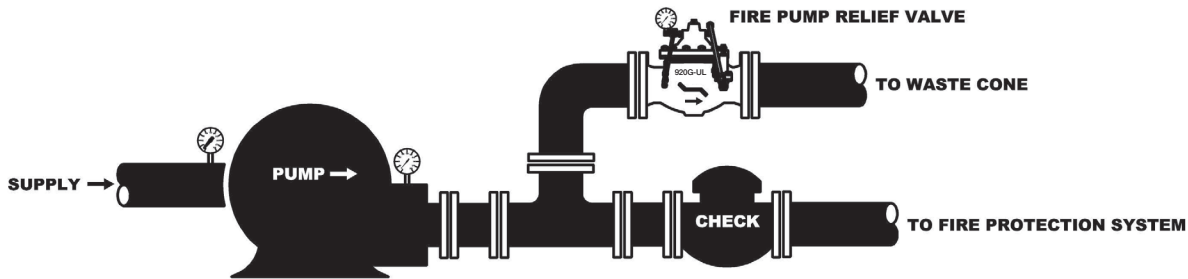

Installation and Start-up

Start-up of an Automatic Control Valve requires following proper procedures. Time must be allowed for the valve to react to adjustments and the system to stabilize. The objective is to bring the valve into service in a controlled manner to protect the system from damaging overpressure.

NOTICE: Avoid mounting valves in a vertical discharge position (valve stem horizontal or cover pointed sideways.) Valves mounted in this position may not perform as tested and approved.

- Clear the line of slag and other debris.
 - Install the valve so that the FLOW ARROW marked on the valve body matches the flow through the line.
 - Install pressure gauge (supplied) in the fitting on valve tubing.
1. Turn the Relief Control adjustment screw counterclockwise (out). This lowers the initial relief set-point, allowing the set-point to be increased to the desired setting.
 2. Loosen a tube fitting at a high point on the valve. This allows the cover to vent trapped air during initial filling of the valve.
 3. Start the pump to supply fluid/pressure to the valve.

4. Tighten the tubing when all air is vented from the cover as indicated by continual flow of fluid.

NOTICE: THE RELIEF SET-POINT SHOULD BE LOWER THAN DESIRED AT THIS TIME.

5. Turn the Relief Control adjustment screw clockwise (in) slowly, allowing time for the pressure to gradually increase to the desired set-point.

NOTICE

The information contained herein is not intended to replace the full product installation and safety information available or the experience of a trained product installer. You are required to thoroughly read all installation instructions and product safety information before beginning the installation of this product.

920G-UL Fire Pump Relief Valve

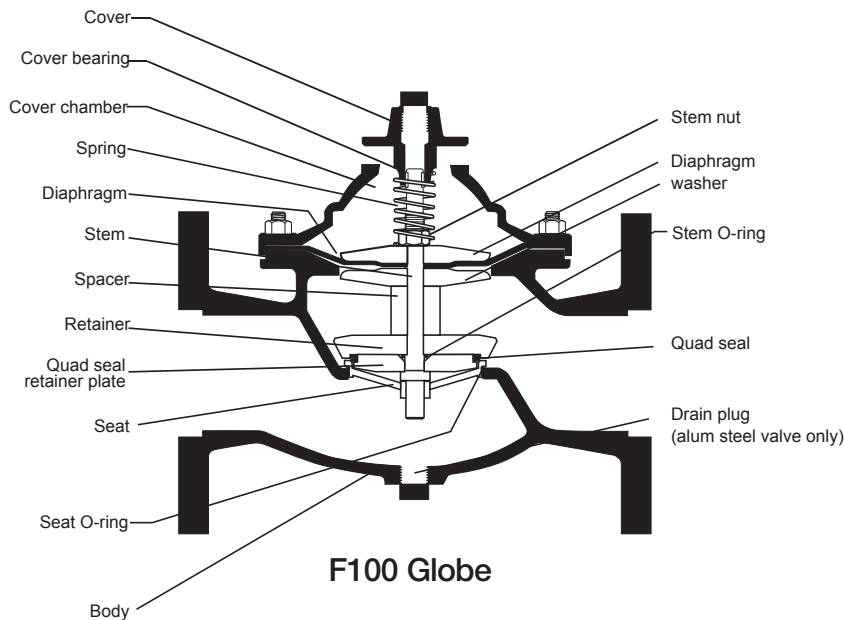

Maintenance

The basic valve normally requires a minimum of maintenance, due to a packless construction and no required lubrication. However, it is suggested that a periodic inspection schedule be established to determine how the fluid is affecting the efficiency of the valve. Fluid velocity as well as any substance entrained in the fluid, such as dissolved minerals and/or suspended particles, vary between installations. In areas subject to freezing, remove the body cover drain plugs for winter drain-down.

NOTICE: The following method will determine if there is a damaged diaphragm without removing the valve cover. Put pressure into the valve and close all control lines to the valve cover chamber. Remove a fitting on the valve cover. If there is a continuous flow out of the cover chamber through this opening, the diaphragm is damaged or the diaphragm assembly on the stem is loose. **CAUTION:** The valve will be wide open during this procedure. Omit if the fully open valve could result in system damage.

Disassembly/Assembly

Inspection or maintenance can be accomplished without removal from the line.

To replace the diaphragm and/or the quad ring:

1. Remove fitting nuts where necessary to release the valve cover from the controls or control lines.
2. Remove the cover and spring.
3. Remove the diaphragm and stem assembly, taking care not to damage the diaphragm when removing over studs.
4. With the assembly removed, examine the diaphragm and quad ring for wear or damage. Do not disassemble unless replacement is indicated.
5. To replace the diaphragm, quad ring and/or stem O-ring, hold the stem in a vise or with wrench on the flats at the bottom end of the stem. Remove the nuts.
6. Remove the diaphragm washer, diaphragm, etc., in the proper sequence.
7. Check all surfaces, seat, O-ring grooves and diaphragm clamping surfaces for damage and/or foreign particles.
8. To reassemble, reverse the order of disassembly. Tighten stem nuts securely to ensure proper clamping of the diaphragm. To assure positive and even clamping of the diaphragm between the body and the cover, gradually tighten the cover nuts diametrically opposite each other.

920G-UL Fire Pump Relief Valve

Flow Data - 905GD (Globe)

	3	4	6	8
Flow Rate GPM (Water)	460	800	1800	3100
Maximum Intermittent Flow Rate GPM (Water)	570	1000	2300	3900
Cv Factor GPM (Globe)	125	220	460	775
Cv Factor GPM (Angle)	170	280	650	1100

Maximum continuous flow based on velocity of 20 ft. per second.

Maximum intermittent flow based on velocity of 25 ft. per second.

The C_v Factor of a valve is the flow rate in US GPM at 60° F that will cause a 1 psi drop in pressure.

The factors stated are based upon a fully open valve.

Cv factor can be used in the following equations to determine Flow (Q) and Pressure Drop (Δ P):

$$Q (\text{Flow}) = C_v \sqrt{\Delta P} \quad \Delta P (\text{Pressure Drop}) = (Q/C_v)^2$$

Headloss

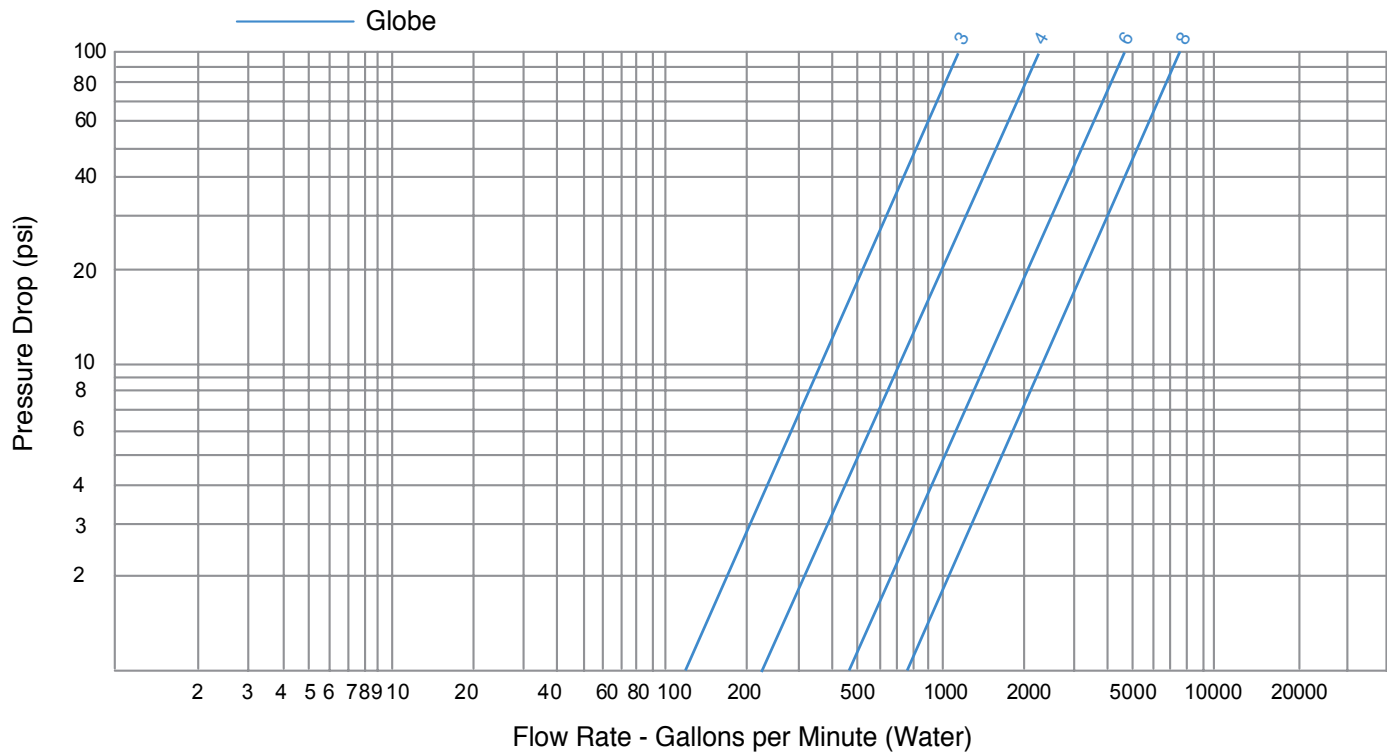

Valve Cover Chamber Capacity

Valve Size - Inches	3	4	6	8
fluid oz.	10	22	70	
U.S. Gal				1-1/4

Valve Travel

Valve Size - Inches	3	4	6	8
Travel - Inches	3/4	1	1-1/2	2



A WATTS Brand



USA: Backflow T: (978) 689-6066 • F: (978) 975-8350 • AmesFireWater.com
USA: Control Valves T: (713) 943-0688 • F: (713) 944-9445 • AmesFireWater.com
Canada: T: (905) 332-4090 • F: (905) 332-7068 • AmesFireWater.ca
Latin America: T: (52) 81-1001-8600 • AmesFireWater.com