

Controls and Accessories

LEAD FREE*

Model CP15-1SS

Pressure Reducing Pilot

Size: 3/8" NPT

The Model CP15-1SS is a remote sensed, direct acting, diaphragm actuated Pilot that is used on various configurations of Automatic Control Valves.

It is normally held open by the force of the adjustable spring setting above the diaphragm. The Pilot modulates towards a closed position when remotely sensed pressure exceeds the spring setpoint, and modulates towards an open position when the remotely sensed pressure falls below the spring setpoint.

Turning the adjustment screw clockwise raises the control setpoint. Turning the adjustment screw counterclockwise lowers the control setpoint.

The Model CP15-1SS is equipped with one 3/8" NPT inlet and three outlet ports for ease of installation, and a 1/8" NPT side sensing port. The 1/8" side sensing port is used to monitor upstream or downstream pressure as required by specific valve function.



CP15-1SS

Specifications

Body Material:	CF8M (316) Stainless Steel
Seat:	316 Stainless Steel
Elastomers:	Buna-N (standard) Viton (optional) EPDM (optional)
Inlet Pressure Rating:	400psi (27.6 bar) maximum
Adjustment Range:	30-300psi (2.1 - 20.7 bar) (standard) 2-30psi (0.15-2 bar) (optional)

Viton® is a registered trademark of DuPont Dow Elastomers.

*The wetted surface of this product contacted by consumable water contains less than 0.25% of lead by weight.

NOTICE

The information contained herein is not intended to replace the full product installation and safety information available or the experience of a trained product installer. You are required to thoroughly read all installation instructions and product safety information before beginning the installation of this product.



Ames Fire & Waterworks product specifications in U.S. customary units and metric are approximate and are provided for reference only. For precise measurements, please contact Ames Fire & Waterworks Technical Service. Ames Fire & Waterworks reserves the right to change or modify product design, construction, specifications, or materials without prior notice and without incurring any obligation to make such changes and modifications on Ames Fire & Waterworks products previously or subsequently sold.

LEAD FREE*

Model CP15-1SS

Pressure Reducing Pilot

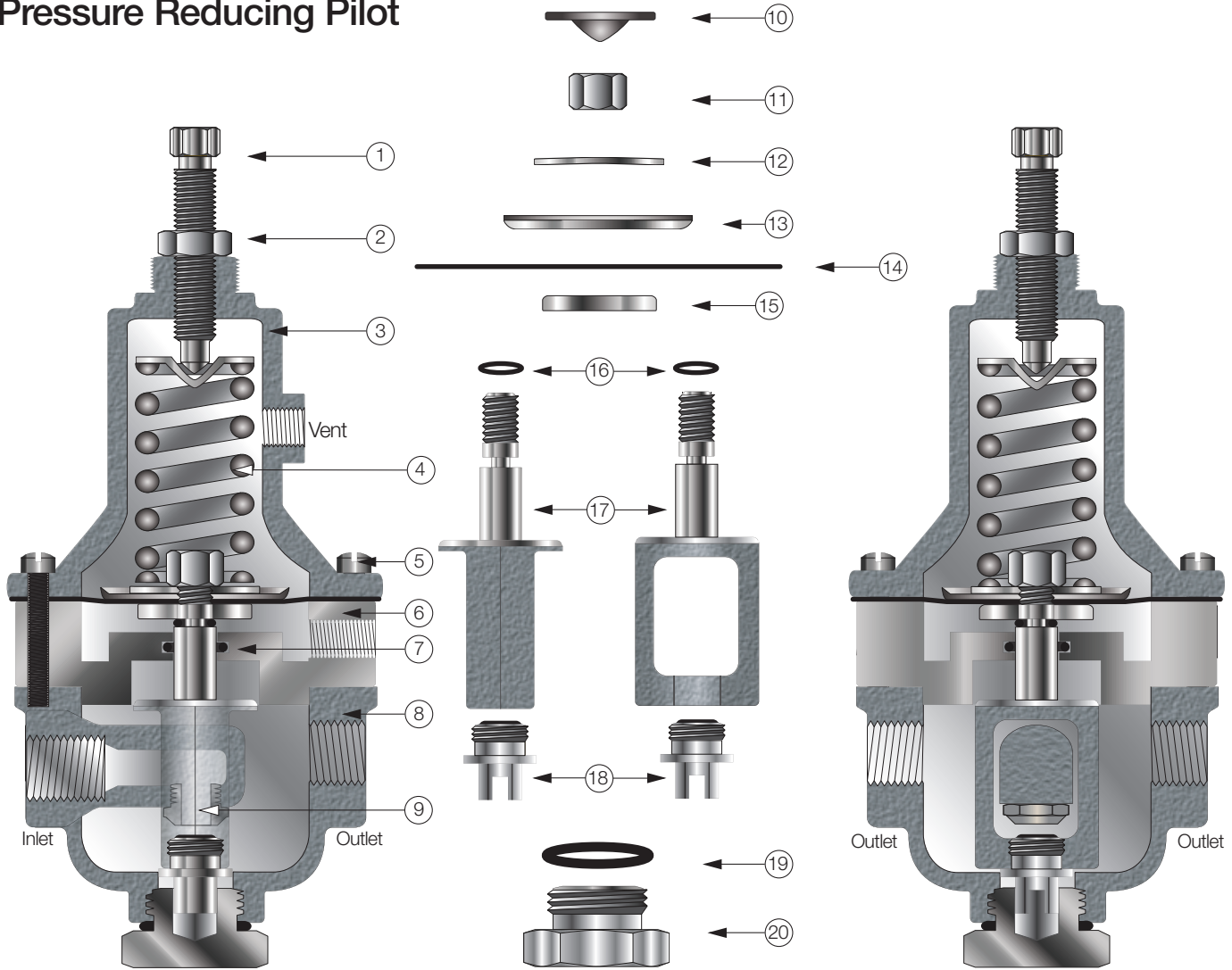

Item	Description
1	Adjusting Screw
2	Nut
3	Spring Housing
4	Springs
5	Cap Screw
6	Power Chamber
7	O-Ring*
8	Body
9	Seat
10	Spring Guide

Item	Description
11	Nut
12	Belleville Washer
13	Diaphragm Washer
14	Diaphragm *
15	Lower Diaphragm Washer
16	O-Ring *
17	Yoke
18	Disc & Retainer Assembly*
19	O-Ring*
20	Bottom Cap

*Included in Repair Kit



A WATTS Brand