

Technical Bulletin

LEAD FREE*

M100D-A (Globe)

Deluge Valve - Pneumatic Hydraulic Actuated

Sizes: 3" - 10"

The Watts ACV M100D-A (Globe) Deluge Valve meets all requirements for UL listed, fire protection service. The design and features incorporated in the Watts ACV Valves assure accurate control, dependable performance, and long life. Opens on demand to provide water flow to the fire protection sprinkler system. Pilot system can be hydraulically, pneumatically, or manually operated. Opening of valve is by loss of control pressure or by manual operation.

Materials

- Body & Cover:**
 - Ductile Iron ASTM A536 65-45-12
 - Fused Red Epoxy inside and out
- Seat (Trim):** Stainless Steel AISI 316 - Xylan Coated
- Stem:** Stainless Steel S30400 - Xylan Coated
- Spring:** Stainless Steel AISI S30200
- Elastomers:** Buna-N
- Pilot:** F100M Control Pilot:
 - Body & Cover - LF Bronze or Stainless Steel
 - Seat & Stem - Stainless Steel AISI 316 (CF8M)
 - Elastomers - BUNA-N (Nitrile)
- Pilot System:**
 - Fittings: Lead Free* Brass or Stainless Steel
 - 3/8" & 1/2" - Control Tubing: Copper or Stainless Steel

Operating Pressure

- 150# Flanged:** ANSI B16.42, 250psi Max Rating
UL Listed Maximum Pressure: 175 PSIG

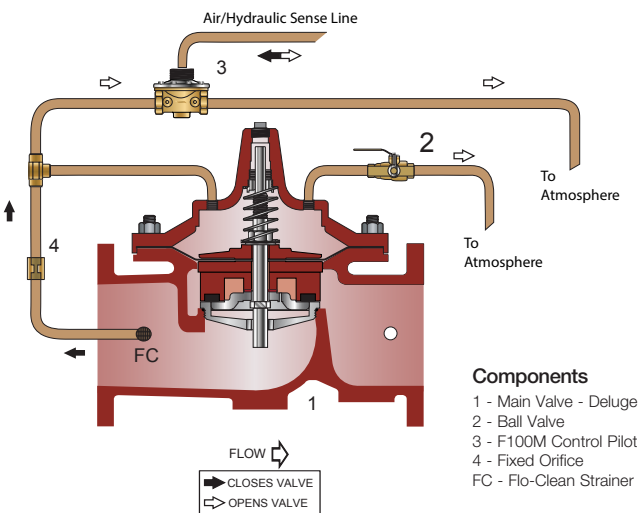

- Components**
- 1 - Main Valve - Deluge
 - 2 - Ball Valve
 - 3 - F100M Control Pilot
 - 4 - Fixed Orifice
 - FC - Flo-Clean Strainer

*The wetted surface of this product contacted by consumable water contains less than 0.25% of lead by weight.

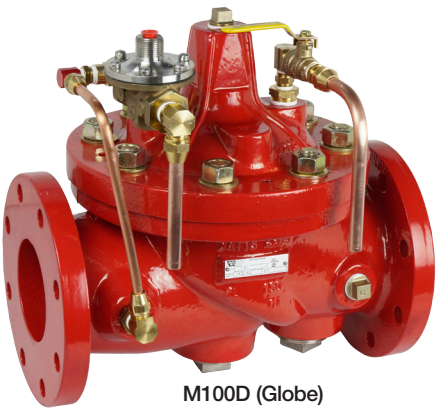

M100D (Globe)

Valve Sizes Available in Globe **US LISTED**
(Horizontal Installation Only)

4"	6"	8"	10"
UL	UL	UL	UL

Additional Sizes Available in Globe
(Vertical Installation Pending UL Listing)

3"	4"	6"	8"	10"
✓	✓	✓	✓	✓

Operation

The Watts ACV Model M100D-A deluge valve is controlled by the F100M control valve pilot, directly actuated by the pneumatic or hydraulic sense line pressure. The F100M pilot supplies or vents pressure to or from the main valve cover chamber, controlling the position of the valve.

When the F100M pilot cover chamber is pressurized the pilot closes, directing the main valve inlet pressure, through a fixed orifice restriction, into the main valve cover chamber. This action pressurizes the main valve cover chamber, closing the main valve.

When the pilot sense line pressure decreases in the cover chamber of the F100M control valve pilot, a diaphragm flexes to unseat a pressure retainer washer / seat inside the F100M allowing it to vent to atmosphere. This action releases the main valve cover chamber pressure, opening the main valve.

An isolation ball valve in the control circuit provides a manual bypass override of the pneumatic / hydraulic control. Opening the ball valve will open the main valve. This ball valve should be CLOSED during normal operation.

NOTE: Sense line pressure must be 30psi or greater for main valve inlet pressure up to 90psi; 50psi for inlet pressure up to 160psi; and 75psi for inlet pressure up to 175psi.

Watts product specifications in U.S. customary units and metric are approximate and are provided for reference only. For precise measurements, please contact Watts Technical Service. Watts reserves the right to change or modify product design, construction, specifications, or materials without prior notice and without incurring any obligation to make such changes and modifications on Watts products previously or subsequently sold.



Deluge System Control Valve

Flow Data - ACV M100D-A (Globe)

Valve Size - Inches		3	4	6	8	10
Suggested	Maximum Continuous Flow Rate Gpm (Water)	485	800	1850	3100	5000
	Maximum Intermittent Flow Rate Gpm (Water)	590	1000	2300	4000	6250
C _v	CV Factor GPM (Globe)	110	185	440	770	1200
	CV Factor GPM (Angle)	125	215	571	990	1530

- Maximum continuous flow based on velocity of 20 ft. per second.
- Maximum intermittent flow based on velocity of 25 ft. per second.
- The C_v Factor of a valve is the flow rate in US GPM at 60°F that will cause a 1psi drop in pressure.
- C_v factor can be used in the following equations to determine Flow (Q) and Pressure Drop (ΔP):

$$Q (\text{Flow}) = C_v \sqrt{\Delta P} \quad \Delta P (\text{Pressure Drop}) = (Q/C_v)^2$$

- The C_v factors stated are based upon a fully open valve.
- Many factors should be considered in sizing control valves including inlet pressure, outlet pressure and flow rates.
- For sizing questions including cavitation analysis consult Watts with system details.

Installation and Start-up

Start-up of a deluge valve requires that proper procedures be followed.

- Clear the line of slag and other debris.
 - Close upstream system isolation valve, if so equipped.
 - Install the valve so that the FLOW ARROW marked on the valve body matches the flow through the line.
 - Ensure that the manual by-pass isolation ball valve is CLOSED.
 - Connect actuating air / hydraulic pressure source to the 1/4" NPTF cover connection of the F100M pilot using 3/8" minimum tubing size.
1. Activate the air / hydraulic pressure source.
 2. Pressurize the line, opening the upstream isolation valve slowly.

3. Partially open the manual ball valve to vent air trapped in the cover chamber. Close when fluid begins to vent. CAUTION: Do not remove or loosen top cover plug while valve is under pressure.
4. Relieve air / hydraulic pressure source from actuation pilot to open the main valve.
5. Actuate the air / hydraulic pressure source to close the main valve.
6. Open manual by-pass ball valve to ensure that the main valve opens. MANUAL BY-PASS BALL VALVE MUST BE CLOSED DURING NORMAL OPERATION OF VALVE.

*Where difficulty in performance is experienced, WATTS ACV or an authorized representative shall be contacted if any field adjustment is to be made.

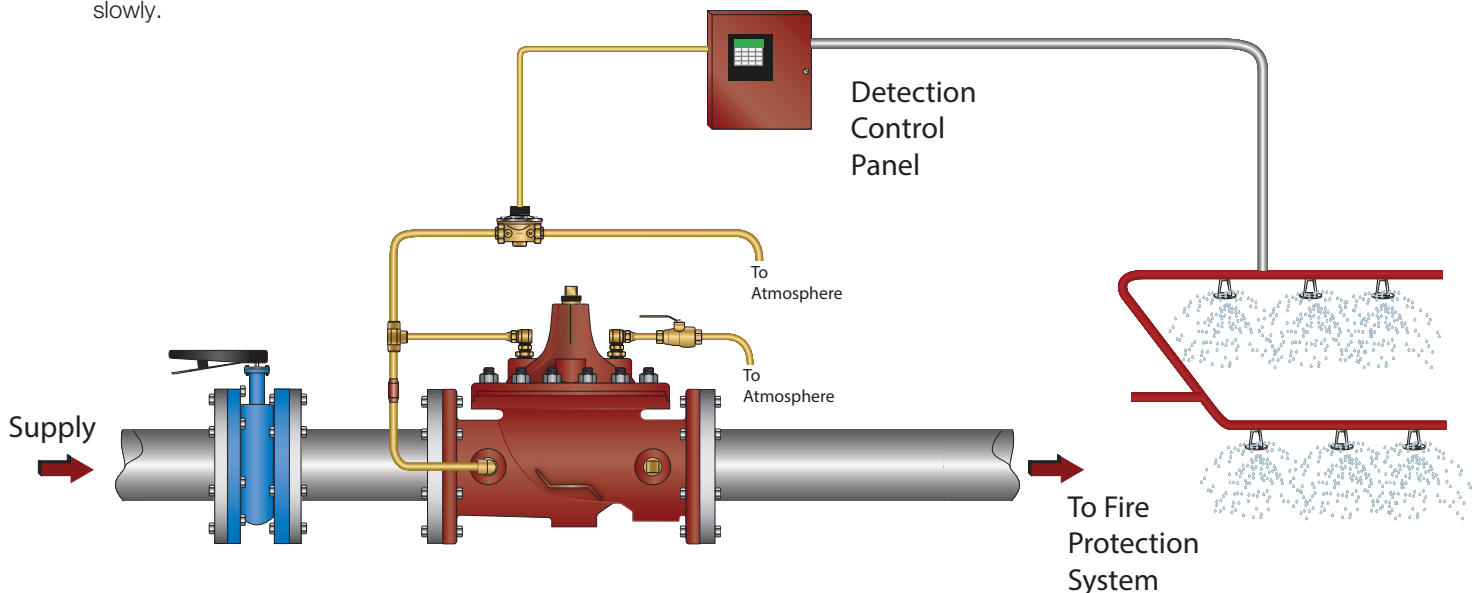

NOTICE

The information contained herein is not intended to replace the full product installation and safety information available or the experience of a trained product installer. You are required to thoroughly read all installation instructions and product safety information before beginning the installation of this product.

NOTICE

Installation: If unit is installed in any orientation other than horizontal (cover up) OR extreme constraints exist, consult customer service prior to or at the time of order.

Deluge System Control Valve

Basic Valve

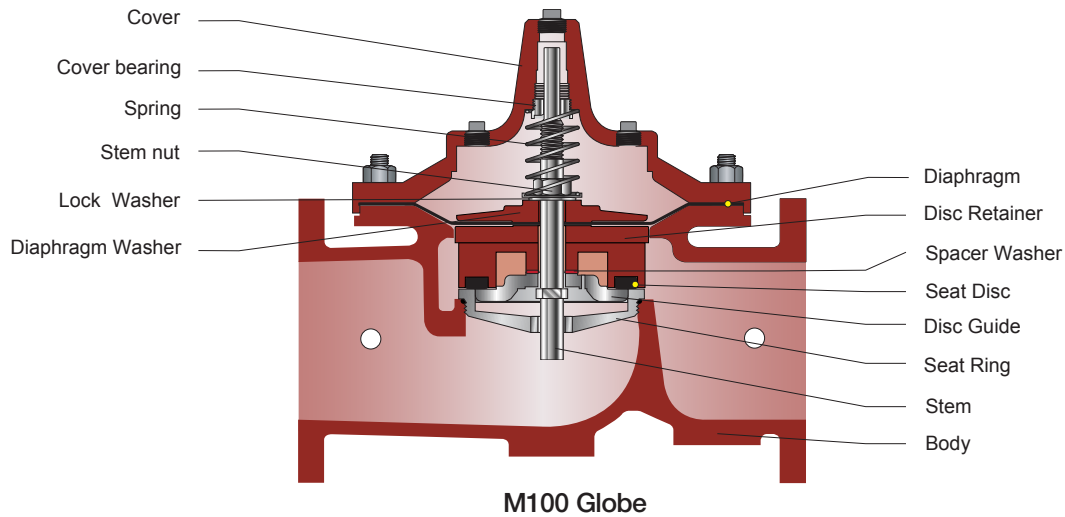

Maintenance

The basic valve normally requires a minimum of maintenance, due to a packless construction and no required lubrication. However, it is suggested that a periodic inspection schedule be established to determine how the fluid is affecting the efficiency of the valve. Fluid velocity as well as any substance entrained in the fluid, such as dissolved minerals and/or suspended particles, vary between installations. In areas subject to freezing, remove the body cover drain plugs for winter drain-down.

Headloss

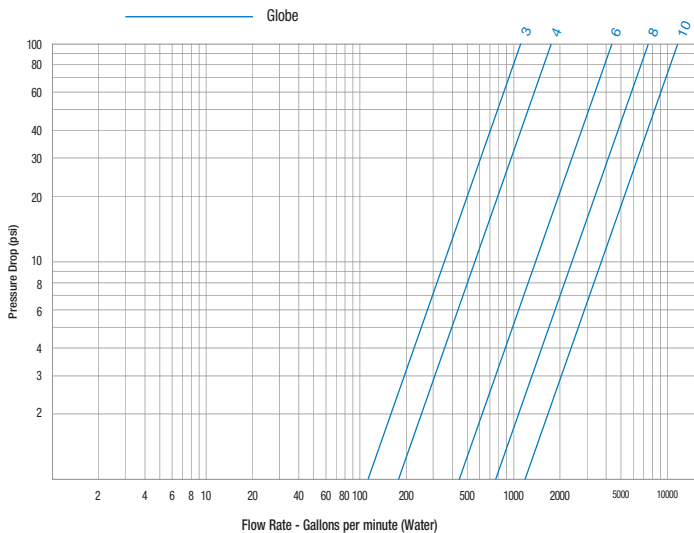

Disassembly/Assembly

Inspection or maintenance can be accomplished without removal from the line.

To replace the diaphragm and/or the Seat Disc:

1. Remove fitting nuts where necessary to release the valve cover from the controls or control lines.
2. Remove the cover and spring.
3. Remove the diaphragm and stem assembly, taking care not to damage the diaphragm when removing over studs.
4. With the assembly removed, examine the diaphragm and Seat Disc for wear or damage. Do not disassemble unless replacement is indicated.
5. To replace the diaphragm, Seat Disc and/or stem O-ring, hold the stem in a vise or with wrench on the flats at the bottom end of the stem. Remove the nuts.
6. Remove the diaphragm washer, diaphragm, etc., in the proper sequence.
7. Check all surfaces, seat, O-ring grooves and diaphragm clamping surfaces for damage and/or foreign particles.
8. To reassemble, reverse the order of disassembly. Tighten stem nuts securely to ensure proper clamping of the diaphragm. To assure positive and even clamping of the diaphragm between the body and the cover, gradually tighten the cover nuts diametrically opposite each other.

Deluge System Control Valve

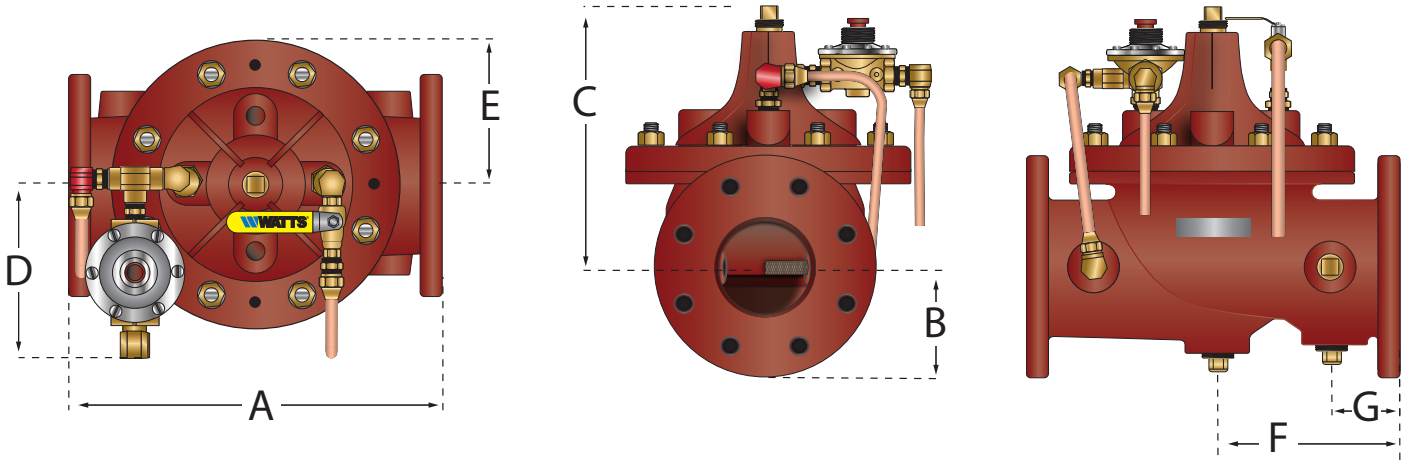

Dimensions

Valve Size		A		B		C		D		E		F		G	
		150#		150#											
<i>in.</i>	<i>mm</i>	<i>in.</i>	<i>mm</i>	<i>in.</i>	<i>mm</i>	<i>in.</i>	<i>mm</i>	<i>in.</i>	<i>mm</i>	<i>in.</i>	<i>mm</i>	<i>in.</i>	<i>mm</i>	<i>in.</i>	<i>mm</i>
3	80	12	305	3.75	95	9.25	235	6.63	168	4.63	118	9.5	241	2.5	64
4	100	15	381	4.5	114	10.62	269	7.81	198	5.81	147	7.5	190	3.46	88
6	150	20	508	5.5	140	13.375	339	9.63	244	7.63	194	10.0	254	3.38	86
8	200	25.375	645	6.75	171	16	406	10.24	260	10.04	255	12.69	322	4.29	109
10	250	29.75	755	8	203	17.125	435	13.83	351	11.83	300	14.88	378	7.16	182



USA: T: (978) 689-6066 • F: (978) 975-8350 • Watts.com
 Canada: T: (905) 332-4090 • F: (905) 332-7068 • Watts.ca
 Latin America: T: (52) 81-1001-8600 • Watts.com