

LEAD FREE*

M100D-B (Globe)

Deluge Valve - Pneumatic Hydraulic Electric Actuated

Sizes: 3" - 10"

The Watts ACV M100D-B (Globe) Deluge Valve meets all requirements for UL listed, fire protection service. The design and features incorporated in the Watts ACV Valves assure accurate control, dependable performance, and long life. Opens on demand to provide water flow to the fire protection sprinkler system. Pilot system can be hydraulically, pneumatically, or manually operated. Opening of valve is by loss of control pressure, electrical signal to solenoid, or by manual operation.

Materials

- Body & Cover:**
 - Ductile Iron ASTM A536 65-45-12
 - Fused Red Epoxy inside and out
- Seat (Trim):** Stainless Steel AISI 316 - Xylan Coated
- Stem:** Stainless Steel S30400 - Xylan Coated
- Spring:** Stainless Steel AISI S30200
- Elastomers:** Buna-N
- Pilot:** F100M Control Pilot:
 - Body & Cover - LF Bronze or Stainless Steel
 - Seat & Stem - Stainless Steel AISI 316 (CF8M)
 - Elastomers - BUNA-N (Nitrile)
- Pilot System:** Fittings: Lead Free* Brass or Stainless Steel
 1/4", 3/8" & 1/2" - Control Tubing: Copper or Stainless Steel
- Solenoid:** Brass or Stainless Steel
 UL Listed Compatible
 Normally Open 3-Way, 120VAC / 24VDC
 Explosion Proof NEMA 4, 7, 9

Operating Pressure

- 150# Flanged:** ANSI B16.42, 250psi Max Rating
 UL Listed Maximum Pressure: 175 PSIG

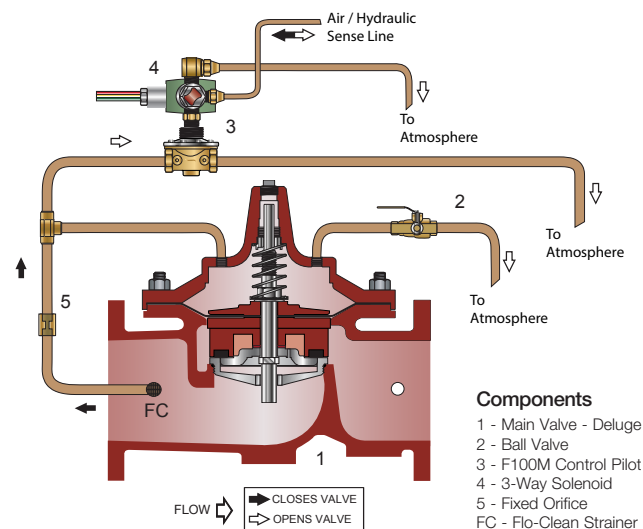

- Components**
- 1 - Main Valve - Deluge
 - 2 - Ball Valve
 - 3 - F100M Control Pilot
 - 4 - 3-Way Solenoid
 - 5 - Fixed Orifice
 - FC - Flo-Clean Strainer

*The wetted surface of this product contacted by consumable water contains less than 0.25% of lead by weight.



M100D-B (Globe)

Valve Sizes Available in Globe cUL US LISTED
 (Horizontal Installation Only)

4"	6"	8"	10"
UL	UL	UL	UL

Additional Sizes Available in Globe
 (Vertical Installation Pending UL Listing)

3"	4"	6"	8"	10"
✓	✓	✓	✓	✓

Operation

The Watts ACV Model M100D-B deluge valve incorporates an electrically operated Normally Open solenoid installed on the cover of the F100M pilot control valve. The solenoid port connections are #1 to cover of F100M pilot, #2 to drain, and #3 to sense line.

When the solenoid is de-energized the Model M100D-B uses the F100M pilot control valve directly with the pneumatic or hydraulic pilot sense line flowing through the ports of the Normally Open solenoid valve. De-energized solenoid ports #3 open to #1, #2 closed. As the pilot line pressure decreases in the cover chamber of the F100M pilot, the diaphragm flexes to unseat a pressure retainer washer / seat inside the F100M pilot which allows the main valve cover pressure to vent to atmosphere through the now open F100M pilot, opening the main valve.

When the solenoid is energized it directly vents the pilot line pressure from the F100M cover to atmosphere which opens to allow the main valve cover to vent to atmosphere through the now open F100M pilot, opening the main valve. Energized solenoid ports #1 open to #2, #3 closed.

An isolation ball valve in the control circuit provides a manual by-pass override of the pneumatic / hydraulic control. Opening the ball valve will open the main valve. This ball valve should be CLOSED during normal operation.

NOTE: Sense line pressure must be 30psi or greater for main valve inlet pressure up to 90psi; 50psi for inlet pressure up to 160psi; and 75psi for inlet pressure up to 175psi.

Watts product specifications in U.S. customary units and metric are approximate and are provided for reference only. For precise measurements, please contact Watts Technical Service. Watts reserves the right to change or modify product design, construction, specifications, or materials without prior notice and without incurring any obligation to make such changes and modifications on Watts products previously or subsequently sold.



Deluge System Control Valve

Flow Data - ACV M100D-B (Globe)

Valve Size - Inches		3	4	6	8	10
Suggested	Maximum Continuous Flow Rate Gpm (Water)	485	800	1850	3100	5000
	Maximum Intermittent Flow Rate Gpm (Water)	590	1000	2300	4000	6250
C _v	CV Factor GPM (Globe)	110	185	440	770	1200
	CV Factor GPM (Angle)	125	215	571	990	1530

- Maximum continuous flow based on velocity of 20 ft. per second.
- Maximum intermittent flow based on velocity of 25 ft. per second.
- The C_v Factor of a valve is the flow rate in US GPM at 60°F that will cause a 1psi drop in pressure.
- C_v factor can be used in the following equations to determine Flow (Q) and Pressure Drop (ΔP):

$$Q (\text{Flow}) = C_v \sqrt{\Delta P} \quad \Delta P (\text{Pressure Drop}) = (Q/C_v)^2$$

- The C_v factors stated are based upon a fully open valve.
- Many factors should be considered in sizing control valves including inlet pressure, outlet pressure and flow rates.
- For sizing questions including cavitation analysis consult Watts with system details.

Installation and Start-up

Start-up of a deluge valve requires that proper procedures be followed.

- Clear the line of slag and other debris.
 - Close upstream system isolation valve, if so equipped.
 - Install the valve so that the FLOW ARROW marked on the valve body matches the flow through the line.
 - Ensure that the manual by-pass isolation ball valve is CLOSED.
 - Connect actuating air/hydraulic pressure source to port 3 of the solenoid control using 3/8 minimum tubing size.
 - Connect electric Solenoid Valve to a compatible Release Control Panel and compatible detection devices.
1. Energize the solenoid to check actuation and to confirm connection to power source.
 2. De-energize the solenoid for initial valve filling.
 3. Activate the air/hydraulic pressure source.
 4. Pressure the line, opening the upstream isolation valve slowly.

5. Partially open the manual ball valve to vent air trapped in the cover chamber. Close when fluid begins to vent. CAUTION: Do not remove or loosen top plug while valve is under pressure.
6. Energize the solenoid. This will vent the pneumatic/hydraulic control cover chamber, causing the main valve to open.
7. De-energize the solenoid. This will pressure the pneumatic/hydraulic control cover chamber, causing the main valve to close.
8. Open the manual by-pass valve to ensure that the main valve opens. MANUAL BY-PASS BALL VALVE MUST BE CLOSED DURING NORMAL OPERATION OF VALVE.

*Where difficulty in performance is experienced, WATTS ACV or an authorized representative shall be contacted if any field adjustment is to be made.

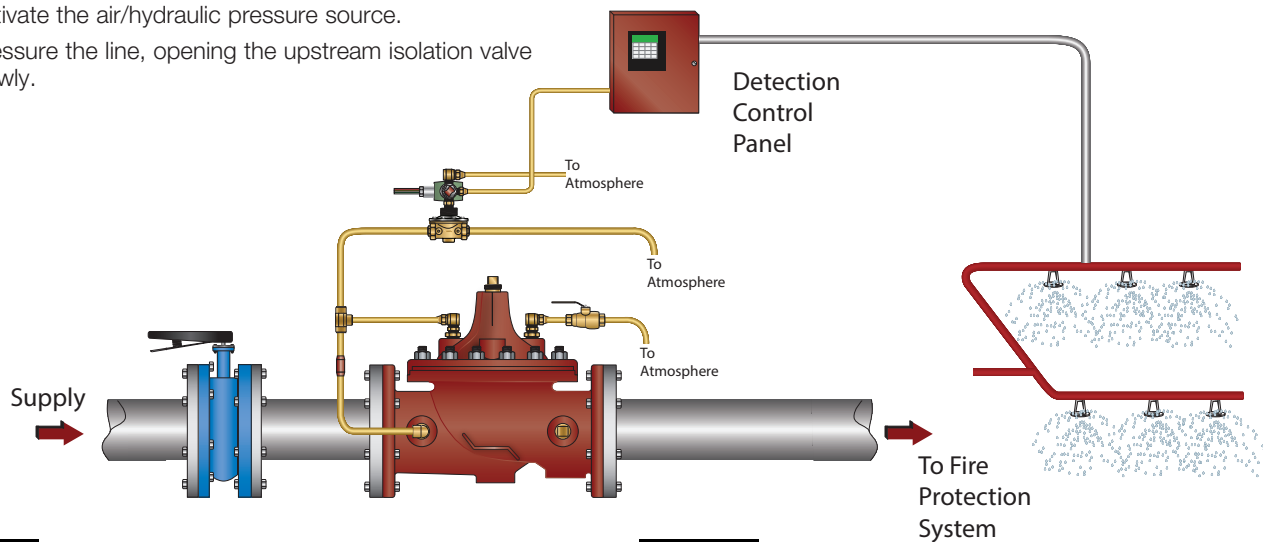

NOTICE

The information contained herein is not intended to replace the full product installation and safety information available or the experience of a trained product installer. You are required to thoroughly read all installation instructions and product safety information before beginning the installation of this product.

NOTICE

Installation: If unit is installed in any orientation other than horizontal (cover up) OR extreme constraints exist, consult customer service prior to or at the time of order.

Deluge System Control Valve

Basic Valve

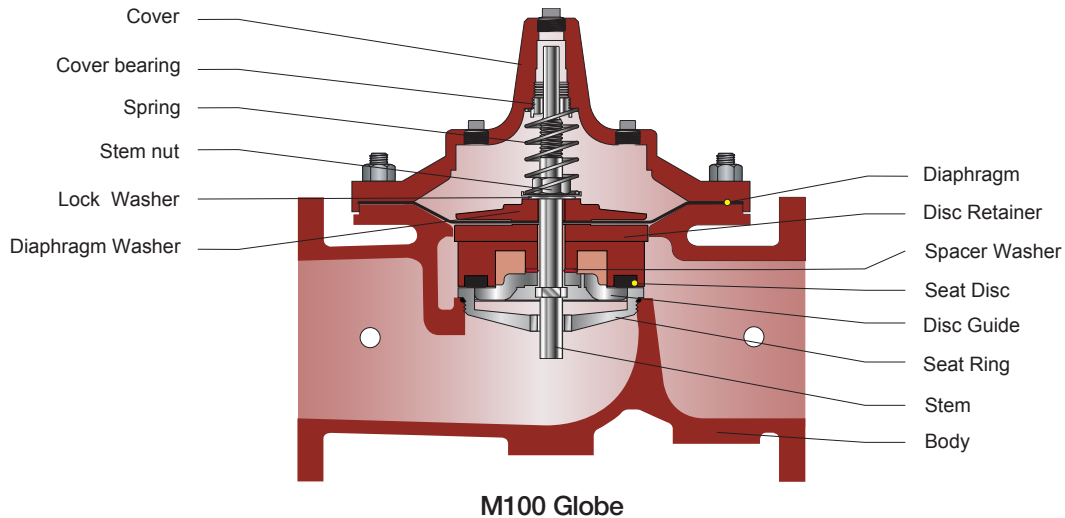

M100 Globe

Maintenance

The basic valve normally requires a minimum of maintenance, due to a packless construction and no required lubrication. However, it is suggested that a periodic inspection schedule be established to determine how the fluid is affecting the efficiency of the valve. Fluid velocity as well as any substance entrained in the fluid, such as dissolved minerals and/or suspended particles, vary between installations. In areas subject to freezing, remove the body cover drain plugs for winter drain-down.

Headloss

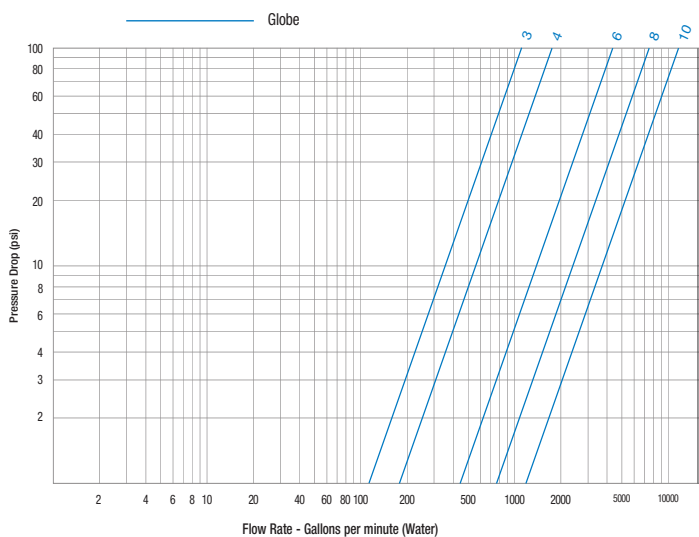

Disassembly/Assembly

Inspection or maintenance can be accomplished without removal from the line.

To replace the diaphragm and/or the Seat Disc:

1. Remove fitting nuts where necessary to release the valve cover from the controls or control lines.
2. Remove the cover and spring.
3. Remove the diaphragm and stem assembly, taking care not to damage the diaphragm when removing over studs.
4. With the assembly removed, examine the diaphragm and Seat Disc for wear or damage. Do not disassemble unless replacement is indicated.
5. To replace the diaphragm, Seat Disc and/or stem O-ring, hold the stem in a vise or with wrench on the flats at the bottom end of the stem. Remove the nuts.
6. Remove the diaphragm washer, diaphragm, etc., in the proper sequence.
7. Check all surfaces, seat, O-ring grooves and diaphragm clamping surfaces for damage and/or foreign particles.
8. To reassemble, reverse the order of disassembly. Tighten stem nuts securely to ensure proper clamping of the diaphragm. To assure positive and even clamping of the diaphragm between the body and the cover, gradually tighten the cover nuts diametrically opposite each other.

Deluge System Control Valve

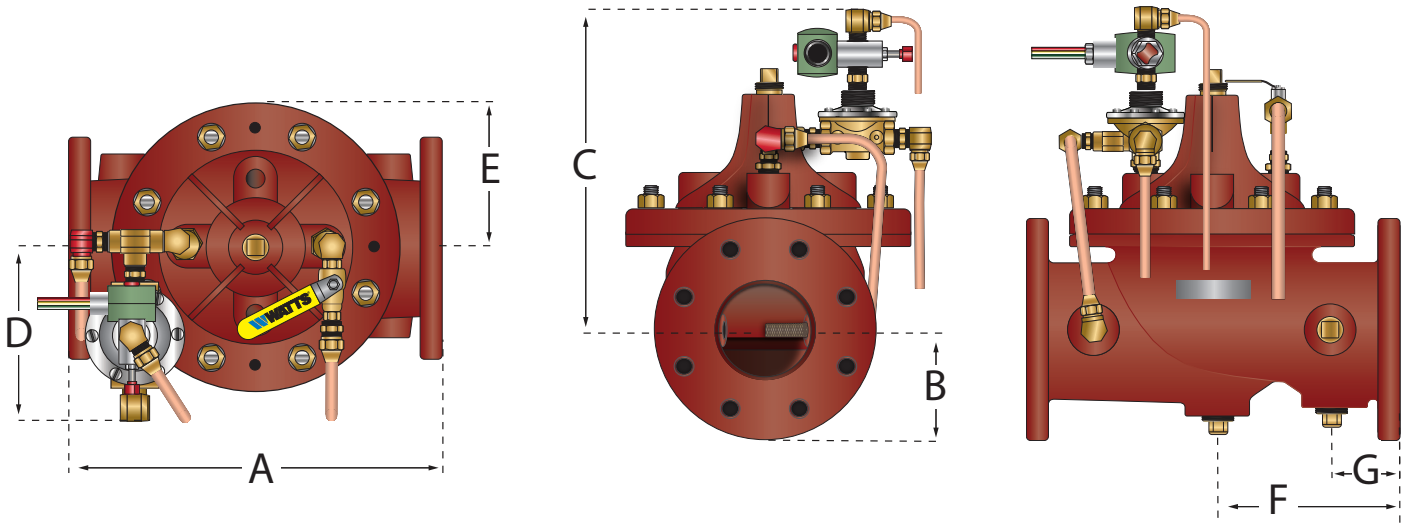

Dimensions

Valve Size		A		B		C		D		E		F		G	
		150#		150#											
<i>in.</i>	<i>mm</i>	<i>in.</i>	<i>mm</i>	<i>in.</i>	<i>mm</i>	<i>in.</i>	<i>mm</i>	<i>in.</i>	<i>mm</i>	<i>in.</i>	<i>mm</i>	<i>in.</i>	<i>mm</i>	<i>in.</i>	<i>mm</i>
3	80	12	305	3.75	95	12.75	324	6.63	168	4.63	118	9.5	241	2.5	64
4	100	15	381	4.5	114	14.375	365	7.81	198	5.81	147	7.5	190	3.46	88
6	150	20	508	5.5	140	15.875	403	9.63	244	7.63	194	10.0	254	3.38	86
8	200	25.375	645	6.75	171	17.875	454	10.24	260	10.04	255	12.64	321	4.29	109
10	250	29.75	755	8	203	18.125	460	13.83	351	11.83	300	14.88	378	7.16	182



USA: T: (978) 689-6066 • F: (978) 975-8350 • Watts.com
 Canada: T: (905) 332-4090 • F: (905) 332-7068 • Watts.ca
 Latin America: T: (52) 81-1001-8600 • Watts.com