

SERIES LSC

LARGE SELF-CLEANING FILTERS

Large Self-Cleaning Filters for underground installation are engineered for commercial and residential rainwater system applications with coverage areas up to 16,000 square feet. Self-cleaning filters provide up to 95% recovery of rainwater from rooftops and feature a removable stainless steel wire mesh filter element for ease of maintenance. Screens separate solids larger than 350 microns, which helps ensure litter free water in water storage systems.

ADVANTAGES

- Easily serviced filter element
- Up to 95% rainwater recovery
- Quick two step installation
- Reduced maintenance design with stainless steel filter

FEATURES

- Can manage roof areas up to 16,000 Sq. Ft.
- Standard 6 or 8 inch (150 or 200mm) diameter ports
- Lockable access cover
- Rust proof thermoplastic construction
- Optional telescoping riser to adjust for site conditions
- Optional solid cast iron cover

HOW TO ORDER – OPTIONS

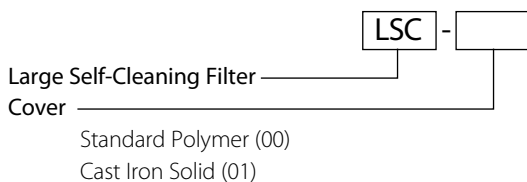

NOTICE

The information contained herein is not intended to replace the full product installation and safety information available or the experience of a trained product installer. You are required to thoroughly read all installation instructions and product safety information before beginning the installation of this product.

BRAE product specifications in U.S. customary units and metric are approximate and are provided for reference only. For precise measurements, please contact BRAE Technical Service. BRAE reserves the right to change or modify product design, construction, specifications, or materials without prior notice and without incurring any obligation to make such changes and modifications on BRAE products previously or subsequently sold.

Job Name _____

Job Location _____

Engineer _____

Approval _____

Contractor _____

Approval _____

Contractor's P.O. No. _____

Representative _____

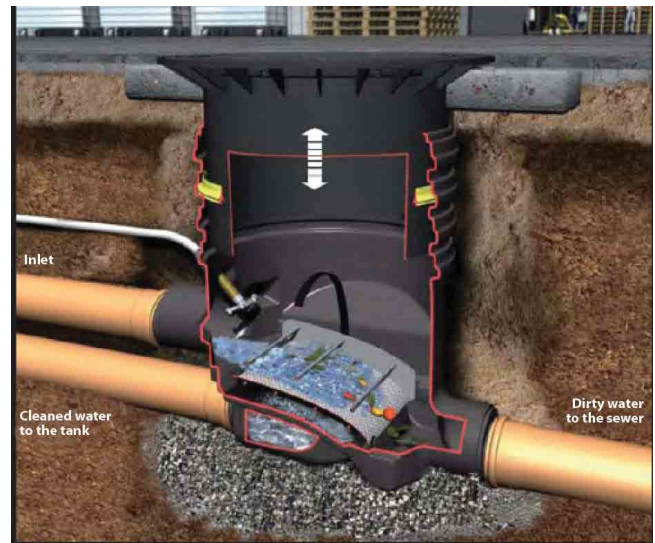

Series LSC

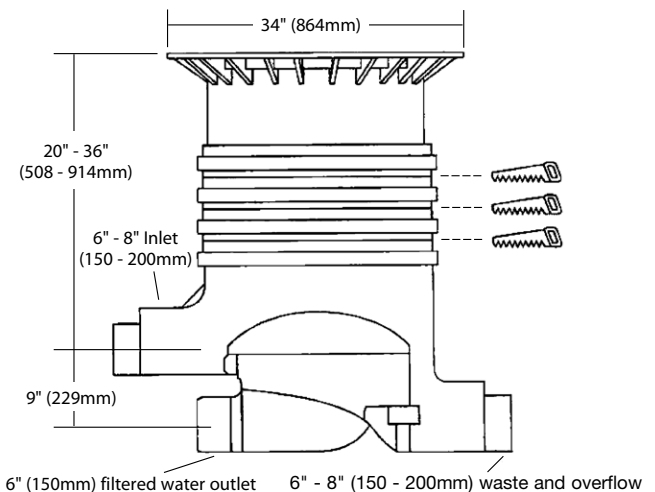

⚠ WARNING

Rainwater supplied by BRAE rainwater harvesting systems is not potable water and is not intended for potable water applications. Do Not Drink Water supplied from BRAE rainwater systems and related equipment. Users shall determine the suitability of the product for the intended application before using.



A WATTS Brand



USA: T: (800) 772-1958 • F: (704) 485-8032 • BRAEWater.com
 Canada: T: (905) 332-4090 • F: (905) 332-7068 • BRAEWater.ca
 Latin America: T: (52) 81-1001-8600 • F: (52) 81-8000-7091 • BRAEWater.com