

SPECIFICATION SHEET **FEBCO**

Series 601-M

Air Gap Drains for Use With MasterSeries® Reduced Pressure Assembly

Sizes: 2½" - 10" (65mm-250mm)



Air Gap Drain Kit

The FEBCO Series 601 Air Gap Drain Kit is constructed of coated aluminum. The air gap drain is designed to be attached to the relief valve of MasterSeries® reduced pressure assemblies, sizes 2½" - 10" (65mm - 250mm). Four inch drainage piping may be attached to drain, creating a system that catches and removes minor relief valve discharges due to pressure fluctuations and/or minor check valve fouling.

Note: The gap drain is not designed to catch the maximum discharge possible from the relief valve. The installation of FEBCO air gap with the drain line terminating above a floor drain will handle any normal discharge or nuisance spitting through the relief valve. However, floor drain size may need to be designed to prevent water damage caused by a catastrophic failure condition. Do not reduce the size of the drain line from the air gap fitting.

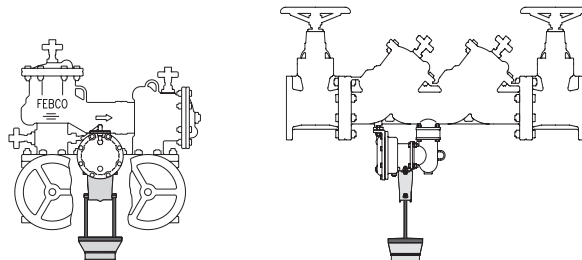

Airgap Drain Front View Series 880

Airgap Drain Side View Series 860

Part Number: 905213

Features

- Nozzle design directs flow directly into funnel, reducing side spray.
- Funnels minor relief valve discharges into drains.
- Lightweight for easy installation.
- Coated for corrosion resistance.
- 4" (100mm) funnel outlet is designed to accept a hubless pipe coupling for simple drain pipe installation.

Materials

- Nozzle: ASTM B26 Alloy 356
- Funnel: ASTM B26 Alloy 356
- Rods: ASTM B241 Alloy 6063 Coating Pratt & Lambert, Inc. Vitralon polyurethane coating black # 88-1204 or equivalent

Dimensions and Weights

Size: 2½"-10" (65mm-250mm)

DIMENSIONS												WEIGHTS					
A		B		C		D		E		F		G		H		lbs.	kgs.
in.	mm	in.	mm	in.	mm	in.	mm	in.	mm	in.	mm	in.	mm	in.	mm		
13⅞	333	6⅜	162	5⅞	137	3½	89	3⅓⅙	97	2⅞	56	4⅞	111	9⅞	251	2.2	1.0

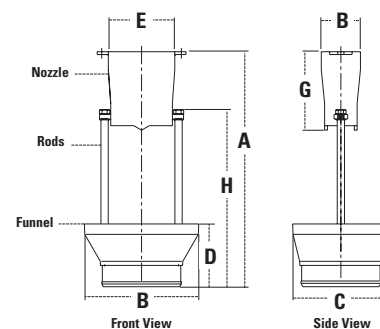

Job Name _____

Job Location _____

Engineer _____

Approval _____

Contractor _____

Approval _____

Contractor's P.O. No. _____

Representative _____



FEBCO product specifications in U.S. customary units and metric are approximate and are provided for reference only. For precise measurements, please contact FEBCO Technical Service. FEBCO reserves the right to change or modify product design, construction, specifications, or materials without prior notice and without incurring any obligation to make such changes and modifications on FEBCO products previously or subsequently sold.

