

Series FPHB-1 Key Operated Wall Hydrants

Sizes: 3/4" - 1" (20 – 25mm)

Series FPHB-1 Key Operated Wall Hydrants have been specifically designed to provide outside access to a building water supply for start-up, winterizing, and servicing of irrigation sprinkler systems. The FPHB-1 is located outside of the home reducing the time spent on service calls. There is no need to locate the inside shutoff valve or the drain connection. Deploying the FPHB-1 wall hydrant enables the irrigation contractor to winterize an irrigation system at anytime thereby protecting the contractors' warranty and the homeowners' investment.

When used in conjunction with the FEBCO Series 767 Pressure Vacuum Breaker or either a Series 825Y or 860 Reduced Pressure Zone Backflow Preventer, the installing contractor provides affordable freeze protection for both the irrigation system and the backflow preventer.

Features

- Eliminates delays and multiple visits to gain interior access to irrigation equipment
- Standardizes location of supply shutoff valve and drain connection
- Access available anytime for winterizing
- Durable bronze valve body and shaft
- One piece valve plunger
- Tamper resistant key operated hydrant
- Exterior chrome finish
- Resilient seated shutoff
- Union connection for ease of installation of backflow preventer
- Manual drain port

Specifications

A drainable freezeless wall hydrant shall be installed outside as shown, to provide a means of shutting off the flow of water to the irrigation system for winterizing the system and the backflow preventer. The valve body and shaft shall be of copper or brass construction with a one piece valve plunger to control both flow and drain functions. The hydrant shall be designed to include a drain plug for winterization of the irrigation system and backflow preventer. The hydrant shall be tamper resistant and shall be key operated. The hydrant shall be 3/4" or 1" (20 or 25mm) size and of the proper length for the installation and shall be a FEBCO Series FPHB-1.

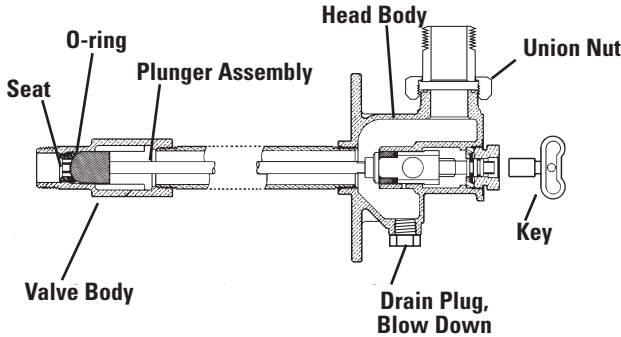
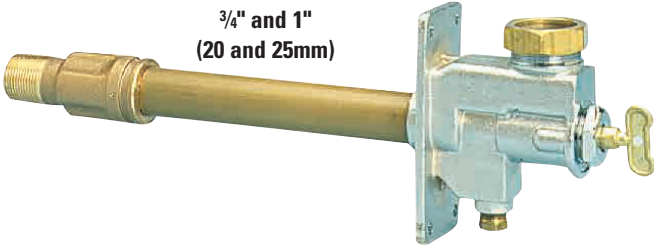

⚠ WARNING

It is illegal to use this product in any plumbing system providing water for human consumption, such as drinking or dishwashing, in the United States. Before installing standard material product, consult your local water authority, building and plumbing codes.

Job Name _____	Contractor _____
Job Location _____	Approval _____
Engineer _____	Contractor's P.O. No. _____
Approval _____	Representative _____

FEBCO product specifications in U.S. customary units and metric are approximate and are provided for reference only. For precise measurements, please contact FEBCO. FEBCO reserves the right to change or modify product design, construction, specifications, or materials without prior notice and without incurring any obligation to make such changes and modifications on FEBCO products previously or subsequently sold.

Materials

- Chrome plated bronze valve head.
- Brass shaft with threaded end.

Pressure - Temperature

Temperature Range: 33°F - 140°F (0.5°C - 60°C) continuous,
180°F (82°C) intermittent

Maximum Working Pressure: 175psi (12.1 bar)

Capacity

*Typical maximum system flow rate (7.5 feet/second)

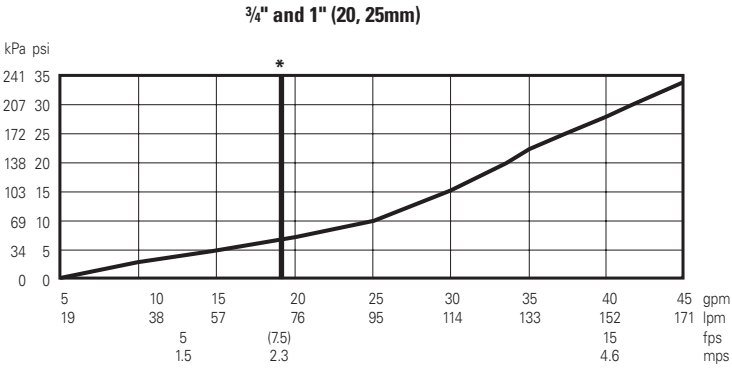

Dimensions

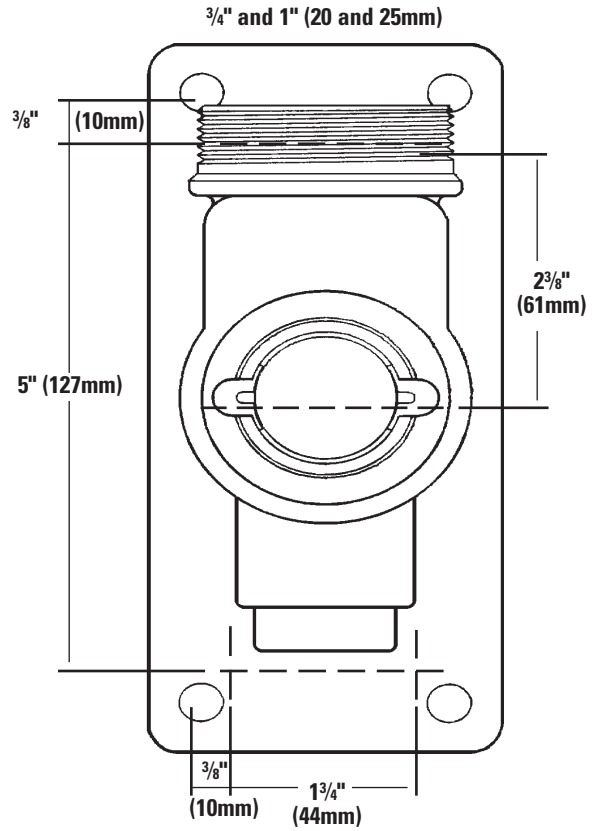

Size: 3/4" - 1" (20 - 25mm)

MODEL	DISTANCE (DN)		PIPE LENGTH		STEM LENGTH	
	in.	mm	in.	mm	in.	mm
FPHB-1-8	8	200	9	229	12 ⁵ / ₁₆	313
FPHB-1-10	10	250	11	279	14 ⁵ / ₁₆	364
FPHB-1-12	12	300	13	330	16 ⁵ / ₁₆	389

Typical Installation

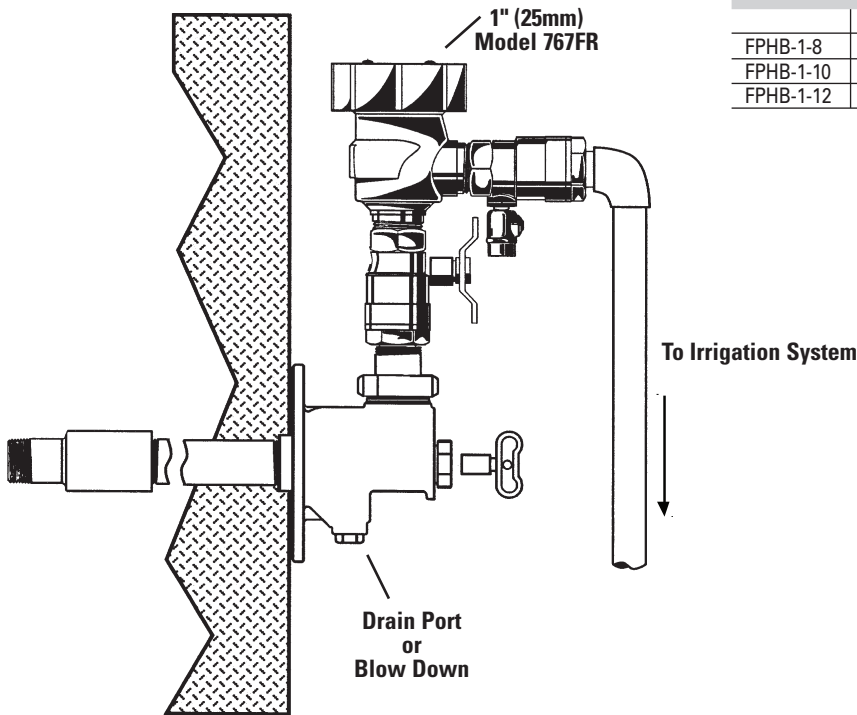

A Watts Water Technologies Company

USA: Tel: (800) 767-1234 • Fax: (800) 788-4491 • FEBCOonline.com

Canada: Tel: (905) 332-4090 • Fax: (905) 332-7068 • FEBCOonline.ca

Latin America: (52) 81-1001-8600 • Fax: (52) 81-8000-7091 • FEBCOonline.com