

SPECIFICATION SHEET

Series PRV-2 Water Pressure Reducing Valves*

Sizes: 1 1/4" – 2" (32 – 50mm)

Series PRV-2 Water Pressure Reducing Valves are designed to reduce incoming water pressure to a sensible level to protect plumbing system components and reduce water consumption. This series is suitable for water supply pressures up to 300psi (21 bar) and may be adjusted from 25 – 75psi (172 – 517 kPa). The standard setting is 50psi (345 kPa). All parts are quickly and easily serviceable without removing the valve from the line. The standard bypass feature permits the flow of water back through the valve into the main when pressures, due to thermal expansion on the outlet side of the valve, exceed the pressure in the main supply.

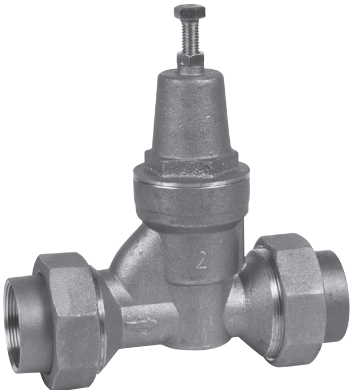

Series PRV-2-DU – 2" (50mm) size shown

Features

- Bronze cage
- Double union inlet & outlet connections
- Integral stainless steel strainer
- Thermoplastic seat
- Bronze body construction
- Serviceable in line
- Bypass feature controls thermal expansion pressure**
- Sealed spring cage on all models for waterworks pit installations

Models

PRV-2	NPT threaded female inlet x NPT female outlet
PRV-2-U	NPT threaded union inlet x NPT female outlet
PRV-2-DU	Double Union – NPT threaded union female inlet and outlet

Specifications

A Water Pressure Reducing Valve and strainer shall be installed on the water service pipe near its entrance to the building where supply main pressure exceeds 60psi (413 kPa) to reduce it to 50psi (345 kPa) or lower. Provision shall be made to permit the bypass flow of water back through the valve into the main when pressures, due to thermal expansion on the outlet side of the valve, exceed the pressure in the main supply. Water pressure reducing valves with built-in bypass check valves and integral strainer will be acceptable. Approved valves shall comply with ASSE 1003, CSA B356 and IAPMO. Valve shall be a FEBCO Company Series PRV-2.

* A water saving test program concluded that reducing the supply pressure from 80 – 50psi (551 – 346 kPa) resulted in a water savings of 30%.

** Note: The bypass feature will not prevent the pressure relief valve from opening on the hot water supply system with pressure above 150psi (10.3 bar).

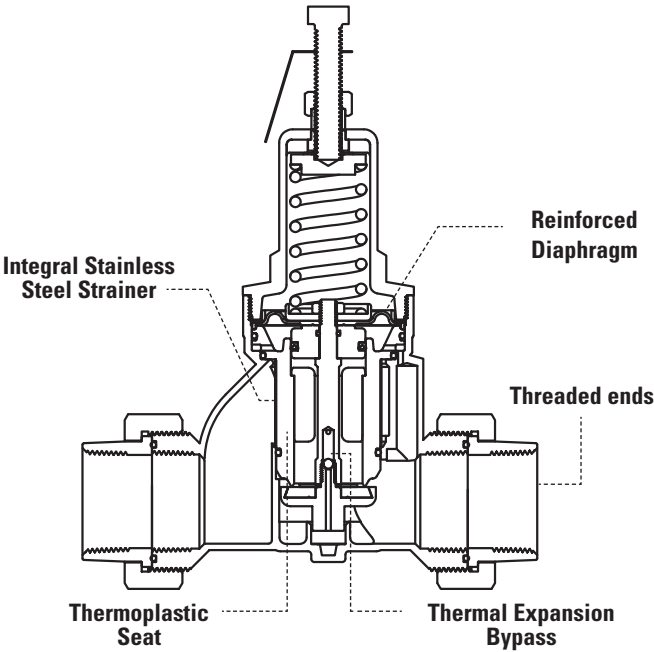

Job Name _____

Job Location _____

Engineer _____

Approval _____

Contractor _____

Approval _____

Contractor's P.O. No. _____

Representative _____

FEBCO product specifications in U.S. customary units and metric are approximate and are provided for reference only. For precise measurements, please contact FEBCO Technical Service. FEBCO reserves the right to change or modify product design, construction, specifications, or materials without prior notice and without incurring any obligation to make such changes and modifications on FEBCO products previously or subsequently sold.

Materials

Body:	Bronze
Seat:	Thermoplastic
Cage:	Bronze
Integral Strainer:	Stainless steel
Diaphragm:	Reinforced EPDM
Valve Disc:	Elastomer

Pressure — Temperature

Temperature Range:	33°F – 180°F (0.5°C – 82°C)
Maximum Working Pressure:	300psi (21 bar)
Adjustable Reduced Pressure Range:	25 – 75psi (172 – 517kPa)
Standard Reduced Pressure Setting:	50psi (345kPa)

Standards

Meets requirements of ASSE Standard 1003; (ANSI A112.26.2); CSA Standard B356; and listed by IAPMO and City of Los Angeles.



Dimensions – Weights

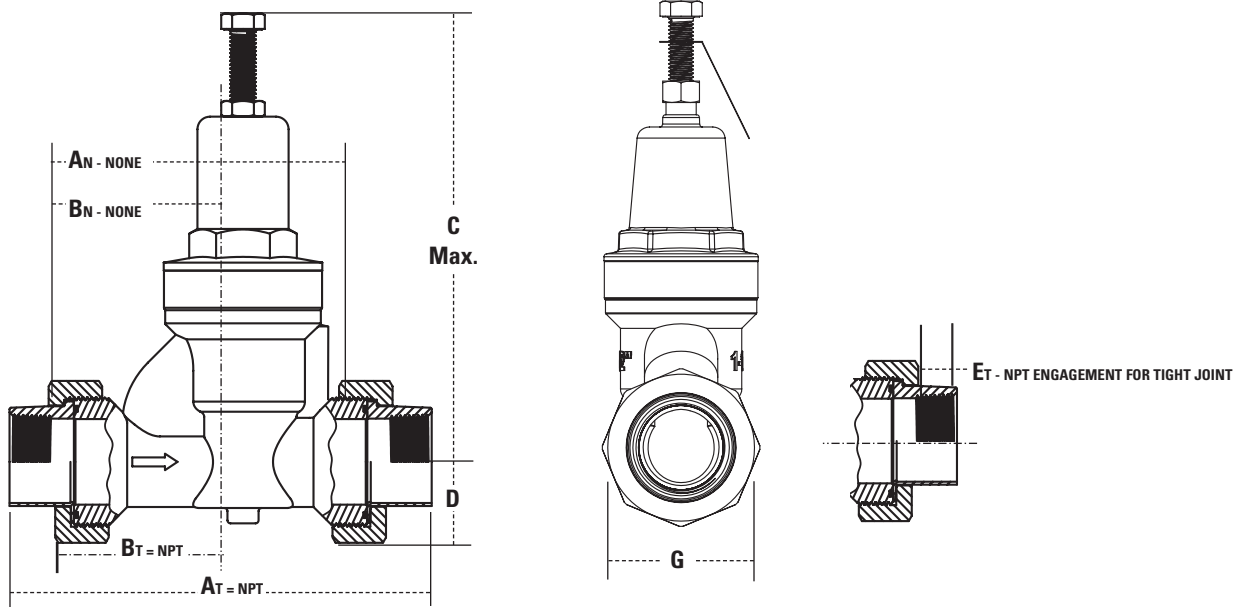

Capacity

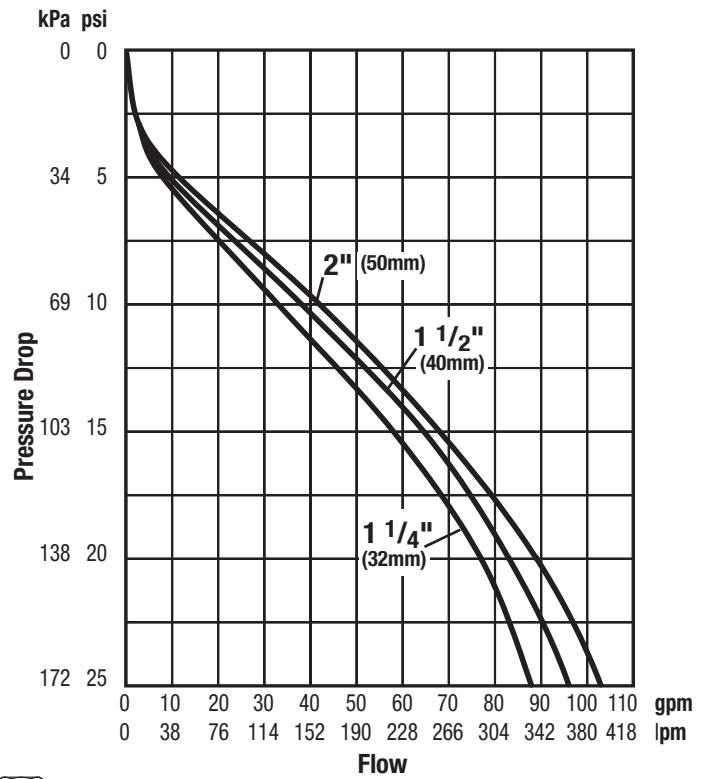

Size: 1 1/2" - 2" (32 - 50mm)

SIZE (DN)		DIMENSIONS										WEIGHTS							
		A _T		A _N		B _T		B _N		C		D		E _T		G			
in.	mm	in.	mm	in.	mm	in.	mm	in.	mm	in.	mm	in.	mm	in.	mm	in.	mm	lbs.	kg
1 1/4	32	8 3/8	213	5 13/16	148	4 3/8	111	3 1/16	78	8 7/8	225	1 7/16	36	1 1/16	27	3 3/4	82	7.5	3.4
1 1/2	40	8 3/8	213	5 13/16	148	4 9/16	115	3 3/4	83	8 7/8	225	1 5/8	41	1 1/16	27	3 3/4	82	9	4.0
2	50	9	228	6 3/8	162	5	126	3 11/16	93	8 7/8	225	1 7/8	47	1 1/16	27	3 11/16	93	10	4.5



A Watts Water Technologies Company



ISO 9001-2000
CERTIFIED

USA: 4381 N. Brawley • Ste. 102 • Fresno, CA • 93722 • Tel. (559) 441-5300 • Fax: (559) 441-5301 • www.FEBCOonline.com
Canada: 5435 North Service Rd. • Burlington, ONT. • L7L 5H7 • Tel. (905) 332-4090 • Fax: (905) 332-7068 • www.FEBCOonline.ca