

Model: 155M

Job Name _____

Contractor _____

Job Location _____

Approval _____

Engineer _____

Contractor's P.O. No. _____

Approval _____

Representative _____

LEAD FREE***Cast Iron Flanged
End Basket Strainers,
Clamped Cover****Model: 155M****Sizes: 2" - 16"**

PRESSURE/TEMPERATURE–NON-SHOCK		
Model	Material	Rating
155M 2" - 12"	Cast Iron	200psi @-20°F to 150°F 13.8 bar @ 65°C
155M 14" - 16"	Cast Iron	150psi @-20°F to 150°F 10.3 bar @ 65°C

Max. temp. can be limited by O-ring material. Consult Factory.

155M**Class 125****Typical Service**

- These are well-suited for high flow applications such as swimming pool installations.
- They are especially suited for medium or coarse straining. For finer straining, see Model 125.
- Model 155M is not recommended for steam service or at temperatures that will allow liquid to flash to steam if the clamp cover is opened. For steam service see Model 165 or other Mueller models with bolted cover.

Features

- The angular cutaway design of the baskets allows a straight through flow, resulting in extremely low pressure drop. See Technical Data section of Mueller Steam Specialty Engineering binder for Pressure Drop Charts.
- Tapped and plugged NPT drain on the strainer bottom at location D. See next page.



Model 155M

Construction

- Cover is secured with quick-opening knobs to minimize service time.

Capacity

- Large capacity basket to capture large amounts of debris and provide maximum time between cleaning.
- Open Area Ratio much greater than pipe size, ensuring low pressure drop.

Galvanizing

- Available on all sizes, consult factory.

Baskets

MODEL	SIZES	LIQUID	
		MATERIAL	OPENING
155M	2" - 4"	304SS	.062 perf
155M	5" and Up	304SS	.125 perf

NOTICE

The information contained herein is not intended to replace the full product installation and safety information available or the experience of a trained product installer. You are required to thoroughly read all installation instructions and product safety information before beginning the installation of this product.

*The wetted surface of this product contacted by consumable water contains less than 0.25% of lead by weight.

Mueller Steam Specialty product specifications in U.S. customary units and metric are approximate and are provided for reference only. For precise measurements, please contact Mueller Steam Specialty Technical Service. Mueller Steam Specialty reserves the right to change or modify product design, construction, specifications, or materials without prior notice and without incurring any obligation to make such changes and modifications on Mueller Steam Specialty products previously or subsequently sold.

A WATTS Brand

Materials

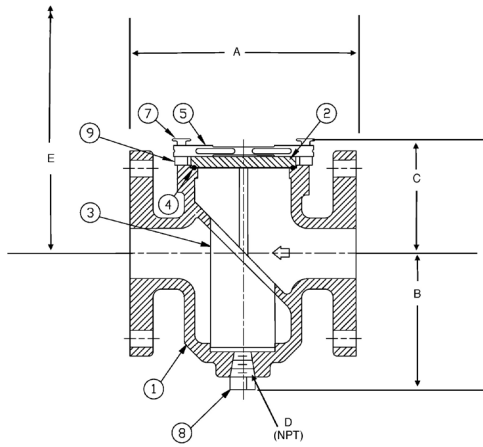

Model 155M

BILL OF MATERIAL MODEL 155M		
ITEM	DESCRIPTION	MATERIAL
1	BODY	Cast Iron ASTM A126-B
2	COVER	ASTM A516-70 Plate
3	BASKET	304 SS
4	COVER GASKET	Buna-N
5	CLAMP	Ductile Iron A536 65-45-12
6	STUDS (not shown)	A193 B16
7	KNOBS	Ductile Iron A536 65-45-12
8	PLUG (not shown)	ASTM A105
9	SPACER	Steel Tubing, ASTM 512

Pressure Drop

See Pressure Drop Charts in Technical Data section of the Mueller Steam Specialty Engineering binder. Cv values are noted in the Dimensions and Weights table below.

Dimensions and Weights

SIZE	DIMENSIONS								WEIGHT		Cv		
	A		B		C		D (NPT)		E SCREEN REMOVAL			lbs.	kgs.
in.	in.	mm	in.	mm	in.	mm	in.	mm	in.	mm			
2	8 ⁹ / ₁₆	219	5 ⁷ / ₁₆	149	5 ³ / ₄	146	1/2	15	10 ⁷ / ₁₆	276	35	15	45
2 ¹ / ₂	7 ⁷ / ₁₆	189	5 ⁵ / ₁₆	137	5 ¹ / ₄	133	3/4	20	9	229	32	14.5	85
3	8 ³ / ₄	222	5 ¹ / ₄	133	6 ⁵ / ₁₆	168	3/4	20	11 ¹ / ₄	286	40	18	140
4	11 ³ / ₁₆	284	8	203	7 ⁷ / ₁₆	187	1	25	15 ¹ / ₂	394	70	31.8	290
5	12 ¹ / ₄	311	10 ¹ / ₄	260	6 ⁹ / ₁₆	167	1	25	14 ¹ / ₄	386	108	49	500
6	14	356	10 ³ / ₁₆	270	8 ⁷ / ₁₆	225	1 ¹ / ₄	32	18 ³ / ₄	464	136	61	800
8	17 ⁷ / ₁₆	435	15 ¹ / ₁₆	384	10	254	1 ¹ / ₂	40	23 ³ / ₁₆	594	218	99	1,600
10	22	559	16	406	12 ³ / ₁₆	321	1 ¹ / ₂	40	29	737	396	180	3,200
12	25 ¹ / ₄	645	23 ¹ / ₁₆	602	14	356	2	50	37 ¹ / ₂	953	720	327	5,000
14	29 ¹ / ₄	756	26 ³ / ₁₆	679	17 ¹ / ₂	445	2	50	42	1066	990	450	7,500
16	31 ⁷ / ₁₆	810	29 ¹ / ₂	749	19	483	2	50	50	1270	1040	472	9,500

Consult Factory for Larger sizes.

Limited Warranty: Mueller Steam Specialty warrants each product to be free from defects in material and workmanship under normal usage for a period of one year from the date of original shipment. In the event of such defects within the warranty period, the Company will, at its option, replace or recondition the product without charge. This shall constitute the sole and exclusive remedy for breach of warranty, and the Company shall not be responsible for any incidental, special or consequential damages, including without limitation, lost profits or the cost of repairing or replacing other property which is damaged if this product does not work properly, other costs resulting from labor charges, delays, vandalism, negligence, fouling caused by foreign material, damage from adverse water conditions, chemical, or any other circumstances over which the Company has no control. This warranty shall be invalidated by any abuse, misuse, misapplication or improper installation of the product. **THIS WARRANTY IS IN LIEU OF ALL OTHER WARRANTIES, EXPRESS OR IMPLIED, INCLUDING ANY IMPLIED WARRANTIES OF MERCHANTABILITY OR FITNESS FOR A PARTICULAR PURPOSE.** Any implied warranties that are imposed by law are limited in duration to one year.

Some States do not allow limitations on how long an implied warranty lasts, and some States do not allow the exclusion or limitation of incidental or consequential damages. Therefore the above limitations may not apply to you. This Limited Warranty gives you specific legal rights, and you may have other rights that vary from State to State. You should consult applicable state laws to determine your rights.



A WATTS Brand

USA: T: (800) 334-6259 • F: (800) 421-6772 • MuellerSteam.com

Latin America: T: (52) 81-1001-8600 • MuellerSteam.com