

Model: 595

UL Listed Cast Iron Flanged Ends Basket Strainers for Firelines Sizes: 4" - 12" (100 - 300mm)

Pressure/Temperature-Non-Shock		
Model	Material	Rating
595	Cast Iron	CWP 175psi @ 150°F 12 bar @ 66°C 125psi @ 406°F

595

Class 125



Model 595

Typical Service

These strainers are used exclusively to prevent clogging in fire service systems. Such systems can include automatic water sprinklers and various spray systems.

Features

- Extra large baskets have an Open Area Ratio of at least 7 to 1. AWWA only requires a minimum of 4 to 1 Ratio.
- Extra large capacity baskets equal very low pressure drop and long intervals between cleaning and servicing, essential in this service.
- NPT tapped blow-off and vent connections are standard. Blow-off is at "D" for draining and cleaning, air vent is at "E". See next page for locations and sizes. Plugs are furnished as standard.

Pressure Drop

SIZE	PRESSURE DROP @ 15 FT/SEC
4"	1.30
6"	2.20
8"	1.14
10"	3.00
12"	3.95

Basket

MODEL	SIZES	STANDARD (WATER)	
		MATERIAL	OPENING
595	4" - 12"	304SS	.250 perf

Material

	595
Body	Cast Iron ASTM A126 Grade B
Cover	Cast Iron ASTM A126 Grade B
Gasket	Compressed Fiber

Job Name _____

Job Location _____

Engineer _____

Approval _____

Contractor _____

Approval _____

Contractor's P.O. No. _____

Representative _____

Dimensions and Weights

SIZE		DIMENSIONS										WEIGHT			
		A		B		C		D (NPT)		E (NPT)		F Screen Removal			
in.	mm	in.	mm	in.	mm	in.	mm	in.	mm	in.	mm	in.	mm	lbs.	kg.
4	100	21	535	7¼	184	10⅝	263	1½	40	¼	8	22	559	237	107
6	150	26⅞	683	8	203	14⅝	371	2	50	¼	8	31½	800	382	173
8	200	31⅝	795	10	254	18⅞	468	2	50	¼	8	39½	1003	654	297
10	250	35¾	908	12	305	20¾	527	2	50	¼	8	44¾	1137	963	437
12	300	40¼	1022	13½	343	25⅜	656	2	50	¼	8	56	1422	1535	697

Apply For Certified Drawings.

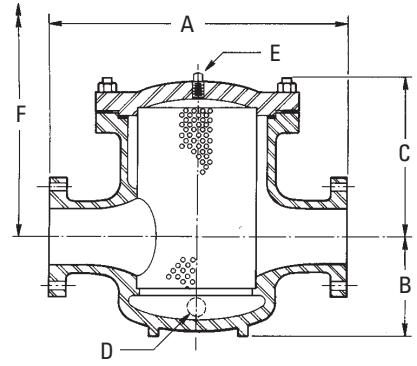

Model 595

Mueller Steam Specialty product specifications in U.S. customary units and metric are approximate and are provided for reference only. For precise measurements, please contact Mueller Steam Specialty Technical Service. Mueller Steam Specialty reserves the right to change or modify product design, construction, specifications, or materials without prior notice and without incurring any obligation to make such changes and modifications on Mueller Steam Specialty products previously or subsequently sold.



A Watts Water Technologies Company



USA: St. Pauls, NC • Tel. 1-800-334-6259 • Fax 1-800-421-6772 • www.muellersteam.com