

# T12 Tank Order - Submittal Sheet

Job Name \_\_\_\_\_

Contractor Signature \_\_\_\_\_

Orion Representative \_\_\_\_\_

Approval Date \_\_\_\_\_

Quantity of Tanks \_\_\_\_\_

Contractor's P.O. No. \_\_\_\_\_

**Please e-mail your signed and completed submittal, tank quote and purchase order to [orientanks@wattswater.com](mailto:orientanks@wattswater.com).**

## T12 Dilution Tank

### Specification

Orion T12 POU 6 USG Dilution Tank shall be cylindrical seamless, stress and defect free, rotationally molded construction to uniform wall thickness from virgin PE resins conforming to ASTM D 1248, with **single side MIP inlet with dip tube, and single MIP outlet as standard**. All penetrations shall be heat fused to tank wall. **Tank cover shall be quick start gasketed lock-down cover.**

Connection Size	
<input type="checkbox"/>	1 1/2"
<input type="checkbox"/>	2"

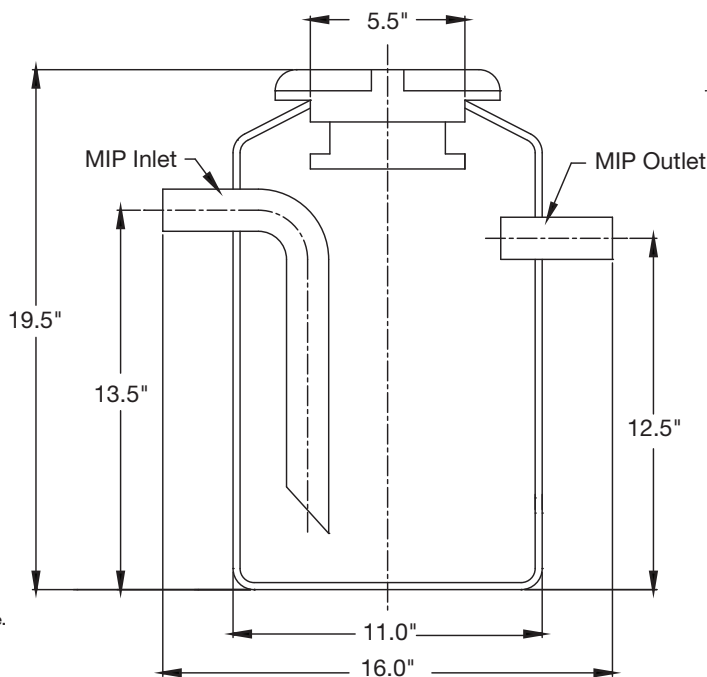
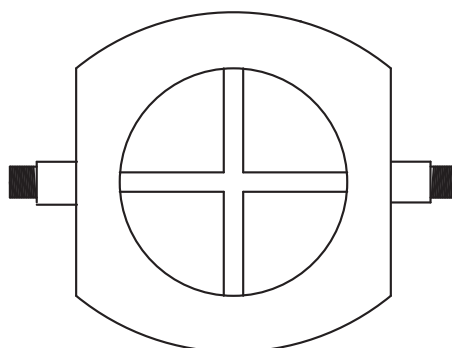

Note: Tanks are made to ±0.25 in. tolerance.

### NOTICE

The information contained herein is not intended to replace the full product installation and safety information available or the experience of a trained product installer. You are required to thoroughly read all installation instructions and product safety information before beginning the installation of this product.

Please verify all selections with your local Orion rep - tank products and accessory equipment are non-returnable.

Orion Fittings product specifications in U.S. customary units and metric are approximate and are provided for reference only. For precise measurements, please contact Orion Fittings Technical Service. Orion Fittings reserves the right to change or modify product design, construction, specifications, or materials without prior notice and without incurring any obligation to make such changes and modifications on Orion Fittings products previously or subsequently sold.



USA: T: (800) 334-6259 • OrionFittings.com  
 Canada: T: (905) 332-4090 • F: (905) 332-7068 • OrionFittings.ca  
 Latin America: T: (52) 81-1001-8600 • OrionFittings.com

**A WATTS Brand**