

For Commercial and Medical Applications

Job Name _____

Contractor _____

Job Location _____

Approval _____

Engineer _____

Contractor's P.O. No. _____

Approval _____

Representative _____

LEAD FREE*

Models OF817-8H, OF817-12H, OF1019-20H and OF1465-75H

OneFlow® Anti-Scale System For Hot Water

Connection Sizes: 1" and 2" (25 and 50mm)

Flow Rates: 2 gpm to 75 gpm (7.6 lpm to 285 lpm)

The OneFlow® Anti-Scale System for hot water provides protection from scale formation on internal and external surfaces where the hot water feed line is being further heated (booster heater) or brought to steam (steam generator, autoclave). The OneFlow® system uses specially designed components to work in applications where the water is heated between 100°F – 150°F (38 - 66°C) but has not yet been treated for scale control. These types of applications typically involve protecting and extending the life of equipment and instruments from the damaging effects of hard water scale.

OneFlow® prevents scale by transforming dissolved hardness minerals into harmless, inactive microscopic crystal particles. These crystals stay suspended in the water and are passed to drain thereby having a greatly reduced ability to react negatively, like dissolved hardness does, particularly in high temperature applications where scale formation is accelerated. The system requires very little maintenance, no backwashing, no salt and no electricity. Typical hardness problems, especially build-up of scale in boilers and steamers are no longer a concern.

OneFlow® is not a water softener. It does not add chemicals or remove any minerals. It is a scale prevention device with proven 3rd party laboratory test data and years of successful Commercial and Medical applications. OneFlow® is the one water treatment device that effectively provides scale protection and is a great alternative to other scale treatment devices.

Features

- Chemical free scale prevention and protection - converts hardness minerals to harmless, inactive microscopic crystals
- Virtually maintenance free - No salt bags or other chemicals to constantly add or maintain
- No control valve, no electricity and no wastewater
- System and components designed to work specifically with hot water applications
- Uses environmentally friendly – “green” technology
- Improves efficiency of all hot water boosting or steam generating equipment
- Simple sizing and installation – all you need to know is pipe size and flow rate
- Built-in bypass valve provides flexibility for off-line service or media replacement
- OneFlow® does not add anything to the water
- Long life media requires replacement once every three years
- Effective retro-fit technology where scale control was not previously considered.



OF817-8H

OF1019-20H

Watts product specifications in U.S. customary units and metric are approximate and are provided for reference only. For precise measurements, please contact Watts Technical Service. Watts reserves the right to change or modify product design, construction, specifications, or materials without prior notice and without incurring any obligation to make such changes and modifications on Watts products previously or subsequently sold.

WATTS®

*The wetted surface of this product contacted by consumable water contains less than one quarter of one percent (0.25%) of lead by weight.

Models

Model	Maximum Flow Rate	Connection Sizes
OF817-8H	8 gpm (30.4 lpm)	1" (25mm) FNPT bypass
OF817-12H	12 gpm (45.6 lpm)	1" (25mm) FNPT bypass
OF1019-20H	20 gpm (76 lpm)	1" (25mm) FNPT bypass
OF1465-75H	75 gpm (285 lpm)	2" (50mm) Socket

Replacement Media Media

OF817-8HRM	Media must be replaced every 3 years
OF817-12HRM	Media must be replaced every 3 years
OF1019-20HRM	Media must be replaced every 3 years
OF1465-75HRM	Media must be replaced every 3 years

Specifications

A OneFlow® scale prevention system for hot water shall be installed on the hot water feed line just prior to the equipment it is intended to protect. The temperature of the hot water feed line should consistently range between 100°F – 150°F (or 38°C – 66°C) as all of the components are designed to work in this elevated temperature condition. The OneFlow® system shall effectively reduce water hardness scale concerns thereby protecting heat-transfer and other surfaces from the negative effects of scale. The system shall be plumbed with a bypass valve to allow isolation of tank(s) and to allow the bypass of untreated hot water in the event that service or media replacement be necessary. The installation area should be suitable in size for the tank(s) to be serviced without encumbrance and for the tank to sit upright on a flat level surface.

The system must not require backwashing, regeneration or any need to discharge water once put into service. The system must not require any chemical additives and must not require electricity for operation. The system must operate in an up-flow manner to minimize any pressure drop.

Standards

DVGW – German Technical and Scientific Association for Gas & Water

OneFlow® meets standard W-512 for testing Physical Water Treatment devices for Scale Prevention and achieved an efficiency rating of 99.6% for scale prevention.

OneFlow® media and components have been tested and certified for material safety to NSF/ANSI Standard 42 & 61.

Dimensions

Model	Dimensions																Weight	
	A		B		C		D		E		F		G		H		lbs.	kgs
	in.	mm	in.	mm	in.	mm	in.	mm	in.	mm	in.	mm	in.	mm	in.	mm		
OF817-8H	20	508	18 ⁵ / ₈	472	8 ¹ / ₂	216	1 ³ / ₈	36	10	254	2	51	6	152	4 ¹ / ₄	108	15	6.8
OF817-12H	20	508	18 ⁵ / ₈	472	8 ¹ / ₂	216	1 ³ / ₈	36	10	254	2	51	6	152	4 ¹ / ₄	108	16	7.3
OF1019-20H	22	559	20 ⁵ / ₈	523	10 ¹ / ₂	267	1 ³ / ₈	36	11	279	2	51	6	152	4 ¹ / ₄	108	26	11.8
OF1465-75H	72	1829	69 ¹ / ₂	1765	17	432	2 ¹ / ₂	64	14	356	2	51	10	254	N/A	N/A	105	47.6

Water Chemistry & Limitations:

pH	6.5 to 8.5
Hardness (max)	75 grains (1300 ppm CaCO ₃)
Temperature	100°F to 150°F (38°C to 66°C)
Chlorine	< 3ppm
Iron	0.3 mg/l
Manganese	0.05 mg/l
Copper	1.3 mg/l
Oil & H ₂ S	none allowed
Polyphosphate	none allowed
Silica (max)	10 ppm

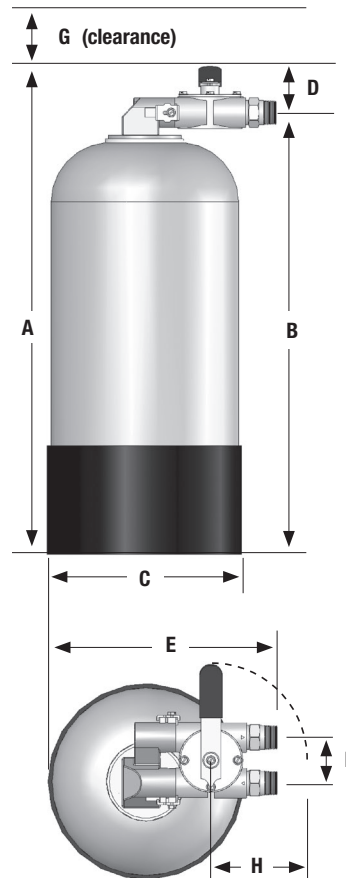

A Watts Water Technologies Company



USA: 815 Chestnut St., No. Andover, MA 01845-6098; www.watts.com

Canada: 5435 North Service Rd., Burlington, ONT. L7L 5H7; www.wattscanada.ca