

For Residential and Commercial Applications

Job Name _____
 Job Location _____
 Engineer _____
 Approval _____

Contractor _____
 Approval _____
 Contractor's P.O. No. _____
 Representative _____

SunTouch® Underfloor®

120 and 240 Voltages

SunTouch UnderFloor is a series resistance heating cable assembled into a foil "radiator" surface. It is installed indoors under a wood subfloor between the joists in residential and light commercial applications. Floor coverings above may be any type, with a maximum of R-11 total insulation for all layers.

Specifications

Supply Voltage	120 VAC, 1-phase 240 VAC, 1-phase
Amp Draw	120 VAC: 1 amp per 10 sf. 240 VAC: 1 amp per 20 sf.
Maximum Circuit Load	20 amps (15 amps with SunStat Control)
Wire Spacing	2-3/4" (70 mm) o.c.
Maximum Allowable Temperature	194°F (90°C) Continuously
EMF	Less than 1 milligauss
Heating Elements	Oxygen-free copper or nickel-copper
Insulation	ETFE Fluoropolymer
Ground Braid	Stainless Steel
Minimum Allowable Bend Radius	1" (25 mm)

Application Parameters			
Watt Density	√	2-3/4" (70 mm) o.c.	10 W/sf
Allowable Floor Coverings		Tile/Stone	
		Carpet	
		Hardwood	

⚠ WARNING

Never cut the heating cable or damage it in any way. Do not install UnderFloor mats in mortar or cement, or install them in the same control zone as HeatWeave mats or WarmWire cables. These products have different heat output, and are manufactured for different applications. Use only the attachment methods as described in the Installation Manual to fasten the UnderFloor as other methods may damage the heating cable.



SunTouch UnderFloor is available in various lengths with voltage options of 120 or 240 VAC.

Installation Guidelines

- Measure and certify the correct wire resistance (ohms) value for the heating cables, record these readings in the chart provided in the installation manual.
- Use of manufacturer's alarm meter (LoudMouth™ meter) is recommended during installation.
- Verify that the area below the subfloor is clear and clean of sharp objects such as nails from above, and is ready to receive work.
- Install the floor sensor in accordance with installation manual.
- Completely unroll the mat to make sure it fits between joists and obstructions.
- Use finish staples to secure the mesh edging to the joists, 2" (51 mm) below the subfloor.



UL Listed for U.S. under UL Standard 1693 and Canada under CAN/CSA C22.2 No. 130.2-93.
 Listing file number E185866.

⚠ CAUTION

This Engineering Sheet is not intended to provide full installation instructions and safety information. In order to avoid property damage or injury, please refer to the complete installation manual and product safety information provided with the product.

SunTouch product specifications in U.S. customary units and metric are approximate and are provided for reference only. For precise measurements, please contact SunTouch Technical Service. SunTouch reserves the right to change or modify product design, construction, specifications, or materials without prior notice and without incurring any obligation to make such changes and modifications on SunTouch products previously or subsequently sold.



SunTouch UnderFloor Application Examples



SunTouch UnderFloor - multiple joist bays

120 VAC UnderFloor

✓	Mat Sizes		
	Order No.	Mat Sizes (W x L)	Amp Draw
	81006826	4' x 16"	0.4
	81006827	6' x 16"	0.7
	81006828	8' x 16"	0.9
	81006829	9'-6" x 16"	1.1
	81006830	12' x 16"	1.3
	81006831	14' x 16"	1.6
	81006832	16' x 16"	1.8
	81006833	18' x 16"	2.0
	81007125	5'-6" x 12"	0.5
	81007126	8' x 12"	0.7
	81007127	10'-6" x 12"	0.9
	81007128	13' x 12"	1.1
	81007129	16' x 12"	1.3

240 VAC UnderFloor

✓	Mat Sizes		
	Order No.	Mat Sizes (W x L)	Amp Draw
	81006835	8' x 16"	0.4
	81006836	12' x 16"	0.7
	81006837	16' x 16"	0.9
	81006838	19'-6" x 16"	1.1
	81007134	10'-6" x 12"	0.4
	81007135	16' x 12"	0.7

⚠ CAUTION

Make sure 120 VAC is supplied to 120 VAC mats and 240 VAC is supplied to 240 VAC mats. Otherwise, dangerous overheating and possible fire hazard can result.

Electrical Wiring Diagram for Single UnderFloor Mat with SunStat Control (120/240 VAC) Dedicated 120 or 240 VAC, 20-amp (maximum) circuit (maximum 15 amp load through SunStat control).

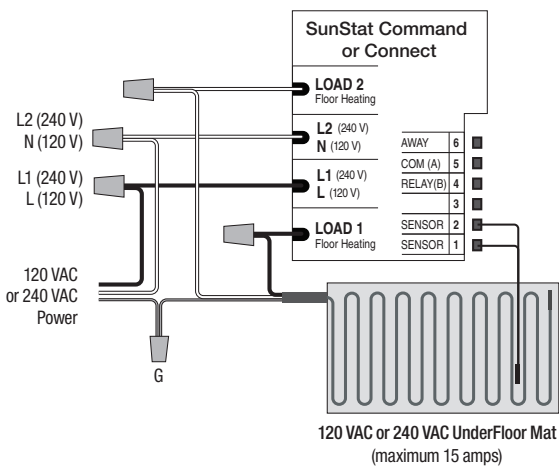

Electrical Wiring Diagram for Multiple UnderFloor Mats with SunStat Control (120/240 VAC) Dedicated 120 or 240 VAC, 20-amp (maximum) circuit (maximum 15 amp load through SunStat control).

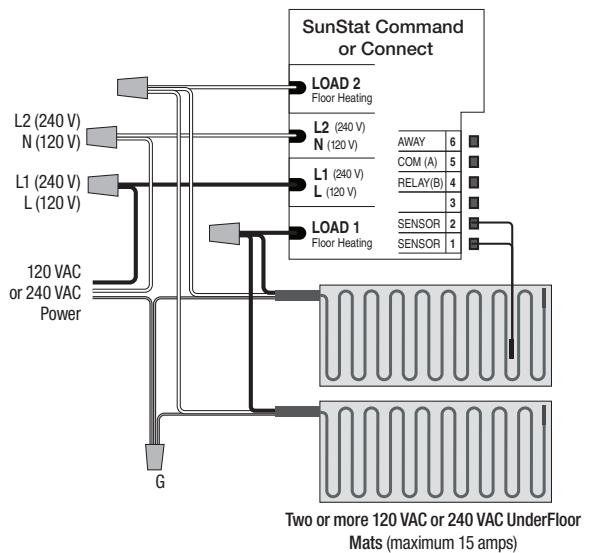

A Watts Water Technologies Company

USA: Tel: (888) 432-8932 • Fax: (417) 831-4067
Canada: Tel: (888) 280-8927 • Fax: (905) 332-7068
Latin America: Tel: (52) 81-1001-8600 • Fax: (52) 81-8000-7091