



CO-200-US

Tag: _____

Floor Cleanout with Square Top, Terrazzo Recess

Components:



SPECIFICATION: Watts Drainage Products CO-200-US epoxy coated cast iron floor cleanout with 5-1/8"(130) square adjustable nickel bronze (standard) top with terrazzo recess, and no hub (MJ) (standard) connection.

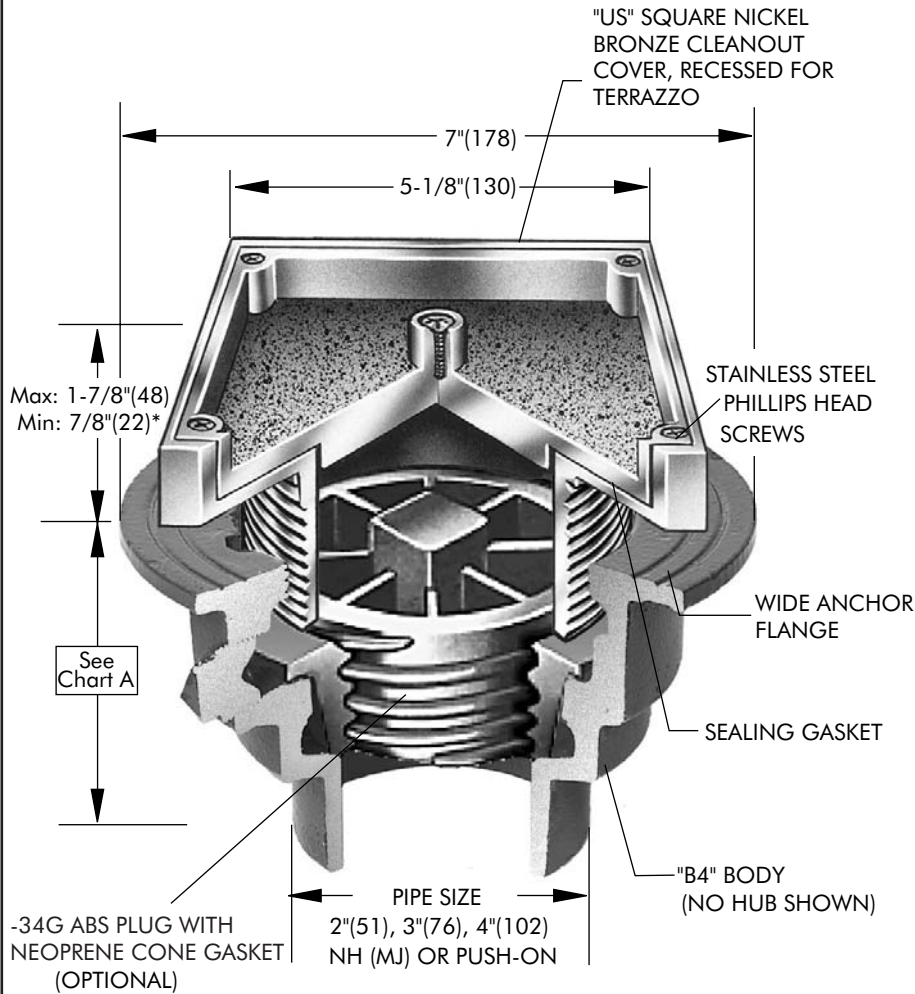

Order Code: CO-20 - - -

Ex. CO-202P-US-3-6

Pipe Sizing (Select One)		
Suffix	Description	
2	2"(51) Pipe Size	<input type="checkbox"/>
3	3"(76) Pipe Size	<input type="checkbox"/>
4	4"(102) Pipe Size	<input type="checkbox"/>

Outlet Type (Select One)		
Suffix	Description	
NH	No Hub (MJ)	<input type="checkbox"/>
P	Push On	<input type="checkbox"/>

Strainer (Select One)		
Suffix	Description	
US-1	5"x5"(127x127), Nickel Bronze	<input type="checkbox"/>
US-3	5"x5"(127x127), Stainless Steel	<input type="checkbox"/>

Options (Select One or More)		
Suffix	Description	
-6	Vandal Proof	<input type="checkbox"/>
-13	Galvanized Body	<input type="checkbox"/>
-15	Strainer Extension (DD-50)	<input type="checkbox"/>
-34G	ABS plug with Neoprene gasket	<input type="checkbox"/>
-113M	Special Epoxy from 3M Range	<input type="checkbox"/>
-C	Membrane Clamp	<input type="checkbox"/>
-Z	Elastomeric Flange	<input type="checkbox"/>

Optional Body Material (NH Only)		
Suffix	Description	
-60	PVC Body w/Socket Outlet	<input type="checkbox"/>
-61	ABS Body w/Socket Outlet	<input type="checkbox"/>

Chart A

	Std.	P	60/61
Pipe Size	No Hub	Push On	PVC/ABS
2"(51)	3"(76)	4"(102)	4"(102)
3"(76)	3"(76)	4"(102)	3-3/4"(95)
4"(102)	3"(76)	4"(102)	3-3/4"(95)

Load Rating

Suffix	Load Rating
US-1	*MD
US-3	*MD

* The load classifications are in accordance with the American National Standards ASME A112.21.1M ASME Ratings are as follows:
MD - Safe Live Load 2000-4999 lbs.(900-2250kg)
The above categories are given as a guide only. Please consult factory.

Job Name _____ Contractor _____

Job Location _____ Contractor's P.O. No. _____

Engineer _____ Representative _____

WATTS Drainage reserves the right to modify or change product design or construction without prior notice and without incurring any obligation to make similar changes and modifications to products previously or subsequently sold. See your WATTS Drainage representative for any clarification. Dimensions are subject to manufacturing tolerances.



CANADA: 5435 North Service Road, Burlington, ON, L7L 5H7 TEL: 905-332-6718 TOLL-FREE: 1-888-208-8927 Website: www.wattsdrainage.ca



© Watts Drainage 2004