



CO-300-MF
Tag: _____

**Extra Heavy Duty
Access Housing**

SPECIFICATION: Watts Drainage Products CO-300-MF epoxy coated cast iron access housing with two fixed anchor flanges and extra heavy duty ductile iron (standard) access cover.

Order Code: **CO-300-** -

Ex. **CO-300-MF-1-6**

Cover (Select One)		
Suffix	Description	
MF-1	Nickel Bronze	<input type="checkbox"/>
MF-3	Stainless Steel Veneer	<input type="checkbox"/>
MF-4	Ductile Iron	<input type="checkbox"/>

Options (Select One or More)		
Suffix	Description	
-6	Vandal Proof	<input type="checkbox"/>
-13	All Galvanized	<input type="checkbox"/>
-85	Special Wording on Top	<input type="checkbox"/>
-113	3M Corrosion Resistant Epoxy	<input type="checkbox"/>

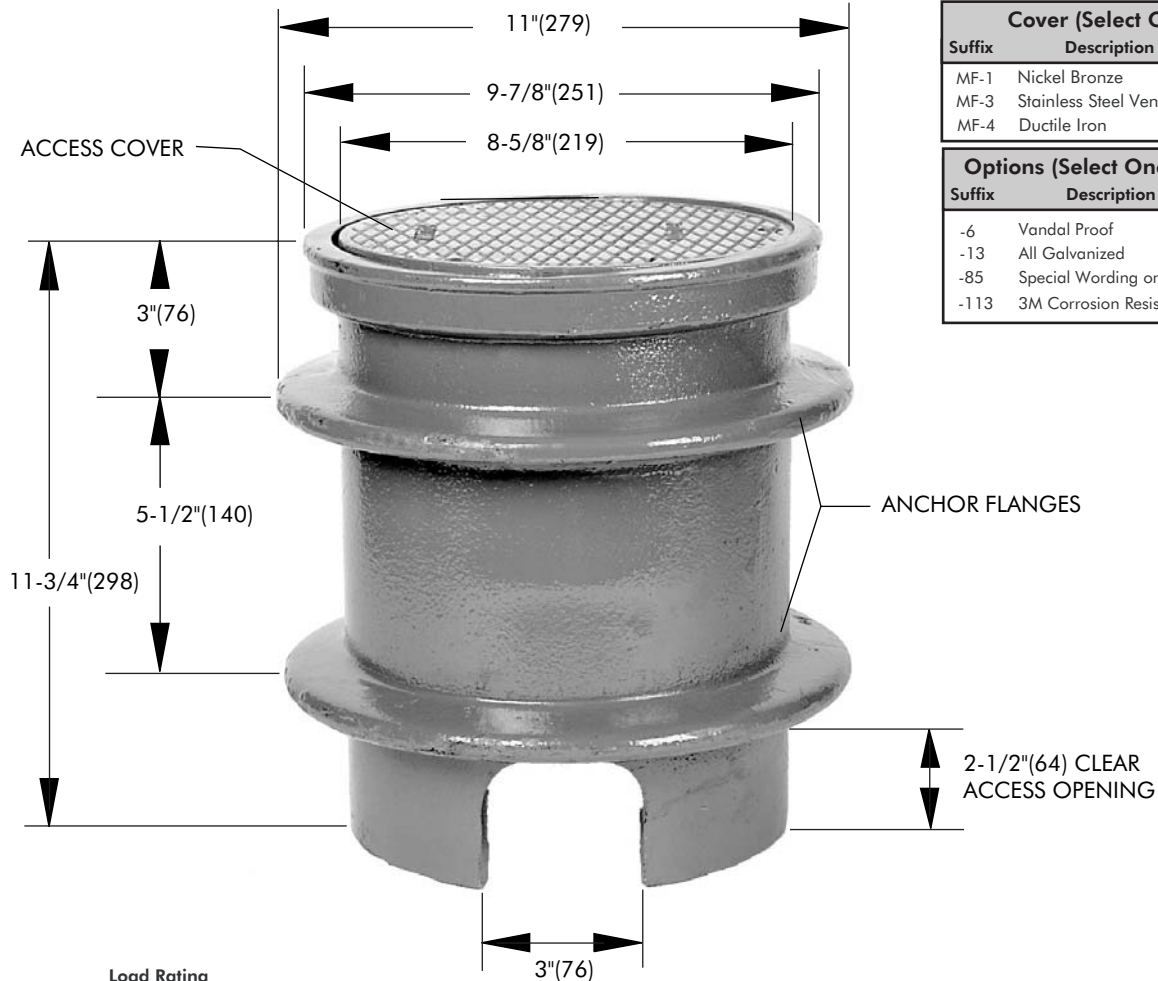

Load Rating	
Suffix	Load Rating
MF-1	*XHD
MF-3	*XHD
MF-4	*XHD

* The load classifications are in accordance with the American National Standards ASME A112.21.1M ASME Ratings are as follows:
XHD - Safe Live Load 7500-10000 lbs.(3375-4500kg)
The above categories are given as a guide only.
Please consult factory.

**Note: If Cleanout is required use
WATTS CO-200**

Job Name _____ Contractor _____

Job Location _____ Contractor's P.O. No. _____

Engineer _____ Representative _____

WATTS Drainage reserves the right to modify or change product design or construction without prior notice and without incurring any obligation to make similar changes and modifications to products previously or subsequently sold. See your WATTS Drainage representative for any clarification. Dimensions are subject to manufacturing tolerances.



CANADA: 5435 North Service Road, Burlington, ON, L7L 5H7 TEL: 905-332-6718 TOLL-FREE: 1-888-208-8927 Website: www.wattsdrainage.ca

