

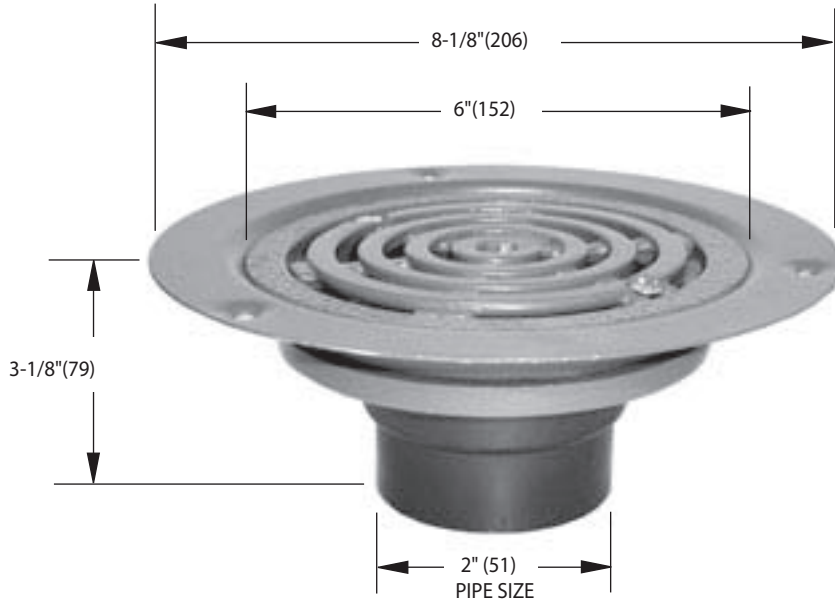

Tag: **FD-370**

Wood Deck Drain w/Surface Membrane Clamp

SPECIFICATION: Watts Drainage Products FD-370 epoxy coated wood deck drain with 5"(127) diameter heel proof aluminum grate and surface membrane clamp, recessed securing flange, and 2"(51) ABS socket outlet.



Options (Select One or More)		
Suffix	Description	
-6	Vandal Proof	<input type="checkbox"/>

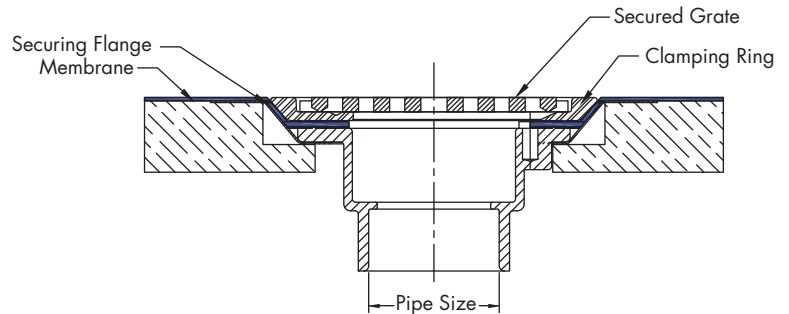

Typical Installation

NOTICE

Load Rating & Free Area

Load Rating	Free Area Sq. In.
*LD	8

The load classifications are in accordance with the American National Standards ASME A112.21.1M ASME Ratings are as follows:
 LD - Safe Live Load 7500-10000 lbs.(3375-4500kg)
 The above categories are given as a guide only. Please consult factory.

Job Name _____

Contractor _____

Job Location _____

Contractor's P.O. No. _____

Engineer _____

Representative _____

Watts product specifications in U.S. customary units and metric are approximate and are provided for reference only. For precise measurements, please contact Watts Technical Service. Watts reserves the right to change or modify product design, construction, specifications, or materials without prior notice and without incurring any obligation to make such changes and modifications on Watts products previously or subsequently sold.



A Watts Water Technologies Company

USA: Tel: (800) 338-2581 • Fax: (828) 248-3929 • Watts.com
Canada: Tel: (905) 332-4090 • Fax: (905) 332-7068 • Watts.ca
Latin America: Tel: (52) 81-1001-8600 • Fax: (52) 81-8000-7091 • Watts.com