



FD-870-PA

Tag: _____

Large Free Area Planting Area Drain

Components:

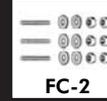

SPECIFICATION: Watts Drainage Products FD-870-PA planting area drain with epoxy coated all cast iron body and membrane clamping device and large self-locking epoxy coated cast aluminum (standard) dome strainer with mesh screen.

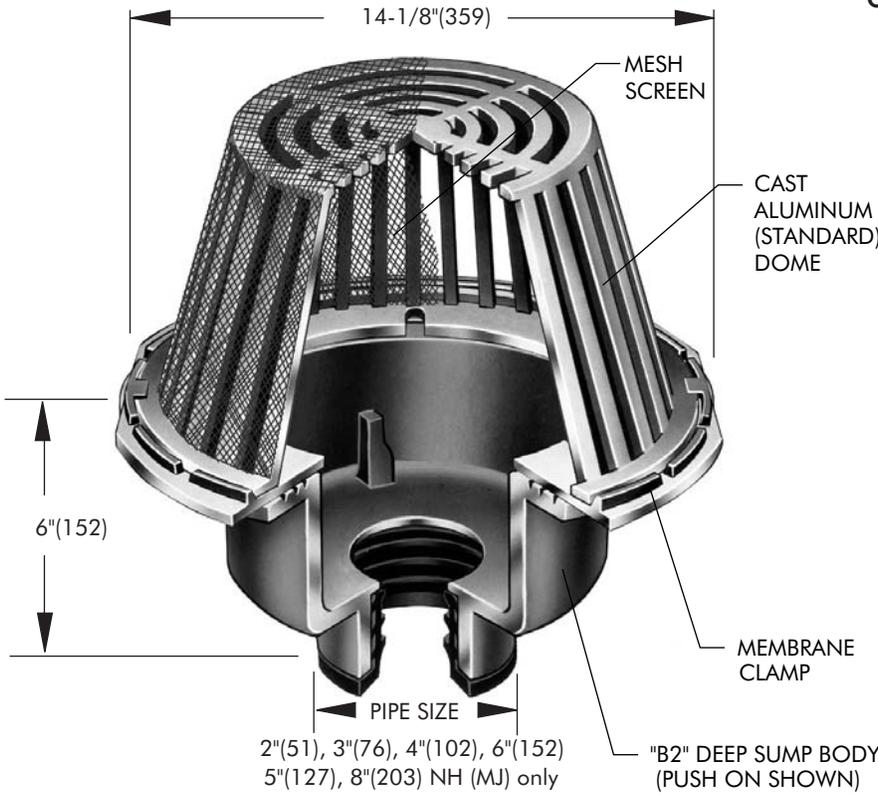

Free Area Sq. In.
136

Order Code: FD-87 -PA-

Ex. FD-872P-PA

Pipe Sizing (Select One)		
Suffix	Description	
2	2"(51) Pipe Size	<input type="checkbox"/>
3	3"(76) Pipe Size	<input type="checkbox"/>
4	4"(102) Pipe Size	<input type="checkbox"/>
5	5"(127) Pipe Size	<input type="checkbox"/>
6	6"(152) Pipe Size	<input type="checkbox"/>
8	8"(203) Pipe Size	<input type="checkbox"/>

Outlet Type (Select One)		
Suffix	Description	
NH	No Hub (MJ)	<input type="checkbox"/>
P	Push On	<input type="checkbox"/>
T	Threaded Outlet	<input type="checkbox"/>
X	Inside Caulk	<input type="checkbox"/>

Options (Select One or More)		
Suffix	Description	
-B	Sump Receiver	<input type="checkbox"/>
-D	Underdeck Clamp	<input type="checkbox"/>
-SO	Side Outlet	<input type="checkbox"/>
-6	Vandal Proof	<input type="checkbox"/>
-10	Secured Top c/w Phillips Screws	<input type="checkbox"/>
-13	Galvanized Body and Clamp	<input type="checkbox"/>
-81	Bronze Dome	<input type="checkbox"/>

Optional Body Material (NH Only)		
Suffix	Description	
-60	PVC Body w/Socket Outlet	<input type="checkbox"/>
-61	ABS Body w/Socket Outlet	<input type="checkbox"/>

Job Name _____ Contractor _____

Job Location _____ Contractor's P.O. No. _____

Engineer _____ Representative _____

WATTS Drainage reserves the right to modify or change product design or construction without prior notice and without incurring any obligation to make similar changes and modifications to products previously or subsequently sold. See your WATTS Drainage representative for any clarification. Dimensions are subject to manufacturing tolerances.



CANADA: 5435 North Service Road, Burlington, ON, L7L 5H7 TEL: 905-332-6718 TOLL-FREE: 1-888-208-8927 Website: www.wattsdrainage.ca

