



**FD-930**

Tag: \_\_\_\_\_

**Parking Deck Drain for Precast Slabs**

**SPECIFICATION:** Watts Drainage FD-930 epoxy coated cast iron parking deck drain with integral countersunk deck flange, 15-5/8" (397) square top with secured ductile iron heel proof grate, gasket seal between body and top assembly, and no hub (standard) outlet.

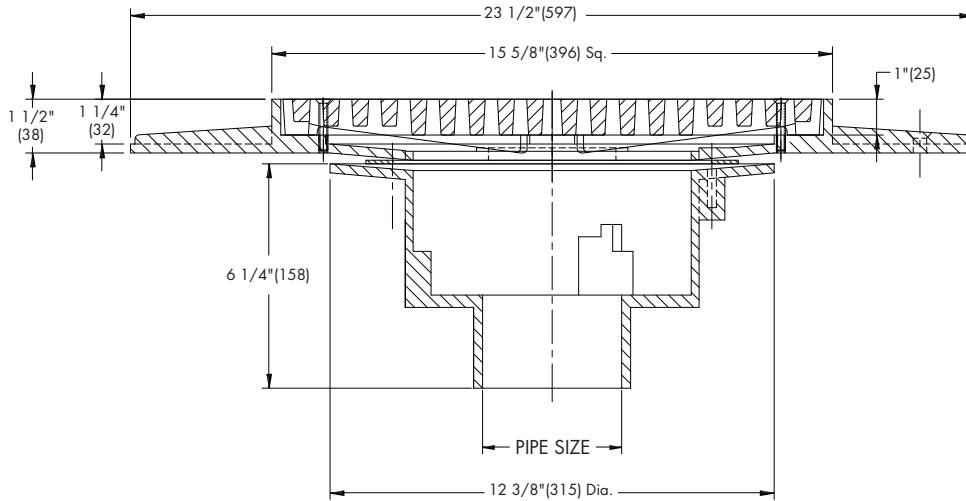

Pipe Sizing (Select One)		
Suffix	Description	
2	2"(51) Pipe Size	<input type="checkbox"/>
3	3"(76) Pipe Size	<input type="checkbox"/>
4	4"(102) Pipe Size	<input type="checkbox"/>
5	5"(127) Pipe Size (NH Only)	<input type="checkbox"/>
6	6"(152) Pipe Size	<input type="checkbox"/>
8	8"(203) Pipe Size (NH Only)	<input type="checkbox"/>

Outlet Type (Select One)		
Suffix	Description	
NH	No Hub (MJ)	<input type="checkbox"/>
P	Push On	<input type="checkbox"/>
T	Threaded Outlet	<input type="checkbox"/>
X	Inside Caulk	<input type="checkbox"/>

Options (Select One or More)		
Suffix	Description	
-5	Sediment Bucket	<input type="checkbox"/>
-6	Vandal Proof	<input type="checkbox"/>
-13	All Galvanized	<input type="checkbox"/>
-D	Underdeck Clamp	<input type="checkbox"/>
-SB	Shallow Body 2-3/4" Deep (3", 4", 6", NH/P, 8" NH)	<input type="checkbox"/>
-US	Buy American Compliant	<input type="checkbox"/>

Load Rating	Free Area Sq. In.
*XHD	79

**NOTICE**

The load classifications are in accordance with the American National Standards ASME A112.21.1M ASME Ratings are as follows:  
 XHD - Safe Live Load 7500-10000 lbs.(3375-4500kg)  
 The above categories are given as a guide only.  
 Please consult factory.

**NOTICE**

The information contained herein is not intended to replace the full product installation and safety information available or the experience of a trained product installer. You are required to thoroughly read all installation instructions and product safety information before beginning the installation of this product.

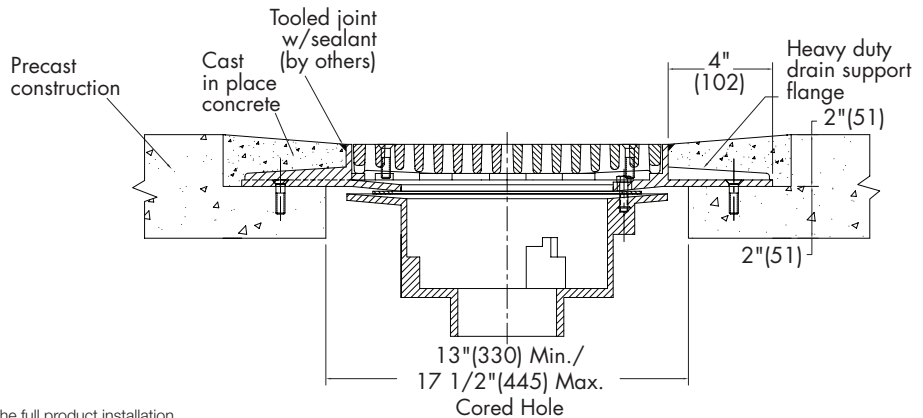

Job Name \_\_\_\_\_

Contractor \_\_\_\_\_

Job Location \_\_\_\_\_

Contractor's P.O. No. \_\_\_\_\_

Engineer \_\_\_\_\_

Representative \_\_\_\_\_

Watts product specifications in U.S. customary units and metric are approximate and are provided for reference only. For precise measurements, please contact Watts Technical Service. Watts reserves the right to change or modify product design, construction, specifications, or materials without prior notice and without incurring any obligation to make such changes and modifications on Watts products previously or subsequently sold.



**USA:** Tel: (800) 338-2581 • Fax: (828) 248-3929 • Watts.com  
**Canada:** Tel: (905) 332-4090 • Fax: (905) 332-7068 • Watts.ca  
**Latin America:** Tel: (52) 81-1001-8600 • Fax: (52) 81-8000-7091 • Watts.com