



RD-100-F

Tag: _____

Roof Drain with Deck Flange/Adj. Extension

SPECIFICATION: Watts Drainage RD-100-F epoxy coated cast iron roof drain with flashing clamp with integral gravel stop, heavy guage zinc plated steel deck flange with adjustable extension, self-locking polyethylene dome (standard), and no hub (standard) outlet.

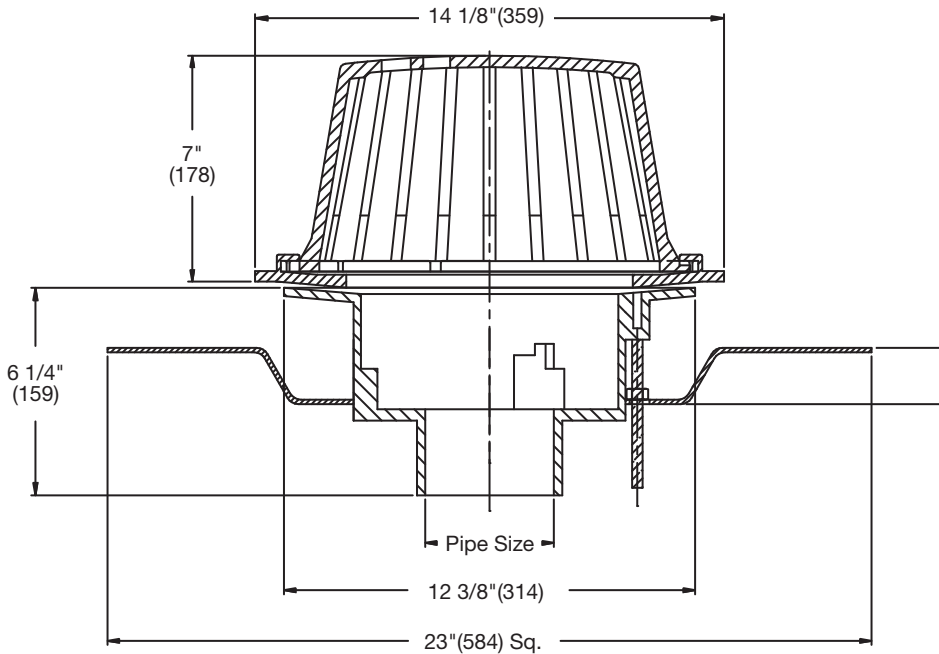

Pipe Sizing (Select One)		
Suffix	Description	
2	2"(51) Pipe Size	<input type="checkbox"/>
3	3"(76) Pipe Size	<input type="checkbox"/>
4	4"(102) Pipe Size	<input type="checkbox"/>
5	5"(127) Pipe Size	<input type="checkbox"/>
6	6"(152) Pipe Size	<input type="checkbox"/>

Outlet Type (Select One)		
Suffix	Description	
NH	No Hub (MJ)	<input type="checkbox"/>
P	Push On	<input type="checkbox"/>
T	Threaded Outlet	<input type="checkbox"/>
X	Inside Caulk	<input type="checkbox"/>

Options (Select One or More)		
Suffix	Description	
-13	Galvanized Body & Flashing Clamp	<input type="checkbox"/>
-A	Accutrol Flow Restrictor	<input type="checkbox"/>
-D	Underdeck Clamp	<input type="checkbox"/>
-GSS	Stainless Steel Ballast Guard	<input type="checkbox"/>
-K	Ductile Iron Dome	<input type="checkbox"/>
-K13	Galvanized Dome	<input type="checkbox"/>
-K40	Ductile Iron Low Dome (4"high)	<input type="checkbox"/>
-K80	Aluminum Dome	<input type="checkbox"/>
-K81	Rough Bronze Dome	<input type="checkbox"/>
-K83	SS Mesh Covered Dome	<input type="checkbox"/>
-L	Vandal Proof Dome	<input type="checkbox"/>
-R	2" External Water Dam	<input type="checkbox"/>
-SO	Side Outlet 2,3,4" Only	<input type="checkbox"/>
-US	Buy American Compliant	<input type="checkbox"/>
-W	Adjustable Internal Water Dam	<input type="checkbox"/>

Optional Body Material		
Suffix	Description	
60	PVC Body w/Socket Outlet	<input type="checkbox"/>
61	ABS Body w/Socket Outlet	<input type="checkbox"/>

NOTICE

The information contained herein is not intended to replace the full product installation and safety information available or the experience of a trained product installer. You are required to thoroughly read all installation instructions and product safety information before beginning the installation of this product

Free Area
Sq. In.

137

Recommended Deck Opening 14"(356)

Job Name _____

Contractor _____

Job Location _____

Contractor's P.O. No. _____

Engineer _____

Representative _____

Watts product specifications in U.S. customary units and metric are approximate and are provided for reference only. For precise measurements, please contact Watts Technical Service. Watts reserves the right to change or modify product design, construction, specifications, or materials without prior notice and without incurring any obligation to make such changes and modifications on Watts products previously or subsequently sold.



USA: Tel: (800) 338-2581 • Fax: (828) 248-3929 • Watts.com

Canada: Tel: (905) 332-4090 • Fax: (905) 332-7068 • Watts.ca

Latin America: Tel: (52) 81-1001-8600 • Fax: (52) 81-8000-7091 • Watts.com