

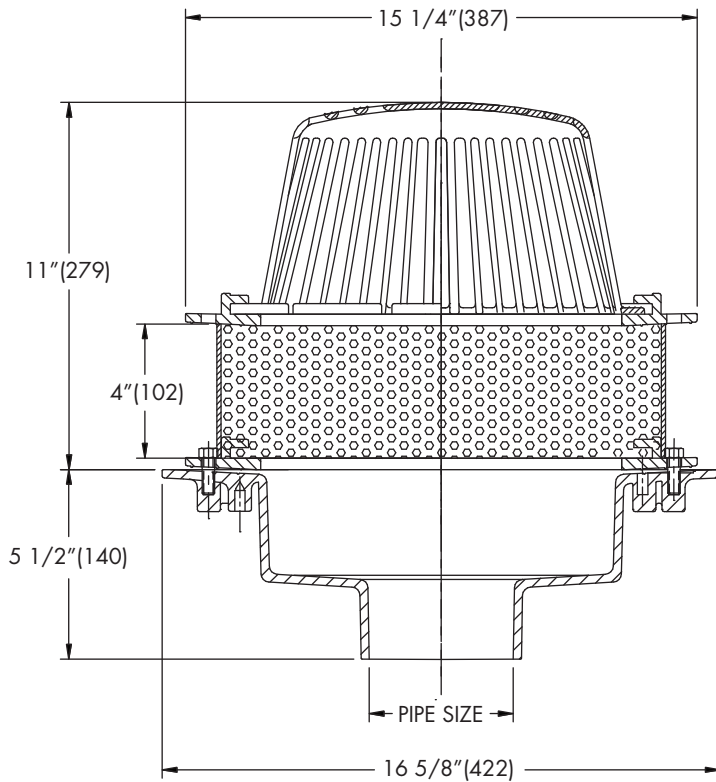

Tag: **RD-300-85**

IRMA Roof Drain

SPECIFICATION: Watts Drainage RD-300-85 epoxy coated cast iron roof drain with flashing clamp, 4"(102) stainless steel perforated extension, self-locking polyethylene dome (standard), and no hub (standard) outlet.



Pipe Sizing (Select One)	
Suffix	Description
2	2"(51) Pipe Size (NH Only) <input type="checkbox"/>
3	3"(76) Pipe Size <input type="checkbox"/>
4	4"(102) Pipe Size <input type="checkbox"/>
5	5"(127) Pipe Size (NH Only) <input type="checkbox"/>
6	6"(152) Pipe Size <input type="checkbox"/>
8	8"(203) Pipe Size <input type="checkbox"/>
10	10"(254) Pipe Size (NH Only) <input type="checkbox"/>

Outlet Type (Select One)	
Suffix	Description
NH	No Hub (MJ) <input type="checkbox"/>
P	Push On <input type="checkbox"/>
X	Inside Caulk <input type="checkbox"/>

Options (Select One or More)	
Suffix	Description
-13	Galvanized Body and Clamp <input type="checkbox"/>
-B	Sump Receiver <input type="checkbox"/>
-D	Underdeck Clamp <input type="checkbox"/>
-F	Deck Flange/Adj. Extension <input type="checkbox"/>
-GSS	Stainless Steel Ballast Guard <input type="checkbox"/>
-K	Ductile Iron Dome <input type="checkbox"/>
-K13	Galvanized Dome <input type="checkbox"/>
-K40	Ductile Iron Low Dome (4" high) <input type="checkbox"/>
-K80	Aluminum Dome <input type="checkbox"/>
-K81	Rough Bronze Dome <input type="checkbox"/>
-K83	SS Mesh Covered Dome <input type="checkbox"/>
-L	Vandal Proof Dome <input type="checkbox"/>
-R	2" External Water Dam <input type="checkbox"/>
-US	Buy American Compliant <input type="checkbox"/>
-W	Adjustable Internal Water Dam <input type="checkbox"/>

Free Area Sq. In.
137

**Deck opening 14-1/2" (368)
with sump receiver 18" (457)**

Job Name _____ Contractor _____
 Job Location _____ Contractor's P.O. No. _____
 Engineer _____ Representative _____

Watts product specifications in U.S. customary units and metric are approximate and are provided for reference only. For precise measurements, please contact Watts Technical Service. Watts reserves the right to change or modify product design, construction, specifications, or materials without prior notice and without incurring any obligation to make such changes and modifications on Watts products previously or subsequently sold.

USA: Tel: (800) 338-2581 • Fax: (828) 248-3929 • Watts.com
Canada: Tel: (905) 332-4090 • Fax: (905) 332-7068 • Watts.ca
Latin America: Tel: (52) 81-1001-8600 • Fax: (52) 81-8000-7091 • Watts.com

