



WD-A Series

Tag: _____

Semi-Automatic Draw-Off Grease Interceptor

SPECIFICATION: Watts Drainage WD-AH Series recessed epoxy coated steel semi-automatic draw-off grease interceptor with gasketed epoxy coated steel cover, hex head perimeter bolts, removable grease accumulating cover and baffle assembly, deep seal trap with cleanout, internal stainless steel flow control plate, flexible draw-off hose, outlet line shut-off valve, IPS threaded connections, and epoxy coated steel access housing with skid-proof cover and adjustable carrier brackets.

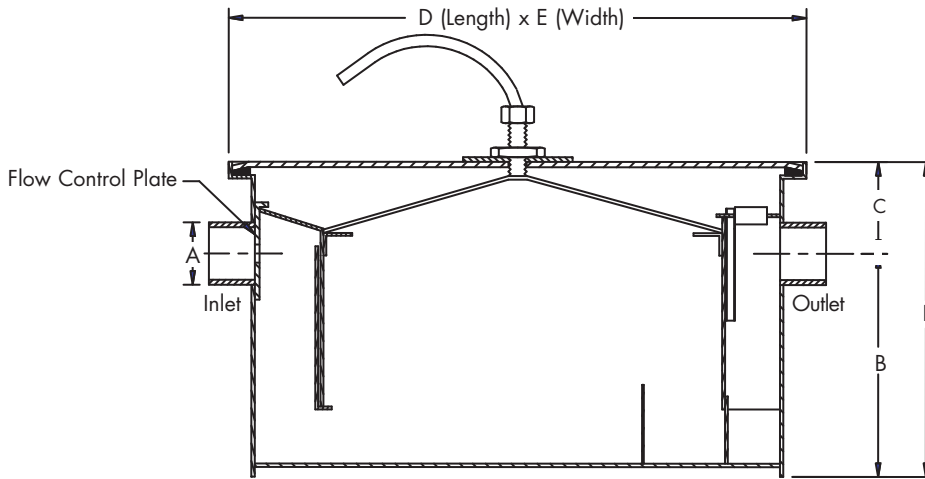

Flow Rate (Select One)		
Suffix	Description	
7	7 GPM	<input type="checkbox"/>
10	10 GPM	<input type="checkbox"/>
15	15 GPM	<input type="checkbox"/>
20	20 GPM	<input type="checkbox"/>
25	25 GPM	<input type="checkbox"/>
35	35 GPM	<input type="checkbox"/>
50	50 GPM	<input type="checkbox"/>
75	75 GPM	<input type="checkbox"/>

Options (Select One)		
Suffix	Description	
-O	Inlet & Outlet other than Standard Size	<input type="checkbox"/>
-SS	Stainless Steel	<input type="checkbox"/>

Interceptor Catalog Number	Flow Rate GPM	Grease Capacity Lbs.	A Inlet & Outlet	B Base To Center	C Top To Center	D Length	E Width	F Height
WD-7-A	7	14	2"(51)	8-1/2"(216)	3-1/2"(89)	18"(457)	13"(330)	12"(305)
WD-10-A	10	20	2"(51)	8-1/2"(216)	3-1/2"(89)	21-3/4"(552)	14"(356)	12"(305)
WD-15-A	15	30	2"(51)	10-1/2"(267)	3-1/2"(89)	22"(559)	15"(381)	14"(356)
WD-20-A	20	40	3"(76)	11-1/2"(292)	3-1/2"(89)	24"(610)	15-3/4"(400)	15"(381)
WD-25-A	25	50	3"(76)	12"(305)	4-1/2"(114)	26"(660)	16-1/2"(419)	16-1/2"(419)
WD-35-A	35	70	3"(76)	14"(356)	5"(127)	30"(762)	18"(457)	19"(483)
WD-50-A	50	100	4"(102)	16"(406)	5-1/2"(140)	32"(813)	22"(559)	21-1/2"(546)
WD-75-A	75	150	4"(102)	18-1/2"(470)	5-1/2"(140)	36"(914)	24"(610)	24"(610)

NOTICE

The information contained herein is not intended to replace the full product installation and safety information available or the experience of a trained product installer. You are required to thoroughly read all installation instructions and product safety information before beginning the installation of this product.

Job Name _____

Contractor _____

Job Location _____

Contractor's P.O. No. _____

Engineer _____

Representative _____

Watts product specifications in U.S. customary units and metric are approximate and are provided for reference only. For precise measurements, please contact Watts Technical Service. Watts reserves the right to change or modify product design, construction, specifications, or materials without prior notice and without incurring any obligation to make such changes and modifications on Watts products previously or subsequently sold.



USA: Tel: (800) 338-2581 • Fax: (828) 248-3929 • Watts.com
Canada: Tel: (905) 332-4090 • Fax: (905) 332-7068 • Watts.ca
Latin America: Tel: (52) 81-1001-8600 • Fax: (52) 81-8000-7091 • Watts.com