

For Commercial Applications

Job Name _____

Contractor _____

Job Location _____

Approval _____

Engineer _____

Contractor's P.O. No. _____

Approval _____

Representative _____

Series PWS30, PWS30-2, PWS30-P

Commercial Water Softening Systems

Connection Size: 3" (80mm)

Flow Rates: Up to 1120 gpm (4239 lpm)

Watts Pure Water Series PWS30, PWS30-2, PWS30-P water softening systems are highly efficient conventional cation exchange type water softeners. They are suitable for commercial applications ranging from 300,000 to 1,050,000 grains of hardness removal per tank and flow rates up to 1120 gpm (4239 lpm). Where continuous softened water is required PWS30-2 duplex alternating and PWS30-P systems can be specified for uninterrupted service. Regeneration is meter demand initiated. All cycles of regeneration are fully automatic and do not require manual actuation.

Watts Pure Water Series PWS30, PWS30-2, PWS30-P water softeners are designed for point of use or point of entry applications where the benefits of softened water are required. These systems exchange scale-forming calcium and magnesium ions with non scale-forming sodium ions to create soft water for a variety of applications.

Steam boiler make up water, water heater pretreatment, reverse osmosis pretreatment, cooling tower make up water, sterilizer make up water, washing, and process water are all common applications for the Watts Pure Water Series PWS30, PWS30-2 and PWS30-P water softeners. Watts Pure Water Series PWS30-P are ideal for commercial and industrial applications where high flow and high capacities are required to accommodate wide variances in flow rates.

Softened water provides a wide variety of benefits such as preventing lime scale formation in pipes, valves, water heating equipment, heat exchangers, and cooling towers to reducing mineral build up in areas that see excessive splashing such as food preparation counters and sink areas. Softened water also conserves soaps and cleaning agents by eliminating the formation of soap curd, so your cleaners can work on cleaning – not reacting with the hardness in your water.

Standards

Control Valve- Certified to NSF/ANSI Std. 61 and 372

Ion Exchange Resin- Certified to NSF/ANSI Std. 61

Mineral Tank- Certified to NSF/ANSI Std. 44 or 61

Specifications

A Watts Pure Water Series PWS30, PWS30-2, PWS30-P water softening system shall be installed on the building's main water line just after it enters the building. The installation point shall be after any backflow prevention or pressure regulating valves. Other installation options are to install a system just before the water heater or other types of equipment needing the protection of softened water. In installations where dedicated cold water make up to a water heater is the installation point, a backflow preventer and a thermal expansion tank must be installed as well. The system shall be installed with a bypass valve to allow for the shut down and removal of the unit without interrupting the water supply to the building.

Watts product specifications in U.S. customary units and metric are approximate and are provided for reference only. For precise measurements, please contact Watts Technical Service. Watts reserves the right to change or modify product design, construction, specifications, or materials without prior notice and without incurring any obligation to make such changes and modifications on Watts products previously or subsequently sold.

WATTS
pure water



Series PWS30

Series PWS30-2



Series PWS30-P

The water softener shall be a down flow regenerated, metered demand, sodium cycle cation exchange type system with all components necessary for proper operation.

NOTICE

Electrical requirements are 120 volt 60 hertz. A local drain is required to accept drain water from the system. The feed water pressure must not fall below 25psi or exceed 125psi. Water temperature must not fall below 34°F or exceed 110°F (1°C - 43°C). The system shall provide softened water measuring less than one grain per gallon of hardness as Calcium Carbonate when operated within the manufacturer's operational specifications.

WATTS

Features

- Durable brass bodied control valve for years of service
- Fully automatic metered demand control valve certified to NSF/ANSI standards
- Sophisticated digital electronic controls that store operating history that can be accessed by the user
- Fully adjustable regeneration cycles
- Dry contact lock out switch for remote interface is standard
- High capacity resin certified to NSF/ANSI standards
- Highly corrosion resistant fiberglass tanks certified to NSF/ANSI standards
- Durable polypropylene lower distribution system

PWS30-P Features

- Easily select duplex, triplex or quadplex system with flow demand staging
- Model for capacities up to 1,050,000 grains per tank
- Arrange up to 4 tanks in parallel for flow rates up to 1120 GPM
- All systems have no hard water bypass pistons
- Each system is complete with brine tank and meter
- All systems have Fleck brass in-line flow meters

Feed Water Guidelines

pH	6 to 10
Hardness (maximum)	Depends on customers acceptable hardness leakage level.
Water Pressure	25psi to 125psi (171kPa to 8.5 bar)
Temperature	34 - 110°F (1 - 43°C)
Free Chlorine (maximum)	1mg/L
Iron (maximum)	1mg/L
Oil and H ₂ S	None Allowed
Turbidity	Less than 5.0 NTU

For all other guideline information please contact your Watts representative.

Note: Do not use with water that is microbiologically unsafe or of unknown quality without adequate disinfection before or after the system.

Dimensions - Weights

PWS30 & PWS30-P

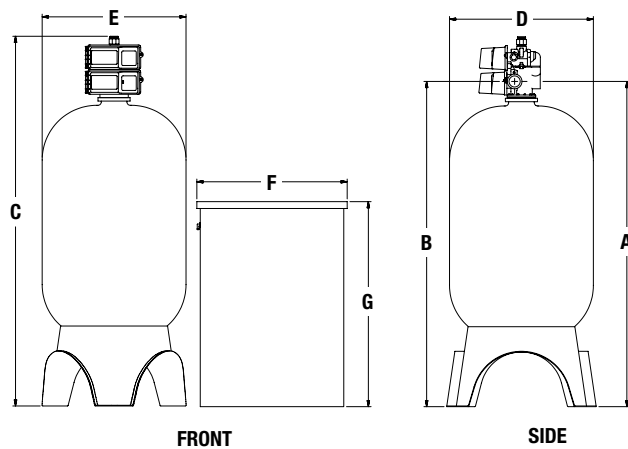

PWS30-2

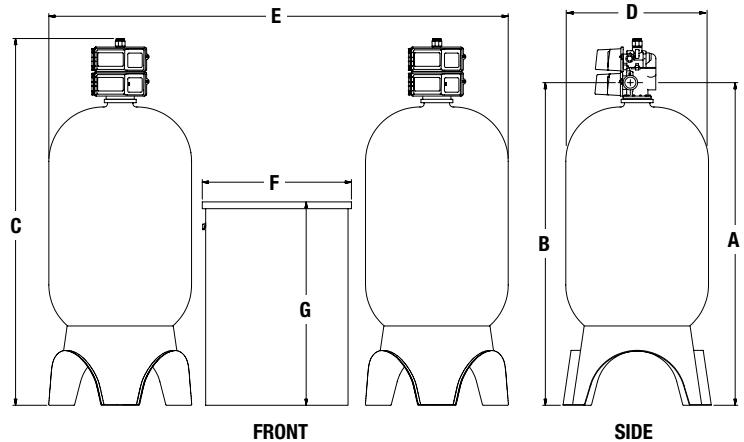

NOTICE

Dimensional data is for a single mineral tank system ONLY. PWS30-P models are composed of multiple PWS30 systems See Space Required in table below.

Series PWS30 & PWS30-P

MODEL NO.	DIMENSIONS												WEIGHT lbs		
	A		B		C		D		E		F			G	
	in.	mm	in.	mm	in.	mm	in.	mm	in.	mm	in.	mm	in.	mm	
PWS30151H11	79 ⁷ / ₁₆	2017	79 ⁷ / ₁₆	2017	95 ¹ / ₄	2419	24 ¹ / ₂	622	24 ¹ / ₈	613	30	762	50	1270	1070
PWS30151I11	81 ⁷ / ₁₆	2068	81 ⁷ / ₁₆	2068	96 ³ / ₄	2457	30 ¹ / ₈	765	30 ¹ / ₈	765	39	991	48	1219	1600
PWS30151J11	87 ¹ / ₄	2216	87 ¹ / ₄	2216	101	2565	36 ¹ / ₈	917	36 ¹ / ₈	917	39	991	60	1524	2015
PWS30151K11	95 ¹ / ₄	2419	95 ¹ / ₄	2419	108	2743	44	1118	44	1118	42	1067	60	1524	3245
PWS30151L11	99 ⁵ / ₈	2530	99 ⁵ / ₈	2530	112 ³ / ₈	2854	50 ³ / ₈	1280	50 ³ / ₈	1280	50	1270	60	1524	4295

Series PWS30-2

MODEL NO.	DIMENSIONS												WEIGHT lbs		
	A		B		C		D		E		F			G	
	in.	mm	in.	mm	in.	mm	in.	mm	in.	mm	in.	mm	in.	mm	
PWS30151H21	79 ⁷ / ₁₆	2017	79 ⁷ / ₁₆	2017	95 ¹ / ₄	2419	24 ¹ / ₂	622	85	2159	30	762	50	1270	2070
PWS30151I21	81 ⁷ / ₁₆	2068	81 ⁷ / ₁₆	2068	96 ³ / ₄	2457	30 ¹ / ₈	765	100	2540	39	991	48	1219	3000
PWS30151J21	87 ¹ / ₄	2216	87 ¹ / ₄	2216	101	2565	36 ¹ / ₈	917	111	2819	39	991	60	1524	4015
PWS30151K21	95 ¹ / ₄	2419	95 ¹ / ₄	2419	108	2743	44	1118	126	3200	42	1067	60	1524	6245
PWS30151L21	99 ⁵ / ₈	2530	99 ⁵ / ₈	2530	112 ³ / ₈	2854	50 ³ / ₈	1280	150	3810	50	1270	60	1524	8295

NOTICE

Service gpm is for a single mineral tank system ONLY. For PWS30-P Series systems, you will need to multiply the Service gpm by (x2) for Duplex, (x3) for Triplex and (x4) for Quadplex systems.

Specifications

MODEL NO.	MINERAL TANK			BRINE TANK		SOFTENING CAPACITY		LBS. SALT PER REGENERATION		FLOW RATE & PRESSURE		
	TANK SIZE	RESIN FT ³	GRAVEL	TANK SIZE	SALT FILL	MAX	MIN	MAX	MIN	SERV GPM	DROP PSI	BKW GPM
PWS30151H11	24" x 72"	10	200 lbs.	30" x 50"	1400	300 K	200 K	150	60	120/170	15/25	15
PWS30151I11	30" x 72"	15	400 lbs.	39" x 48"	2200	450 K	300 K	225	90	158/212	15/25	25
PWS30151J11	36" x 72"	20	500 lbs.	39" x 60"	2700	600 K	400 K	300	120	185/250	15/25	35
PWS30151K11	42" x 72"	30	700 lbs.	42" x 60"	3100	900 K	600 K	450	180	200/268	15/25	45
PWS30151L11	48" x 72"	35	900 lbs.	50" x 60"	4500	1050K	700 K	525	210	213/280	15/25	60

Ordering Information

MODEL NO.	DESCRIPTION	SPACE REQUIRED DXWXH	WEIGHT LBS
PWS30151H11	10 Cubic Foot 3" Simplex Softener with Flow Meter	39" x 69" x 103"	1070
PWS30151I11	15 Cubic Foot 3" Simplex Softener with Flow Meter	39" x 75" x 107"	1600
PWS30151J11	20 Cubic Foot 3" Simplex Softener with Flow Meter	39" x 81" x 109"	2015
PWS30151K11	30 Cubic Foot 3" Simplex Softener with Flow Meter	42" x 90" x 117"	3245
PWS30151L11	35 Cubic Foot 3" Simplex Softener with Flow Meter	50" x 104" x 117"	4295
PWS30151H21	10 Cubic Foot 3" Duplex Alternating Softener with Flow Meter	39" x 100" x 103"	2070
PWS30151I21	15 Cubic Foot 3" Duplex Alternating Softener with Flow Meter	39" x 117" x 107"	3000
PWS30151J21	20 Cubic Foot 3" Duplex Alternating Softener with Flow Meter	39" x 129" x 109"	4015
PWS30151K21	30 Cubic Foot 3" Duplex Alternating Softener with Flow Meter	42" x 144" x 117"	6245
PWS30151L21	35 Cubic Foot 3" Duplex Alternating Softener with Flow Meter	50" x 164" x 117"	8295

Ordering Information for 3" Duplex Progressive Softeners

MODEL NO.	ORDERING CODE	DESCRIPTION	SPACE REQUIRED D X W X H	WEIGHT LBS
PWS30151H22	7100651	10 Cubic Foot 3" Progressive Duplex Softener with Flow Meters	59" x 72" x 106"	2140
PWS30151I22	7100652	15 Cubic Foot 3" Progressive Duplex Softener with Flow Meters	74" x 90" x 107"	3200
PWS30151J22	7100653	20 Cubic Foot 3" Progressive Duplex Softener with Flow Meters	80" x 90" x 111"	4030
PWS30151K22	7100654	30 Cubic Foot 3" Progressive Duplex Softener with Flow Meters	90" x 100" x 118"	6490
PWS30151L22	7100655	35 Cubic Foot 3" Progressive Duplex Softener with Flow Meters	106" x 114" x 123"	8590

Ordering Information for 3" Triplex Progressive Softeners

MODEL NO.	ORDERING CODE	DESCRIPTION	SPACE REQUIRED D X W X H	WEIGHT LBS
PWS30151H33	7100656	10 Cubic Foot 3" Progressive Triplex Softener with Flow Meters	59" x 108" x 106"	3210
PWS30151I33	7100657	15 Cubic Foot 3" Progressive Triplex Softener with Flow Meters	74" x 135" x 107"	4800
PWS30151J33	7100658	20 Cubic Foot 3" Progressive Triplex Softener with Flow Meters	80" x 135" x 111"	6045
PWS30151K33	7100659	30 Cubic Foot 3" Progressive Triplex Softener with Flow Meters	90" x 150" x 118"	9735
PWS30151L33	7100660	35 Cubic Foot 3" Progressive Triplex Softener with Flow Meters	106" x 171" x 123"	12885

Ordering Information for 3" Quadplex Progressive Softeners

MODEL NO.	ORDERING CODE	DESCRIPTION	SPACE REQUIRED D X W X H	WEIGHT LBS
PWS30151H44	7100757	10 Cubic Foot 3" Progressive Quadplex Softener with Flow Meters	59" x 144" x 106"	4280
PWS30151I44	7100758	15 Cubic Foot 3" Progressive Quadplex Softener with Flow Meters	74" x 180" x 107"	6400
PWS30151J44	7100759	20 Cubic Foot 3" Progressive Quadplex Softener with Flow Meters	80" x 180" x 111"	8060
PWS30151K44	7100760	30 Cubic Foot 3" Progressive Quadplex Softener with Flow Meters	90" x 200" x 118"	12980
PWS30151L44	7100761	35 Cubic Foot 3" Progressive Quadplex Softener with Flow Meters	106" x 228" x 123"	17180

Notes: Capacities are based on resin manufacturer's data and are dependent upon influent water TDS, temperature, bed depth, and flow rates. Feed water must be free of oil and color. Pipe size, tank size, and space requirements are in inches. Capacities and flow rates expressed above are per tank. Flow rates listed at 25psi drops are for intermittent peak flow rates and are not to be used as continuous flows.

NOTICE

The information contained herein is not intended to replace the full product installation and safety information available or the experience of a trained product installer. You are required to thoroughly read all installation instructions and product safety information before beginning the installation of this product.



USA: T: (800) 224-1299 • F: (978) 794-1848 • Watts.com/PureWater
Canada: T: (905) 332-4090 • F: (905) 332-7068 • Watts.ca/PureWater
Latin America: T: (52) 81-1001-8600 • Watts.com/PureWater