



WATTS SILVER EAGLE®

Series 757

757

Double Check
Valve Assemblies

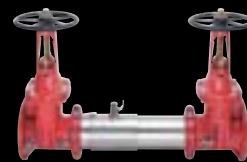

757DCDA

Double Check
Detector Assemblies



Superior Backflow Protection from Watts

When it comes to protecting the health and safety of people, why choose anything but the best? The Series 757 SilverEagle® backflow prevention assemblies incorporate the latest design features to protect against con-

tamination at non-health hazard cross-connections. The SilverEagle series is the most compact, the lightest and offers the most flexibility of any backflow assembly in the industry. Specify the valve with safety at its core!

757/757DCDA Features

- Closest competitor is more than 360% heavier
- Most compact design in the industry
- Entire valve body and closure sleeve manufactured from 300 Series Stainless Steel
- Approved with gate valves or UL/FM butterfly valves
- Approved for horizontal, vertical or "N" pattern installations
- Utilizes groove connections for ease of installation & pipe alignment
- Patented tri-link check module allows ease of serviceability
- Smallest enclosure footprint
- Replaceable check disc rubber
- Available with quarter-turn ball valve shutoffs (2½" - 3")



757/757DCDA

Lay Length

Compare 4" Double Check With Shutoff Valves

Backflow Assembly	Laylength (in)	% Longer Than Watts
Watts 757	31.9	
FEBCO 850 W/OS&Y - GPC 5/01	46.2	58%
Wilkins 350 W/OS&Y - BF 350	37.7	29%

Typical Fire Flow Rates – 15 FPS

2½"	224 GPM	6"	1350 GPM
3"	350 GPM	8"	2400 GPM
4"	500 GPM	10"	3700 GPM

Assembly Weight

Compare 4" Double Check With Shutoff Valves

Backflow Assembly	Weight (lbs)	% Heavier Than Watts
Watts 757	61	
FEBCO 850 W/OS&Y - GPC 5/01	312	411%
Wilkins 350 W/OS&Y - BF 350	281	360%

Certified Flow Characteristics

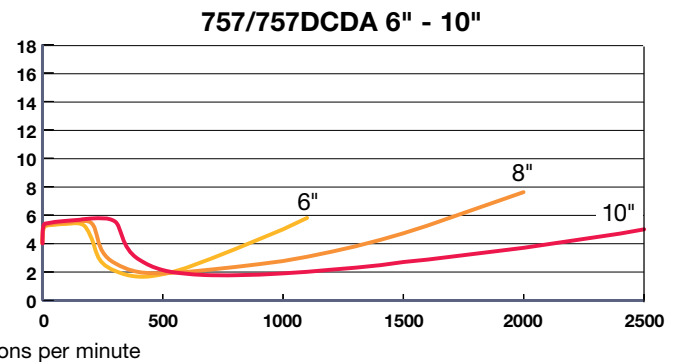
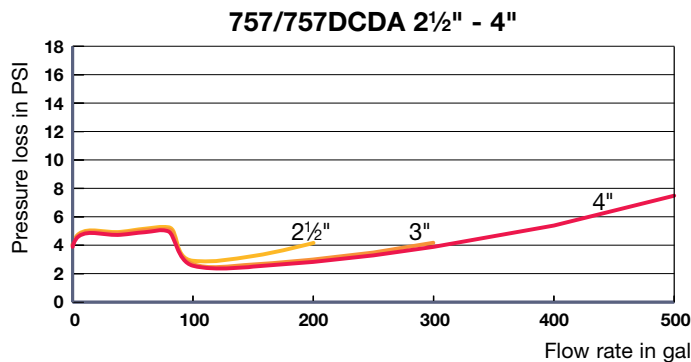

Dimensions & Weight

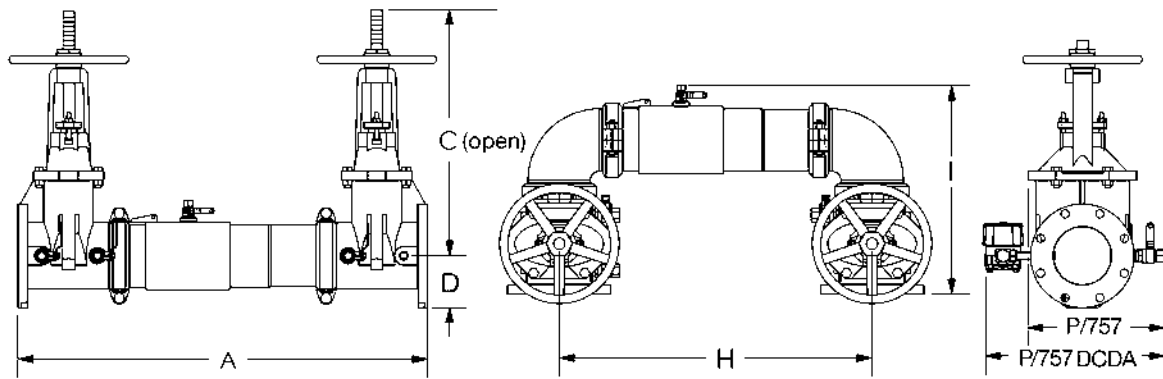

With OSY Gate Valves

With UL/FM Butterfly Valves

Size	A	C	D	H	I	P		*Weight (lbs.)		A	C	D	H	I	P		*Weight (lbs.)	
						DC	DCDA	DC	DCDA						DC	DCDA	DC	DCDA
2½"	31"	16⅞"	3½"	22"	15½"	9⅞"	13⅞"	125	139	28"	8"	3½"	22"	14⅝"	9"	13"	56	70
3"	31⅞"	18⅞"	3⅞"	22¾"	17⅞"	10½"	14½"	145	159	28½"	8⅞"	3⅞"	22¾"	15⅞"	9½"	13½"	54	68
4"	33⅞"	22¾"	4"	24"	18½"	11⅞"	15⅞"	161	175	29⅞"	8⅝"	3⅞"	24"	16¼"	10"	14"	61	75
6"	43½"	30⅞"	5½"	33¾"	23⅞"	15"	19"	295	309	36½"	10"	5"	33¾"	19⅞"	10½"	14½"	117	131
8"	50"	37¾"	6⅞"	40⅝"	27⅞"	17⅞"	21⅞"	480	494	43"	12¼"	6½"	40⅝"	23⅞"	14⅞"	18⅞"	261	275
10"	57½"	45¾"	8⅞"	50"	32½"	20"	24"	781	795									

*For "N" pattern weights consult ES-757/757N

UL/FM Butterfly Valves or Quarter-Turn Ball Valves Available



Advantages of UL/FM Butterfly Valves

- Butterfly valves have built-in tamper switch wiring
- Backflow assembly is lighter & more compact
- Groove couplings allow ease of installation & pipe alignment
- All butterfly valves display flow indicator flag

Advantages of Quarter-Turn Ball Valves

- Positive drip tight closure
- Fast quarter-turn operation
- Available 2½" – 3" sizes
- Available for "N" pattern horizontal installations
- Low operating torque



Cutaway View — Full Flow Operation

Normal Operation

In normal flowing operation, the independent torsion spring check remains closed until there is a water demand. Each check will then open and maintain an approximate 1psi differential in the direction of flow. In a nonflow or backflow condition, both checks will close until the resumption of normal flow.

Applications — 757

Double Check Valve Assemblies are used to prevent backflow of pollutants that are objectionable but not toxic. Double Check Valve Assemblies may be installed under continuous pressure service and may be subject to backpressure.

Double Check Valve Assemblies may be used in fire protection systems without chemical additives, industrial in-plant plumbing systems and other systems requiring non-health hazard protection. Local codes may vary, consult authorities for specific approved applications.

Applications — 757DCDA

Double Check Detector Assemblies are used to prevent backflow of pollutants that are objectionable, but not toxic. Double Check Detector Assemblies may be installed under continuous pressure service and may be subject to backpressure.

The Double Check Detector Assembly is used primarily on fireline sprinkler systems when it is necessary to monitor unauthorized use of water.

Approvals

Contact the factory

Specifications

The Double Check Valve Assembly shall consist of two independent torsion spring check modules within a single housing with sleeve access, required test cocks and drip tight shutoff valves. Torsion spring checks may be removed and reinstalled in housing without any special tools. The housing shall be constructed of 300 Series stainless steel with groove end connections. Torsion spring checks shall have reversible elastomer discs and in operation shall produce drip tight closure against reverse flow caused by backpressure or backsiphonage. Assembly shall be a Watts 757 or 757DCDA.

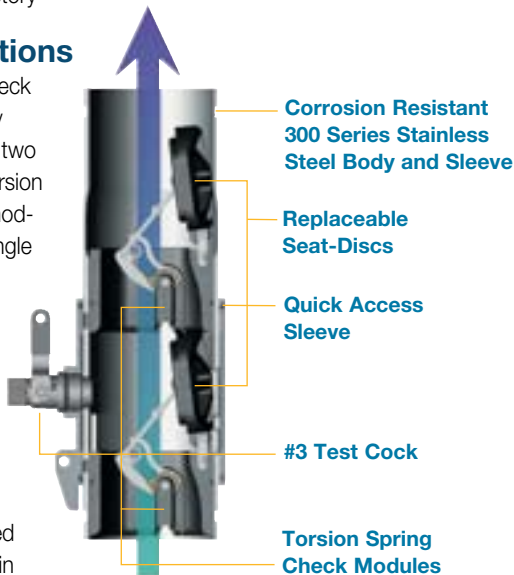

Patent # 6,443,181 and 6,478,047



A Watts Water Technologies Company

Installation Guidelines

Most field problems occur because dirt or debris present in the system at the time of installation becomes trapped in the 1st check seating area resulting in a low or zero differential across the 1st check. **The system should be flushed before the backflow valve is installed.** If the system is not flushed until after the backflow assembly is installed, remove both check modules from the valve and open the inlet shutoff to allow water to flow for a sufficient time to flush debris from the water line. If debris in the water system continues to cause fouling, a strainer should be installed upstream of the backflow assembly.

Series 757 and 757DCDA may be installed in either a **horizontal, vertical, or "N" position** as long as the backflow assembly is installed in accordance with the direction of the flow arrow on the assembly and the local water authority approves the installation.

The assembly should be installed with adequate clearance around the valve to allow for inspection, testing, and servicing. Twelve inches should be the minimum clearance between the lower portion of the assembly and the floor or grade.

757/757DCDA Interior Installation

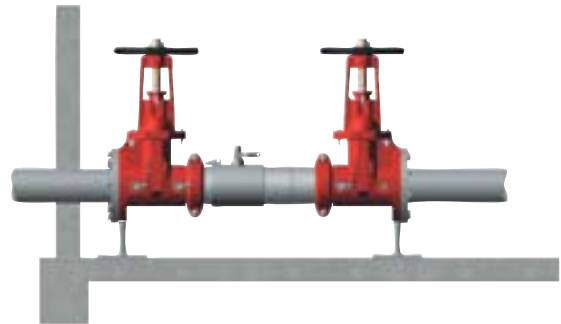

Enclosure Installation

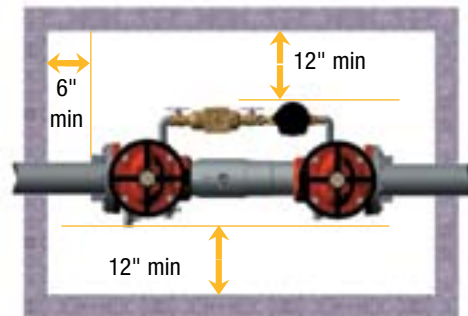

Characteristics and Materials

Rated Working Pressure	Hydrostatic Test Pressure
175psi	350psi
Temperature Range	Body Construction
33°F – 110°F	300 Series Stainless Steel

End Connection

Groove per AWWA C-606 (IPS) or Flange per ANSI B16.1, Class 125

2½" – 3" available with threaded QT ball valve shutoffs (757 Series)



USA: No. Andover, MA • Tel: (978) 688-1811 • Fax: (978) 794-1848 • www.watts.com
Canada: Burlington, ON • Tel: (905) 332-4090 • Fax: (905) 332-7068 • www.wattscanada.ca