

# MTOL+™ Online & M100+™ Laboratory Turbidimeter Systems

The MTOL+™ Online Turbidimeter has been specifically designed for measuring the NTU of filtered water, re-use water, raw water and many industrial applications. The MTOL+ features built-in Ultrasonic auto-cleaning and data logging as well as easy set-up, maintenance, and calibration. Calibration is completed using ProCal™ EPA approved\* NTU calibration standards.

The MTOL+ is compatible with the M100+ laboratory turbidimeter which offers a color touchscreen display and sample data logging for multiple sample ID's. The M100+ also stores calibration NTU values and the date/time of calibration.

The two units share calibration standards eliminating the need for different calibration standards between laboratory and process NTU.

## On-site User Selectable Range

MTOL+ Ranges include: 0 - 10, 0 - 100, 0 - 1000 NTU

## MTOL+ Standard Features

- Meets USEPA Method 180.1 or ISO 7027 design and performance criteria
- Ranges 0 - 10 NTU, 0 - 100 NTU or 0 - 1000 NTU (User-Selectable - Factory Set to 0 - 100 NTU)
- Small footprint - Takes up very little space
- Local Display/User Interface provided with each instrument
  - Fast response time and inexpensive calibration low sample volume (30 ml)
  - Modular design reduces overall costs - Replace electronics without stopping flow
  - Removable sample cuvettes allow for easy cleaning and calibrating
  - Ultrasonic Cleaning Function
  - Optics are not in contact with the sample - reduces chance of false low readings
  - Convenient reusable EPA Approved primary calibration standards
    - USE WITH BOTH Online & Lab units
    - Same Standard set for both versions for most applications



**MTOL+**  
**Online Process Turbidimeter**  
Factory default 0 - 100 NTU



**M100+**  
**Laboratory Turbidimeter**

\*ProCal NTU Standards are EPA approved for use as primary NTU standards

## Model MTOL+ Turbidimeter System

The continuous monitoring NTU system shall include the online model with power supply, display, user interface and sensor as one single SKU. It will not be necessary to purchase a separate module for display or power supply. The turbidimeter shall meet all requirements specified by the USEPA Method 180.1 (White Light Model), ISO 7027 (Infrared Model) and Standard Methods 2130B. The turbidimeter shall be Modbus compatible and have a 4-20 mA output. The turbidimeter shall have the same optical design as the M100+ laboratory turbidimeter.

The online turbidimeter shall have an ultrasonic auto-clean system. Accuracy shall be 2% of reading or plus or minus 0.02, whichever is greater, from 0-40 NTU, and 5% of reading or plus or minus 0.02, whichever is greater, from 40-1000 NTU. Resolution will be 0.001 NTU (user selectable).

The sensor shall utilize a rotational flow through assembly with a 30ml measuring cuvette. The specially designed flow head bubble rejection system will reduce the need for a bubble trap and provide a faster response time. The sample stream will remain under pressure, ensuring it will not be exposed to open atmosphere, which can cause precipitants in some circumstances. Precipitation of oxidized sample constituents can result in false NTU readings. The sensor shall allow grab samples to be measured without the need to stop sample flow to the flow head.

Calibration and standardization will be accomplished using small volumes (30ml) of reusable primary standards. Primary Standards shall be reusable for multiple online turbidimeters and also with the M100+ laboratory turbidimeter. Calibration procedures can be completed without disrupting the sample flow. Details of calibration (date and time of last successful calibration) will be stored on the analyzer. An integral part of the turbidimeter system is the inclusion of a laboratory instrument specifically designed to use the same calibration standards. The required supporting laboratory instrument must be an HF scientific M100+ touchscreen model with USB data logging and ability to store the date/time of the last calibration.

The process turbidimeter and the laboratory turbidimeter lamp source and detector shall not come in contact with the sample, eliminating false low readings. The turbidimeters shall use menu driven software. The online turbidimeter enclosure shall be ABS. The online turbidimeter will have data logging features, will store the latest date/time of calibration and be user selectable for ranges of 0 – 10 NTU, 0 – 100 NTU (factory default) or 0 – 1000 NTU. The online turbidimeter shall be HF scientific MTOL+ Online Turbidimeter.

## MTOL+ Features & Benefits:

### Optical design

The unique, shared optical design allows consistent readings between the M100+ laboratory turbidimeter and the MTOL+. The unique optical design ensures that the same calibration standards can be used with the M100+ laboratory unit and the MTOL+.

### Bubble rejection system

The optical chamber of the MTOL+ has been designed to eliminate air in the sample while simultaneously creating a vortex cleaning action throughout the optical chamber.

### Calibration

#### (Online & Lab NTU—Use the same Standards)

Calibration with primary standards is completed using sealed cuvettes, similar to laboratory procedures. This method of calibration is fast, clean and reusable. On-screen menu prompts guide you through the calibration procedure quickly and easily. The layouts for the MTOL+ and M100+ have a similar "feel" making the UI transition from one to the other easy.

### Modular design

One-piece mounted design allows for simple mounting and minimal use of space. Wide range of measurement (0-1000 NTU) allows for measurement of both low NTU filtered water or raw water with one analyzer, eliminating the need to learn multiple models. Optical design increases accuracy and provides more consistent readings with online, laboratory and portable turbidimeters. Calibrate the new M100+ laboratory turbidimeter with the same standards as the MTOL+ for greatly improved comparison functionality between lab and online.

### Light source

White light is recommended for use in turbidimeters reporting results under US EPA 180.1 (US standard) jurisdiction. The white light is Tungsten filament, krypton gas filled, and has a life expectancy of 5 to 7 years. Infrared light is recommended for use in turbidimeters reporting results under ISO 7027 (European standard) jurisdiction. Infrared light is also recommended for some waste water final effluent and industrial applications where color is present in the sample stream.

Sensor Base Installation allows up to 1/4" hardware



Power Supply/Junction Box installation allows up to 3/16" hardware

## Technical Specifications

	MTOL+ (Online Turbidimeter)	M100+ (Lab Turbidimeter)
<b>Range Options</b>	0-10 NTU, 0-100 NTU (Default), 0-1000 NTU	0-4000 NTU
<b>Measurement Principle</b>	Nephelometric (90 degree scattered light)	Nephelometric (90 degree scattered light)
<b>Accuracy</b>	2% of reading $\pm$ .02 NTU (below 40 NTU) 5% of reading (above 40 NTU)	2% of reading $\pm$ .02 NTU (below 40 NTU) 5% of reading (above 40 NTU)
<b>Resolution</b>	0.001 (selectable)	0.0001 (selectable)
<b>Response Time</b>	Adjustable (5-500 seconds)	Selectable-Manual or Auto Mode
<b>Flow Rate</b>	0.026-.26 gpm (100 ml/min-1000 ml/min)	NA
<b>Standard Outputs</b>	4-20 mA Galvanic Isolated or RS-485 Modbus	NA
<b>User Alarms</b>	2 User Settable Alarms	NA
<b>Security Code</b>	User Selectable-Prevents Unauthorized Access	NA
<b>Storage Temperature</b>	-4°F to 140°F (-20°C to 60°C)	-4°F to 140°F (-20°C to 60°C)
<b>Data Logging</b>	Yes	Yes
<b>Store Calibration Data</b>	Yes	Yes
<b>Operating Temperature</b>	34°F to 122°F (1°C to 50°C)	34°F to 104°F (1°C to 40°C)
<b>Input Pressure</b>	1-101 psi (built in regulator set at 15 psi)	NA
<b>Enclosure</b>	ABS	ABS
<b>Regulatory Compliance and Certifications</b>	White Light Version compliant to U.S. EPA 180.1 Infrared Version compliant to ISO 7027 and DIN 27027 CE Approved, LC listed to UL 61010-1 3rd Edition: 2012 LC: Certified to CSA 22.2 No.61010-1-12: 2012	White Light Version compliant to U.S. EPA 180.1 Infrared Version compliant to ISO 7027 LC mark tested to UL and CSA. Conforms to CE
<b>Warranty</b>	2 Years from ship date	1 year from ship date

### Online Process Turbidimeter



### Laboratory Turbidimeter

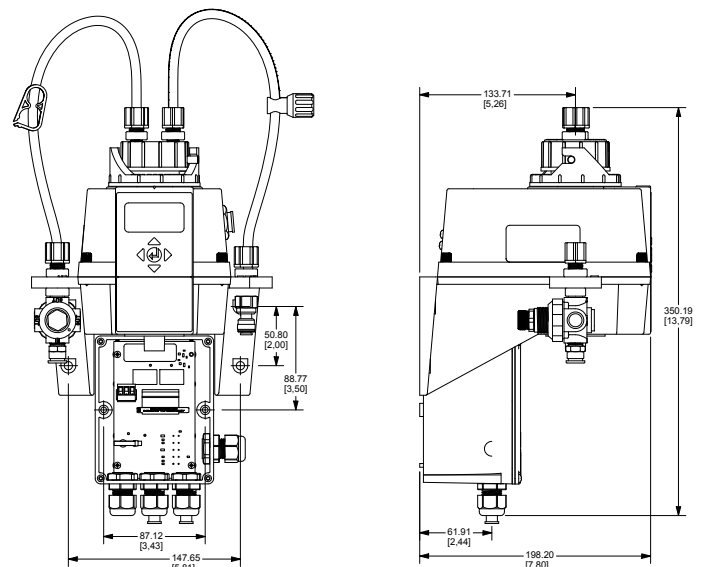

Provide at least 8 inches of free space above the sensor to allow removal for the flow head for maintenance and calibration.

## Ordering Information Turbidimeter System:

When ordering a complete turbidimeter system please order as many online units (MTOL+) as are required and at least one M100+ laboratory turbidimeter (M100+ includes 39940 calibration set).

### MTOL+

#### Ordering Information

Cat. No.	Model	NTU Range	USEPA Method 180.1	ISO 7027
28053	White Light	0-100	X	
28052	Infrared	0-100		X

#### Calibration Kits/Standards

Part #	Description
39953	ProCal Calibration Kit 0.02, 10, 100 NTU
39950	ProCal Calibration Kit 0.02, 1, & 10 NTU
39957	ProCal Calibration Kit 0.02, 10, & 1000 NTU
39825	ProCal Calibration Standard 10 NTU, 125 ml
39824	ProCal Calibration Standard 100 NTU, 125 ml
50040	Formazin Stock Solution Kit

#### Spare Parts

Part #	Description
21555R	Dessicant Refill
20779S	Power Cord 120 VAC / 240 VAC
24166S	Replacement Ultrasonic Cuvette Assembly
24082S	Replacement Lamp Assembly White Light
21369S	Replacement Lamp Assembly IR Light
50036	Replacement Cuvettes, non-ultrasonic (3 Pack)
24306S	Pressure Regulator
21062	Replacement Tubing Kit
02852	Electronic Service Module for MTOL+ IR Light
02853	Electronic Service Module for MTOL+ White Light

### M100+

#### Ordering Information

Cat. No.	Model	NTU Range	USEPA Method 180.1	ISO 7027
28060	White Light	0-4000	X	
28061	Infrared	0-4000		X

#### Calibration Kits/Standards

Part #	Description
39940	ProCal Calibration Kit (0-4000 NTU)
39957	ProCal Calibration Kit (0-1000 NTU)
39825	ProCal Calibration Standard 10 NTU, 125 ml
50040	Formazin Stock Solution Kit

#### Spare Parts

Part #	Description
50051	Cuvettes 28 x 70 mm, 3 pack
50052	Cuvettes 28 x 70 mm, 10 pack
24082S	Replacement Lamp Assembly White Light
21369S	Replacement Lamp Assembly IR Light

Manufacturer's Representative



A WATTS Brand

USA: T: (239) 337-2116 • Toll-Free (888) 203-7248 • F: (239) 332-7643 • HFscientific.com  
Latin America: T: (52) 81-1001-8600 • HFscientific.com