

**DRT-15 C/ER  
PORTABLE TURBIDIMETER**

HF scientific, inc.  
3170 Metro Parkway  
Fort Myers, FL 33916-7597  
Phone: (813) 337-2116  
FAX: (813) 332-7643



## **DRT TURBIDIMETERS**

### **OPERATING INSTRUCTIONS**

#### **FOREWORD**

The DRT Turbidimeters are direct reading Nephelometric instruments which measure scattered light from particles in suspension in a liquid. The optical signal is stabilized and amplified to energize a meter. The instruments use solid state electronic components and resist thermal variation and lamp aging.

All models of the DRT Turbidimeter Instruments provide a linear display of turbidity in Nephelometric Turbidity Units. Note that JTU (Jackson Turbidity Units), FTU (Formazin Turbidity Units) and NTU (Nephelometric Turbidity Units) are comparable.

The material contained in this manual will help the users to take full advantage of the instruments in the majority of applications. However in event that unusual circumstances or problems not covered by this manual arise, please contact your local distributor or the manufacturer.

HF scientific, inc.  
3170 Metro Pkwy  
Fort Myers, Florida 33916-7597  
Phone: (813) 337-2116  
FAX: (813) 332-7643

Our engineering staff is available to help you with your specific needs.



**TABLE OF CONTENTS**

	<b><u>Page</u></b>
I. SPECIFICATIONS . . . . .	1
II. LIST OF STANDARD ACCESSORIES . . . . .	1
III. PRE-OPERATION CHECK OUT . . . . .	2
IV. OPERATION AND DESCRIPTION. . . . .	2
V. RECORDER OUTPUT . . . . .	3
VI. CRITICAL MEASURING AREA . . . . .	3
VII. CALIBRATION PROCEDURES . . . . .	4 - 5
A. Standard Formazin Solutions	
B. Calibration Procedures	
VIII. TROUBLE SHOOTING . . . . .	7
IX. MAINTENANCE . . . . .	8
A. Battery Replacement	
B. Lamp Replacement	
X. PARTS & ACCESSORIES . . . . .	9
XI. WARRANTY . . . . .	10



**I. SPECIFICATIONS FOR DRT-15 C/ER**

Ranges NTU	3 Ranges: 0-20, 0-200 & 0-2000 NTU
Linearity	(+ or -) 5% of Full Scale on 0-20 & 0-200 range (+ or -) 10% of Full Scale on 0-2000 range
Repeatability	(+ or -) 5% of Full Scale on all ranges
Sensitivity	0.01 NTU change on "20" range
Response	Virtually immediate in all ranges
Power Supply	6 Volt battery. 2.6 amp hours 115/230 VAC, 50/60 Battery Charger
Controls	Combination Range Switch for: ON/OFF Range Selection. Reference Adjust
Recorder Output	0-1mA adjustable, 100 maximum resistance
Reference Standard	0.02 NTU (Nominal)
Dimensions	11" x 9 1/4" x 5 1/2" (27 cm) x (22.7 cm) x (13.5 cm)
Weight	4.5 lbs.(2.05 kilograms)
Operating Temperature	0 - 50°C (32 - 122°F)

**II. LIST OF STANDARD ACCESSORIES**

<u>QUANTITY</u>	<u>CAT.#</u>	<u>DESCRIPTION</u>
1	50084	Instruction Manual
1	50047	Reference Standard 0.02 NTU (Nominal)
1	70048	Battery Charger 115 V 60 Hz
<u>OR</u>		
1	70020	Battery Charger 230 V 60 Hz
2	21210	Cuvettes complete with screw top
1	70825	Recorder Plug

### III. PRE-OPERATION CHECK OUT

Extreme care should be taken when handling the Reference Standard or sample cuvettes as surface scratches or finger smudges will cause analysis errors. Handle these items by the top only.

Turn the Range Switch on to either range position in order to observe the condition of the battery. When sufficiently charged the red low battery light will be **OFF**. If the light is **ON**, the battery should be charged a minimum of 12 hours before using the instrument on battery power. When charging the battery, always turn the Range Switch to **OFF**.

**NOTES:** 1. The turbidimeter is not meant to operate from the charger.  
2. If the battery does not have a sufficient charge, the red low battery light will be **OFF**.  
This is because the battery can be discharged to the point where there is insufficient voltage to operate the low battery light. Recharge the battery for proper operation.

The battery, when new, usually requires several cycles of discharging and recharging in order to obtain optimum rated life between charges.

The turbidimeter provides up to 4 1/2 hours of continuous operation as a portable battery operated unit between recharges.

It is recommended that the unit be turned off between readings in order to obtain longer battery life between recharges. If used as a stationary unit leave the charger plugged in, but **TURN OFF INSTRUMENT WHEN NOT IN USE.** This will keep the battery at an optimum level at all times.

### IV. OPERATION AND DESCRIPTION

The EPA recommends that cuvettes used for instrument calibration or sample measurement be matched or indexed.

For accurate measurements in the low range rotate the cuvettes in the well to obtain the minimum reading. Mark the cuvette with one of the adhesive dots provided and the instrument so that orientation of the cuvette will be identical each time it is placed in the instrument.

To operate the turbidimeter, switch to the "20" range and place the Reference Standard (0.02 NTU) in the optical well.

With the light shield in place over the well, adjust the Reference Adjust knob to cause the meter to read the reference standard value on the scale. The unit is now ready for use in either range.

To make a measurement of a sample, clean one of the cuvettes and fill to within approximately 1/2" of top with the sample. Place the top on the cuvette and carefully clean the outside surface of the cuvette with a lint free wiper such as Kimwipes. Place the sample in the well and place the light shield over the well. Select the appropriate range for best readability.

If the instrument has been subjected to cold (below 10 degrees Celsius) and then brought indoors, it should be allowed to warm up before use, since condensation may form on the various lenses. This can be aided by leaving the case open and the instrument on for approximately a half hour.



## V. RECORDER OUTPUT

The DRT-15C/ER is shipped complete with a 0-1 mA Recorder Output. The jack is located on right side of the chassis (refer to J1 on figure 2). To use, connect the 1/8" miniplug provided to your recorder. Adjust R11 to obtain a full scale output compatible to a full scale reading on the DRT-15C/ER. Once this adjustment is made, the DRT-15C/ER will always be set up for this recorder.

## VI. CRITICAL MEASURING AREA

The critical measuring area of the sample containers is the 3/4" wide band starting 5/8" above the bottom. Keep this area clean and free of scratches or abrasion. Handle by the top part only. (See Figure 1).

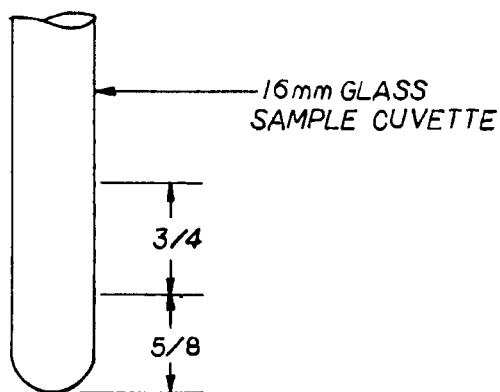

Figure 1

## VII. CALIBRATION PROCEDURES

### A. STANDARD FORMAZIN SOLUTIONS

Calibration of this instrument is based on Formazin, a material which can be made by synthesis and reproduced repeatedly within one percent. When properly mixed, it is uniform in the number, size and shape of its particles, thus making it an ideal turbidity standard. Calibration of this instrument is in Nephelometric Turbidity Units (NTU) based on Formazin.

Calibration samples may be obtained by diluting Formazin stock suspension using "Turbidity-Free" water. Formazin stock suspension may be prepared by the user (Reference A.W.W.A. "Standard Methods", 14th Edition) or it may be purchased in kit form, HF scientific part number 50040.

Each kit contains:

<u>Contents</u>	<u>Units</u>	<u>Qty.</u>
Instruction Manual	ea.	1
Formazin 4000 NTU Stock Solution	500 ml	2
Turbidity-free 0.02 NTU water	gal/4L	1
Selected Cuvettes	ea.	4
Light shield caps	ea.	4
Reference Standard	ea.	1
Pipettes graduated 1ml, 10ml, 25ml	set	1

In addition to the Formazin Kit, Catalog No. 50040, the DRT-15ER and DRT-15C/ER require special glassware. You will need to order four 16mm cuvettes, Catalog No. 21210, and one Reference Standard 0.02 NTU, Catalog No. 50047. Please call HF Customer Service to order.

The following table gives the recommended dilutions of the stock suspension. Be sure to adequately mix the stock suspension prior to removing a portion for dilution.

#### PROCEDURE

NTU value	Pipette	Amount	Base Formazin	Volumetric Flask
2.0 NTU	1.0ml	.5ml	of 4000 NTU	1000ml
19.6 NTU	10.0ml	4.9ml	of 4000 NTU	1000ml
198.0 NTU	10.0ml	9.9ml	of 4000 NTU	200ml
1980 NTU	25.0ml	24.8ml	of 4000 NTU	50ml

**NOTE:** 1. When the prepared samples start to flocculate, they are unreliable and fresh ones must be made. This will occur more rapidly for the lower value diluted suspensions.

**B. ELECTRONIC CALIBRATION USING FRESHLY PREPARED FORMAZIN SOLUTIONS**

The DRT Turbidimeters have been carefully calibrated by the factory. However, should the Electronic P.C. Board, the Photo Detectors, or the Light Source be replaced or if very carefully prepared Formazin suspensions indicate a need for recalibration, this may be easily accomplished in your facility.

To carry out a complete calibration the following Formazin suspension values are required:

- 1980 NTU, - Fill, cap and label a separate  
198 NTU - cuvette with a sample of each.
- 19.8 NTU - Always mix the contents of each  
& 2.0 NTU - cuvette by inverting several times  
before placing in the Optical Well  
for a reading.
- Keep the outside surface of  
cuvettes clean.
- When placing any standards in the  
well, always use the screw cap/shield  
to cover the well in order to keep  
out ambient light.

To gain access to the trimpots, remove the accessories from the foam holder. Refer to figure 2 for trimpot identification during the next few steps.

- 1) Center the reference adjust control on top of the instrument.
- 2) Insert the reference standard and turn the range control on the DRT-15C/ER to the 20 range. Adjust the "Course Zero" trimpot (R2) until a reading of 0.02 NTU is obtained.
- 3) Replace the reference standard with the 19.8 formazin standard and adjust the "20 Range Adjust" trimpot (R7) to obtain a reading of 19.8 NTU  $\pm$  0.1 NTU.
- 4) Replace the 19.8 NTU formazin standard with the reference standard and adjust the reference adjust control to obtain a reading of 0.02 NTU.
- 5) Repeat steps 3 and 4 until no further adjustments are required.
- 6) Turn the range control on the DRT-15C/ER to the 200 range. Insert the 198 NTU formazin standard and adjust the "200 Range Adjust" trimpot to obtain a reading of 198  $\pm$  1 NTU.
- 7) Turn the range control on the DRT-15C/ER to the 2000 range. Insert the 1980 NTU formazin standard and adjust the "2000 Range Adjust" trimpot to obtain a reading of 1980  $\pm$  10 NTU.

This completes the calibration of the DRT-15C/ER.

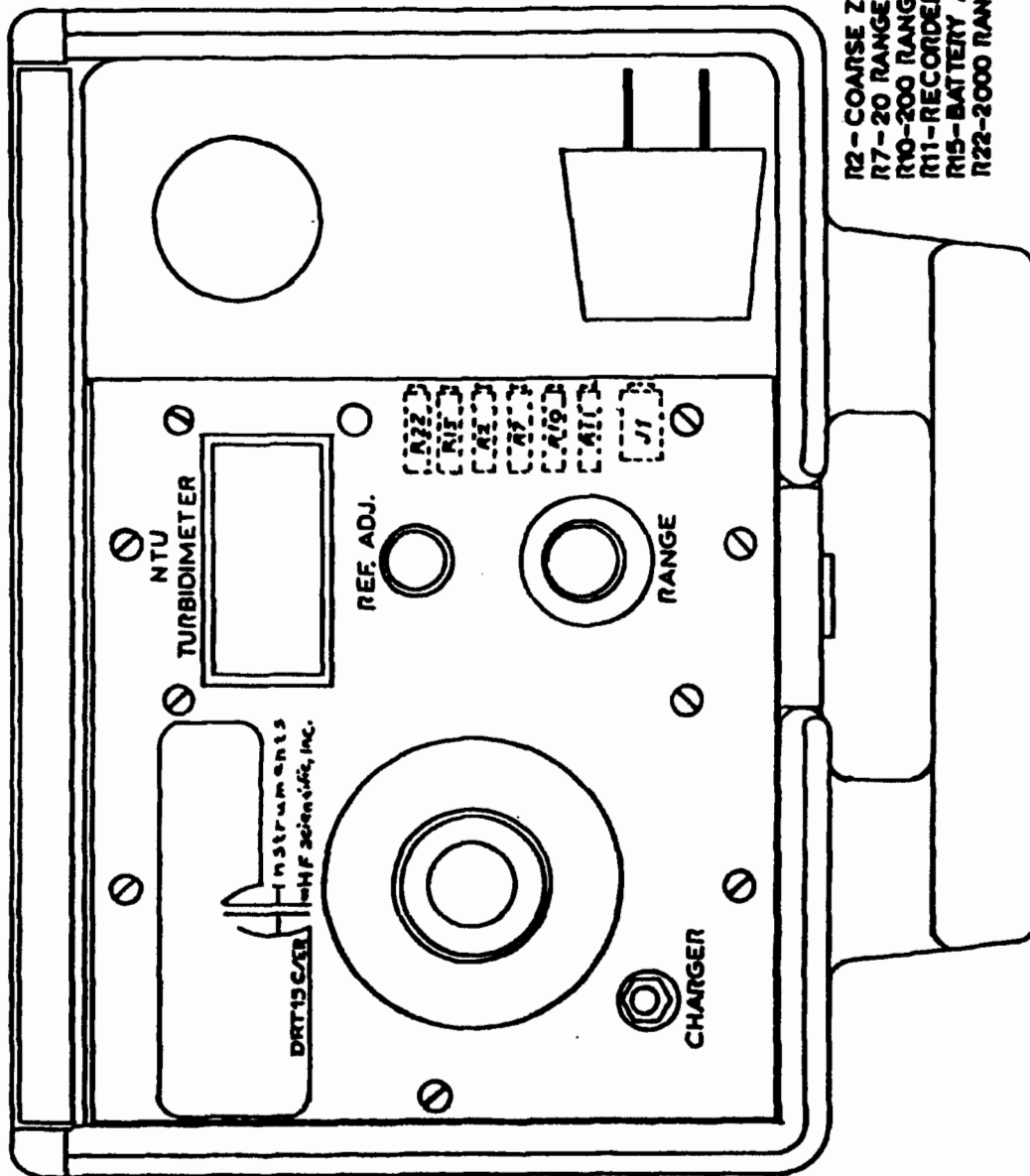

Figure 2

## **VIII. TROUBLE SHOOTING**

### **Symptom**

Meter does not respond when a sample is set into the well.

### **Possible Cause**

1. Lamp is burnt out. Lamp should be replaced.
2. Printed Circuit Board faulty. Replace Printed Circuit Board.
3. Battery is dead. Replace battery.

In the case of 1 or 2 the instrument should be recalibrated. The lamp is an exceedingly long life lamp and therefore replacement is infrequent.

### **Symptom**

Reference Adjust knob does not have enough travel to adjust for the reference standard value.

### **Possible Cause**

1. Scratched or rubbed reference standard container or aged reference standard. Replace the standard.
2. Optics have aged. Recalibrate.
3. Faulty lamp. Replace the lamp and recalibrate.

### **Symptom**

The display will not stabilize when the reference standard is in the well.

### **Possible Cause**

1. Battery has lost its charge. Low battery light is ON when battery requires recharging. When the battery is discharged, the voltage will drop off causing the meter display to drift.
2. Cold sample causes condensation on cuvette which affects the light reading being received by the detectors.
3. Unit has not been given sufficient time to stabilize at ambient temperature conditions after a change of temperature.

## **IX. MAINTENANCE**

The DRT-15/ER is not designed for field servicing. It should be returned to your local distributor or to H.F. scientific for any service requirements. Be sure to obtain return authorization prior to return. This will facilitate prompt servicing of the unit. The exceptions are Battery and Lamp Assembly replacement. This can be done in the field provided the new battery is hooked up in the same manner as the Battery being replaced.

### **A. BATTERY REPLACEMENT**

Should the battery (HF catalog #70006) fail, it can be user replaced. Make certain the instrument is turned off. Remove all the accessories in the foam holder. Next, remove the foam holder by placing a finger in the light shield hole and pulling the rear of the foam forward, then up. The five phillips head chassis screws should be removed. Remove the chassis from the case by sliding the chassis all the way to the right then pulling up. The two screws on the right side of the chassis need to be removed now. This will allow for the removal of the battery clamp and the old battery. Replace the battery by reversing the procedures described above. When connecting the battery, be certain that you connect the red wire to the terminal marked (+) and the black wire to the terminal marked (-).

### **B. LAMP REPLACEMENT**

The lamp source (HF catalog #21084) used in the DRT-15C/ER has an extremely long life. Before replacing the lamp, make certain that the battery is not in need of a charge and is not defective. To replace lamp remove the chassis as described in battery replacement. Remove the lamp wires at TB1 terminals numbers 9 and 10. To remove the lamp, loosen the two set screws on the outermost barrel with a 5/64" hex wrench and pull the lamp straight out. Replace the lamp in the reverse order. Make sure the lamp is pushed all the way in. The set screws should be snugged up; excess pressure could damage the lamp. Replace the chassis in the case and recalibrate as described in calibration procedures.

**X. PARTS & ACCESSORIES**

HF scientific, inc.  
PARTS AND ACCESSORIES FOR  
DRT-15 C/ER

<u>CATALOG NO</u>	<u>DESCRIPTION</u>
50047	Reference Standard 0.02 NTU
50084	Instruction Manual (DRT15C/ER)
50048	Cuvettes - Screw Top, 3/pk.
21084	Lamp Source Assembly 2/pk.
70006	Battery - 6 volt
70048	Battery Charger - 115 volt
20850	Photo Diode
70020	Battery Charger, 230 Volt
20742	LED Display
20491	Printed Circuit Complete
50040	Formazin Stock Solution Kit
70900	Cuvette Cleaning/Conditioning Solution

HF scientific, inc.  
3170 Metro Parkway  
Fort Myers, FL 33916-7597  
Phone: (813) 337-2116  
FAX: (813) 332-7643

This page was intentionally left blank.



## **XI. WARRANTY**

HF scientific, inc., as vendor, warrants to the original purchaser of the instruments to be free of defects in material and workmanship, in normal use and service, for a period of one year from date of delivery to the original purchaser. HF scientific, inc.'s, obligation under this warranty is limited to replacing, at its factory, the instrument or any part thereof. Parts which by their nature are normally required to be replaced periodically, consistent with normal maintenance, specifically lamps, and fuses are excluded. Also excluded are accessories and supply type items.

Original purchaser is responsible for return of the instruments, or parts thereof, to HF scientific, inc.'s factory. This includes all freight charges incurred in shipping to and from HF scientific, inc.'s factory.

HF scientific, inc. is not responsible for damage to the instrument, or parts thereof, resulting from misuse, negligence or accident, or defects resulting from repairs, alterations or installation made by any person or company not authorized by HF scientific, inc.

HF scientific, inc. assumes no liability for consequential damage of any kind, and the original purchaser, by placement of any order for the instrument, or parts thereof, shall be deemed liable for any and all damages incurred by the use or misuse of the instruments, or parts thereof, by the purchaser, its employees, or others, following receipt thereof.

Carefully inspect this product for shipping damage, if damaged immediately notify the shipping company and arrange an on-site inspection. HF scientific, inc. cannot be responsible for damage in shipment and cannot assist with claims without an on-site inspection of the damage.

This warranty is given expressly and in lieu of all other warranties, expressed or implied. Purchaser agrees that there is no warranty on merchantability and that there are no other warranties, expressed or implied. No agent is authorized to assume for HF scientific, inc. any liability except as above set forth.

HF scientific, inc.  
3170 Metro Parkway  
Fort Myers, Florida 33916-7597  
Phone: (813) 337-2116  
FAX: (813) 332-7643