

OWNERS MANUAL

HF – Triple Validation Turbidimeter 0-10, 0-100 NTU

HF scientific, inc.
3170 Metro Parkway
Ft. Myers, FL 33916
239-337-2116

Catalog No. 22634 (5/02)
Rev. 2.6 (.pdf)

DECLARATION OF CONFORMITY

Application of Council Directive

Standard to which Conformity is Declared:

Product Safety - Tested and passed CE EN61010-1:1990 + A1:1992 (73/32 EEC)

Immunity and Emissions – Tested and passed EN61326:1998, Class A

Manufacturer's Name: HF scientific, inc.

Manufacturer's Address: 3170 Metro Parkway, Fort Myers, Florida 33916-7597

Importer's Name:

Importer's Address:

Type of Equipment: Process Turbidimeter

Model No: TVT

Year of Manufacture: 2001, 2002

I, the undersigned, hereby declare that the equipment specified above conforms to the above Directive and Standard

Place: Fort Myers, Florida USA

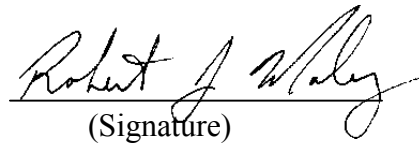
(Signature)

Robert J. Maley, President

Table of Contents

Specifications.....	1
1.0 Overview.....	2
1.1 Unpacking and Inspection of the Instrument and Accessories.....	2
1.2 The Display.....	3
1.3 The Touch Pad.....	3
2.0 Safety.....	4
3.0 Installation and Commissioning.....	5
3.1 Mounting & Site Selection.....	5
3.2 Plumbing.....	6
3.3 Electrical Connections.....	6
4.0 Normal Operation.....	8
4.1 Routine Measurement.....	9
4.2 Security Access Feature.....	9
5.0 Instrument Calibration.....	9
5.1 Calibration Standards.....	10
5.2 Calibration Procedures.....	10
6.0 Calibration by Comparison to Laboratory Measurements (Instrument Offset).....	14
7.0 Instrument Configuration (Range).....	15
7.1 0-100 NTU Range Selection.....	15
8.0 Instrument Configuration (SETUP Mode).....	16
8.1 Displayed Resolution.....	16
8.2 Setting the Year.....	16
8.3 Setting the Day and Month.....	16
8.4 Setting the Time.....	17
8.5 Programming the Alarms.....	18
8.5.1 Alarm 1.....	19
8.5.2 Alarm 2.....	20
8.6 Setting the Analog Output (O/P).....	20
8.7 Configuring the RS485 I/O Port.....	21
8.8 Setting the Security Access Option.....	22
9.0 Troubleshooting/System Alarm Relay.....	23
9.1 System Warning Message(s).....	23
9.2 System Error Message.....	24
9.3 Technical and Customer Assistance.....	24
10.0 Routine Maintenance.....	25
10.1 Cleaning the Optical Chamber (Sample Tube).....	25
10.2 Replacing the Desiccant Cartridge.....	25
11.0 Accessories and Replacement Parts List.....	26
12.0 Warranty.....	27

Specifications

Measurement Range	0.01 –100.0 NTU
Accuracy	±2% of reading plus 0.01 NTU (0-10 NTU) ±5% of reading plus 0.1 NTU (10-100 NTU)
Resolution	0.0001 NTU on low readings
Response Time	Less than 8 seconds
Display	Liquid Crystal Display
Two User Programmable Alarms	120-240VAC 2A Form C Relay with suppressors
Analog Output Signals	4 - 20 mA
Water Pressure	0.1 - 8 bar (1-116 psi.)
Flow Rate	0.5 Liter/min. regulated (.26 Gal/min)
Operating Temperature Range	1°C – 50°C (34°F – 122°F)
Sample Temperature Range	1°C – 50°C (34°F – 122°F)
Supply Voltage to TVT	15 – 18 VDC @ 400 mA
Power Consumption	6 VA
Insulation Rating	Pollution Degree 2, Overvoltage Category II
Regulatory Compliance (0-10 NTU)	White Light Version compliant to U.S. EPA 180.1 Infrared Version compliant to ISO 7027
Approximate Dimensions	175mm W x 310mm H x 225mm D (6.875” W x 12.25” H x 8.875” D)
Shipping Weight	2.5 kg (5.5 lbs.)
Warranty	1 Year from date of shipment

1.0 Overview

The TVT process turbidimeter allows you to measure the turbidity of your process water on-line. The White Light TVT has been designed to meet the design criteria specified by the US EPA on turbidity measurement. The Infra-Red TVT was designed to meet the design criteria specified in ISO 7027 and DIN 27027 for the measurement of the turbidity of a sample.

1.1 Unpacking and Inspection of the Instrument and Accessories

The table below indicates the items that you should find in your turbidimeter shipment.

Item	Part #	Quantity
TVT Turbidimeter	19995 (White Light Version), or 19998 (Infrared Version)	1
Instruction Manual	22634	1
Mounting Kit	22695	1
Power Supply	22578	1
Desiccant Cartridge	19610	1

Remove the instrument from the packing carton. Carefully inspect all items to ensure that no visible damage has occurred during shipment. If the items you received do not match your order, please immediately contact your local distributor or the HF scientific, inc. Customer Service department.

1.2 The Display

Figure 1 illustrates all the items that can appear on the display. The upper row of the display (1) is used for reporting the turbidity levels and to provide user guidance in the customer setting routine. The lower row of the display (2) is used to communicate error messages and user guidance. The display has several status indicators (3) that distinguish the operation of the instrument. In addition there are several indicators that display the different scales (4) that the instrument will report. Other indicators (5) provide guidance when the setup and calibration routines are being used.

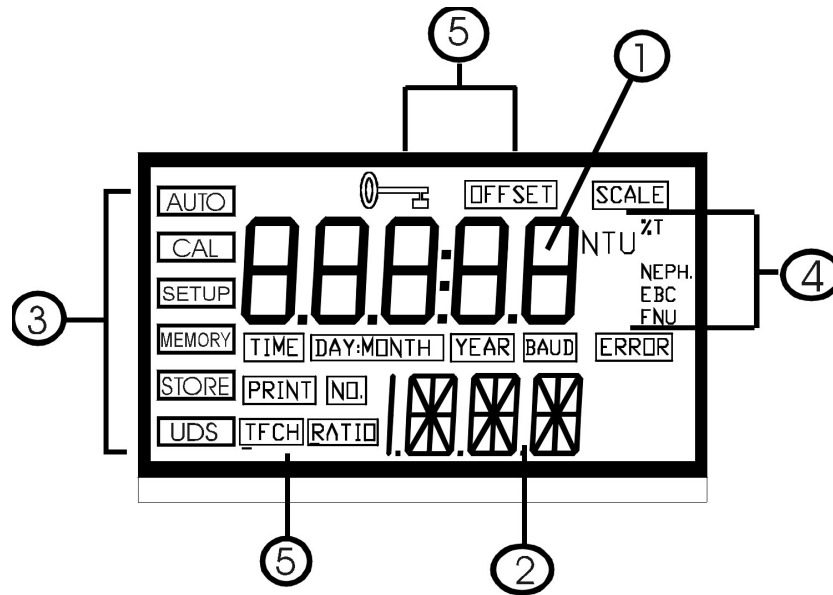

Figure 1- Display used in the instrument.
All items used on the display are shown in this figure

1.3 The Touch Pad

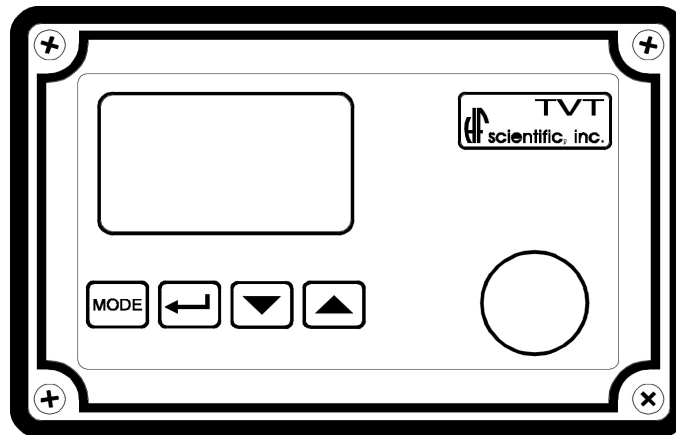

Figure 2: The Instrument touch pad.

Figure 2 illustrates the touch pad. The touch pad has four buttons: **MODE**, **↵**, **▲**, and **▼**. The **MODE** button is used to cycle between the three operational modes of the instrument: **CAL**, **SETUP**, and **AUTO** (Measurement) mode. The **↵** button enters the option (or mode) that is highlighted or chosen. The **▲** and **▼** buttons are used to scroll through lists and to increase or decrease settings.

2.0 Safety

This manual contains basic instructions that you must follow during the commissioning, operation, care and maintenance of the instrument. The safety protection provided by this equipment may be impaired if it is commissioned and/or used in a manner not described in this manual. Consequently, all responsible personnel must read this manual prior to working with this instrument.

All relay contacts are held at the last valid condition and will not change state while the instrument is in the calibration and/or in the configuration mode. In addition, in these modes, the instrument has a time-out feature that automatically returns the system operation to the normal operation mode from any other mode after a five (5) minute period of inactivity.

In certain instances **NOTES**, or helpful hints, have been highlighted to give further clarification to the instructions. Refer to the *Table of Contents* to easily find specific topics and to learn about unfamiliar terms.

3.0 Installation and Commissioning

3.1 Mounting & Site Selection

The instrument is designed for wall mounting. If wall mounting is not practical, the instrument can be mounted on any suitable level surface. For ease of service there should be about 45cm (18") free area above the instrument; this will ensure enough room for calibration and cleaning the optical well. Choose a location that is easily accessible for operation and service and ensure that the front display rests at eye level. The overall mounting dimensions of the instrument are shown in Figure 3. The recommended mounting screws (four are required) are M6 (or 1/4").

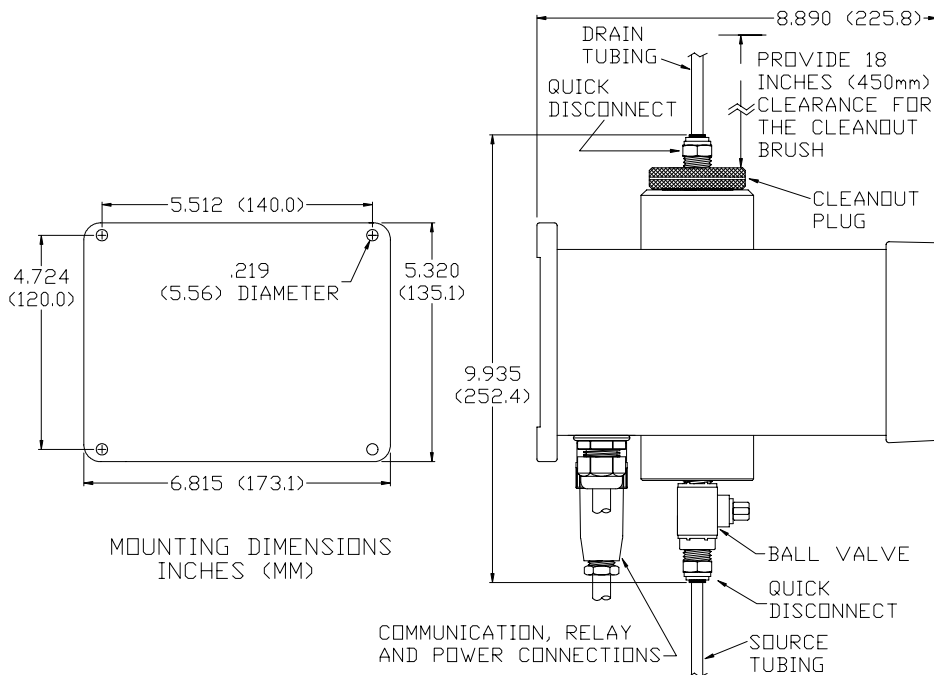

Figure 3: Overall mounting dimensions of the instrument

It is critical that the instrument be mounted as close as possible to the sampling point to ensure an accurate reading of turbidity (within 6-10 ft of the sampling point).

Note: If the instrument is to be mounted onto a metal surface that is grounded, or if any of the mounting hardware contacts a grounded object, the plastic mounting bars included in the shipping package should be used to ensure isolation of the 4-20 mA signal. Figure 4 provides a depiction of the use of the mounting hardware. Attach the two mounting bars to the back of the instrument as shown in Figure 4 first. Then, mount the instrument to the wall. The mounting bars will accept screws up to 1/4" diameter.

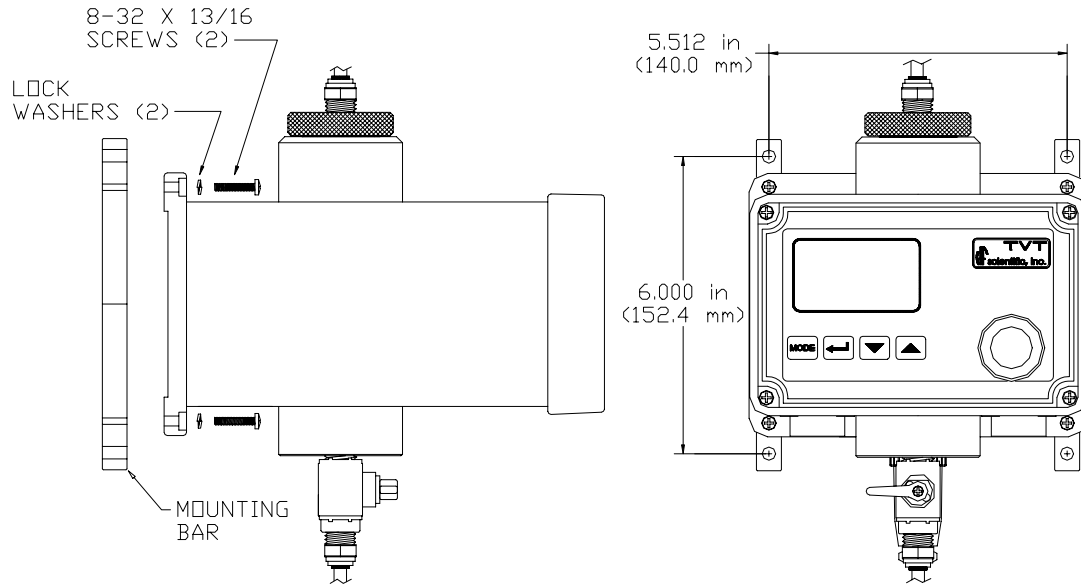

Figure 4: Use of the optional mounting bars to ensure isolation of the 4-20 mA output

3.2 Plumbing

The recommended plumbing for the instrument is shown in Figure 3. The instrument is designed to limit the flow to the range of 0.4 – 0.6 liters/minute depending on the system backpressure. Ensure that you supply the instrument with a process flow capable of sustaining this level. Quick-connect fittings are supplied on the inlet and outlet of the instrument; these fitting help speed up calibration procedures. These fittings will accept 0.25" OD x 0.170" ID tubing. Opaque tubing should be used if the tubing will be exposed to sunlight

3.3 Electrical Connections

All of the electrical connections to the TVT except power, are made through cables located on the lower section of the instrument. While facing the instrument, the right connector is used for power supply (15 –18 VDC) connections. The middle cable is used for the relay contact connections. The left cable provides the communication signals. As you read the following sections, please refer to Figure 4 for clarification of the electrical connections.

Please follow all local and government recommendations and methods for installation of electrical connections to and between the instrument and other peripheral devices.

Note: Only qualified electricians should be allowed to perform the installation of the instrument as it involves a line voltage that could endanger life.

Power: The input power connector is pre-assembled with either universal or a wall mount power supply. Alternatively, if you can supply clean 15 –18 VDC to the system you can do so without using a power adapter. In this instance the cable used for power has 4 pins for connections. The connections are shown below:

Pin 1	=	15 –18 VDC (Not Polarity Sensitive)
Pin 2	=	15 –18 VDC (Not Polarity Sensitive)
Pin 3	=	No Connection
Pin 4	=	No Connection

Please observe safe wiring practices. It is recommended that a circuit breaker or switch be placed prior to the power connection to the TVT to allow for service.

Relays: The instrument is pre-wired with a 1.8m (6 ft.) long 9-wire relay cable. Please Note that the alarms are fail-safe in the manner that the relays are normally actuated and a loss of power will change the relays' state. The color code is shown below:

Orange	=	Alarm 1 Normally Closed (open on alarm or on loss of power)
Yellow	=	Alarm 1 Common
Blue	=	Alarm 1 Normally Open (closed on alarm or loss of power)
Green	=	Alarm 2 Normally Closed (open on alarm or on loss of power)
Violet	=	Alarm 2 Common
Grey	=	Alarm 2 Normally Open (closed on alarm or loss of power)
Black	=	Sensor Alarm Normally Closed (open on alarm or on loss of power)
Brown	=	Sensor Alarm Common
Red	=	Sensor Alarm Normally Open (closed on alarm or loss of power)

The Alarm 1 and Alarm 2 relays are mechanical relays rated at 240 VAC 2A. There is also a Sensor Alarm relay that is a mechanical relay rated at 24 VDC 1A. Please note that the relays are labeled NO (Normally Open), NC (Normally Closed) and C (Common). As these alarms are configured fail-safe, the normal condition is with power applied and in a non-alarm condition. Operation of these alarms is covered in section 8.5 *Configuring the Alarms*

Communication Signals: Depending on the option that was purchased with the instrument, several outputs come pre-wired to the instrument with a 1.8m (6 ft.) long cable. The connections are shown below:

Brown	=	RS 485 A
Red	=	RS 485 B
Orange	=	RS 485 Shield
Yellow	=	Flow Switch (Optional Accessory)
Green	=	Flow Switch (Optional Accessory)
Blue	=	4-20 mA Positive Connection
Black	=	4-20 mA Negative Connection

RS 485: The RS485 half-duplex (2-wire) digital interface option operates with differential levels that are not susceptible to electrical interferences. This is why cable lengths up to 3000 ft can be implemented. The last device on every bus must be terminated with a 120 ohm resistor to eliminate the possibilities of signal reflection on the line. Do not run RS 485 cables in the same conduit as power.

Ensure each instrument is not powered when connecting the RS 485 line. Connecting an instrument while powered may cause the instrument to unnecessarily reset and proceed through the power on checks.

4-20 mA: The 4-20 mA output is driven by a 12 VDC power source and can drive recorder loads up to 450 ohms. This 4-20 mA output is isolated from line power and earth ground. Do not run 4-20 mA cables in the same conduit as power. Operation of these alarms is covered in section 8.6 *Setting the analog Output (O/P)*.

Ensure each instrument is not powered when connecting the 4-20 mA line. Connecting an instrument while powered may cause the instrument to unnecessarily reset and proceed through the power on checks.

4.0 Normal Operation

This process turbidimeter allows you to measure the turbidity of your process water on-line. The turbidity of the process water is reported in Nephelometric Turbidity Units (NTU). Readings above 10 NTU (100 NTU if range of 0-100 NTU is enabled) are outside the range of this instrument.

During normal operation, the instrument will have the **AUTO** block highlighted with the current scale displayed on the lower row of the display and the measured reading on the upper row of the display (see illustration below).



In certain instances, during normal operation, the instrument will display a row of dashes across the upper row of the display

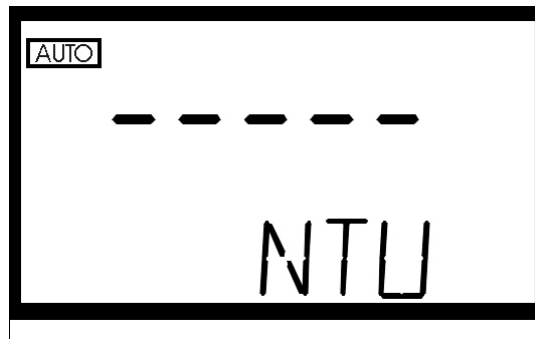

This indicates that either the instrument is performing an auto-ranging function, or the sample has a substantial amount of bubbles. If the dashes remain for an extended period of time please ensure that the sample does not have a large amount of bubbles present; if there are not bubbles present, please contact the HF scientific, inc. Technical Services Department for further assistance and guidance.

4.1 Routine Measurement

The following steps describe how to measure the turbidity of a sample using this instrument:

1. Apply power to the instrument and allow the unit to warm up (typically 45 minutes – 1 hour on initial commissioning).
2. When a continuous process stream is flowing through the instrument, the instrument will display the measured turbidity level of the sample by displaying it on the LCD screen. In addition, the equivalent signal is provided on the analog output and the timed digital output (if selected).

4.2 Security Access Feature

The instrument is equipped with a security access code feature that can be activated in the configuration mode. If the security feature is enabled, the screen shown in the illustration below will appear when you press the **MODE** button.

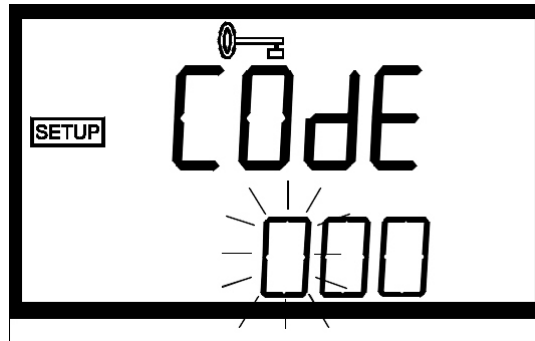

The security code has three numbers that are selectable one at a time. Notice that the first number in the code is flashing; the flashing indicates that this is the number to be changed. Use the \blacktriangle or \blacktriangledown arrows to select the value of the first number in the code and then press the \blacktriangledown button to accept the first number of the code. After you have pressed enter, the second number in the code will start to flash. Proceed as with the first number. Then repeat the process for the third number in the access code.

If you have selected a valid access code, the instrument will be directed to either the calibration or the user setup mode depending on the access code that was provided to the instrument. If the wrong access code is selected, the instrument will return to the **AUTO** mode.

Note: Only three access codes are used in the instrument: one for instrument calibration (333), one for calibration by comparison/offset (555) and one for instrument configuration (444); these codes are not programmable.

5.0 Instrument Calibration

The instrument was calibrated and tested prior to leaving the factory. Therefore, it is possible to use the instrument directly out of the box. However, re-calibration of the instrument is recommended to help you become familiar with the operation of the

instrument and the calibration procedures. Under normal conditions, re-calibration is recommended at least once every three months¹.

During calibration, the instrument performs several system self-diagnostics. As such, several warning messages may be displayed. If the instrument detects an irregularity with the instrument (detectors or lamp) a warning message will be displayed on the lower row of the display on exit from the calibration mode. If this occurs please attempt to rectify the warning message yourself, or contact the HF scientific, inc technical services department. In any event, the instrument will continue to monitor the turbidity of the process water with a decreased accuracy until the error is rectified.

In addition, if the instrument remains in the calibration mode for longer than 5 minutes with no activity, it will time out and return to the automatic measuring mode.

5.1 Calibration Standards

We recommend that you use the following materials during calibration to achieve the accuracy stated in this manual:

1. De-ionized water filtered through a 0.02 µm filter
2. 10.0 NTU Formazin primary standard, or 10.0 NTU pour through Calibration Standard available from HF scientific, inc.
3. 100 NTU Formazin primary standard, or 100 NTU pour through Calibration Standard available from HF scientific, inc.

It is well known that diluted Formazin is unstable. If you choose to use Formazin to calibrate the instrument, ensure that you are using a fresh stock suspension of Formazin to achieve the accuracy quoted for the instrument. A Formazin Stock Solution Kit is available from HF scientific, inc. (Catalog No. 50040). The HF scientific, inc. calibration standards (Catalog No. 19996) are more stable than Formazin and have a shelf life of 1 year. Prior to re-calibration, review the expiration date to ensure that the standards have not expired.

5.2 Calibration Procedures

All TVT's are shipped with a range of 0-10. A range of 0-100 NTU may be selected by adding the included shorting strap (See section 7). If you did not request a measurement range then you have a 0-10 NTU instrument. If you selected a range of 0-100 in section 7, then you should complete steps 7-10 using a 100 NTU standard first and then repeat the steps with a 10 NTU standard.

1. Select the calibration function of the instrument by pressing the **MODE** button once. The “**CAL**” block will be illuminated on the display with the turbidity value of 10.0 (or 100 for 0-100 NTU range) NTU displayed on the LCD. This is the first standard that should be used in calibration.

¹ The EPA recommends that on-line turbidimeters be calibrated with the primary standard (Formazin) at least once every three months if they are to be used for EPA reporting.

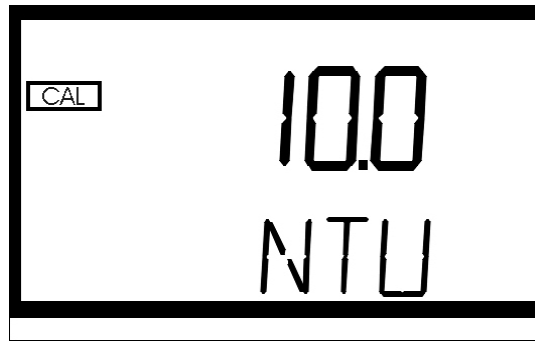

2. Shut off flow to the instrument.
3. Disconnect the quick connects at the top and bottom to separate the instrument from the process stream, then unscrew and remove the cleanout plug on the instrument.
4. Open the drain valve to allow the process water to drain from the sample well and then close the drain. Capture this water in a container if spilt water is not wanted.
5. Pour 0.02 NTU or “turbidity free” water into the optical well and use the brush, provided with the instrument, to clean out the sample well.
6. Drain the sample well and rinse the well at least twice with 0.02 NTU water.
7. After the sample well is drained close the drain valve and add 10.0 NTU calibration standard to rinse out the optical well. Repeat this step and drain the optical well.
8. Pour the 10.0 NTU calibration standard into the sample well (ensure that the well is completely filled). Place the black cleanout plug back on the sample well (to block light).

Note: If you choose to use Formazin, be sure to clean the sample well immediately after using Formazin and prior to returning to the measurement mode.

9. Press the ↵ button to indicate to the instrument that you wish to calibrate on the 10.0 NTU calibration level. Once you have pressed the ↵ button, the current reading will be actively displayed on the LCD display.

Wait for the reading to stabilize, once the reading has stabilized press the ↵ button again. The word *CAL* will appear on the *upper row* of the LCD display and the word *NO* will appear on the *lower row* of the LCD display.



10. This is the final step for calibration at the 10.0 NTU level; if you wish to exit without calibrating simply press the ↵ button. However, if you are satisfied and wish to complete calibration on the 10.0 NTU level use the ▲ ▼ arrows to select the word *YES* on the lower

row of the display and then press the ↵ button to initiate calibration.

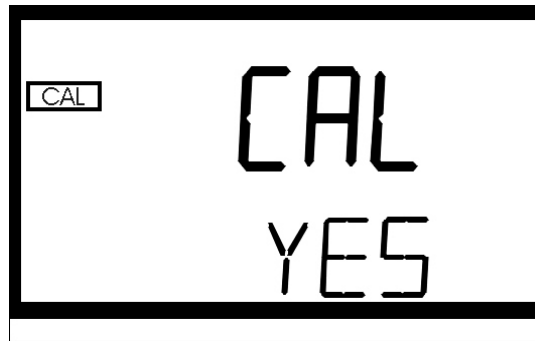

Both the **CAL** and **STORE** blocks will flash during the operation and the word *YES* will change to a count down starting at 90.

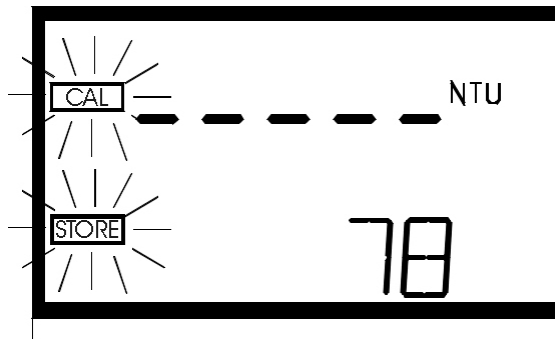

When the calibration procedure for the 10.0 NTU level is complete the **CAL** and **STORE** blocks will stop flashing. You will see the following on the display:

11. Then, you will see the following on the display:

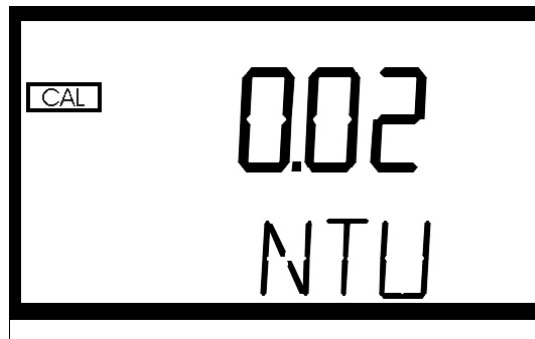

12. Drain the 10.0 NTU calibration standard from the sample well and rinse the well at least twice with 0.02 NTU water.
13. Fill the well with 0.02 NTU water and then place the black cleanout plug on the sample well (to block light).
14. Press the ↵ button to indicate to the instrument that you wish to calibrate on the 0.02 NTU calibration level. Once you have pressed the ↵ button, the current reading will be actively displayed on the LCD display. Wait for the reading to stabilize, once the reading has stabilized press the ↵ button again. The word *CAL* will appear on the *upper row* of the LCD display and the word *NO* will appear on the *lower row* of the LCD display.
15. This is the final step for calibration on the 0.02 NTU level; if you wish to exit without

calibrating simply press the ↵ button at this time. However, if you are satisfied and wish to complete calibration on the 0.02 NTU level use the ▲ ▼ arrows to select the word *YES* on the lower row of the display and then press the ↵ button to initiate calibration. Both the **CAL** and **STORE** blocks will flash during the operation and the word *YES* will change to a count down starting at 90. When the calibration procedure for the 0.02 NTU level is complete the **CAL** and **STORE** blocks will stop flashing.

Note: Prior to exiting the calibration routine ensure that the process water is flowing through the sample chamber. This will help prevent unwanted spikes in the outputs from the instrument.

16. The word *END* will appear on the lower row of the LCD display.



Pressing either the **MODE** button or the ↵ button will complete calibration. If you press the **MODE** button two times you will return to the **AUTO** mode.

- Note: 1. At any point in time during calibration you can cycle through the required calibration points (0.02 NTU, 10 NTU, and 100 NTU) by pressing either the ▲ or ▼ buttons. This allows you to individually calibrate with a particular calibration standard.**
- 2. If you wish to exit the calibration mode you may do so at any time, prior to initiating a calibration, by simply pressing the ▲ or ▼ buttons until the word “END” appears on the lower row of the display. Once you reach this point, simply press the enter button.**

6.0 Calibration by Comparison to Laboratory Measurements (Instrument Offset)

In certain instances, you may wish to use an offset factor to calibrate your instrument rather than performing a physical calibration of the instrument (as described in section 6.2). This procedure is not recommended in lieu of regular instrument calibration but it can be used in situations where the number of instrument's used makes regular calibration prohibitive. This calibration technique will make the instrument accurate *only* at turbidity levels in the immediate vicinity of the grab sample and *not* in the full range of the instrument.

The procedures are as follows:

1. Collect a grab sample of the process water that is being monitored by the instrument and

- record the turbidity reported by the instrument.
2. Take the grab sample and measure its turbidity using your laboratory turbidimeter (contact the HF scientific, inc. customer services department for examples of laboratory turbidimeters).
 3. Compare the turbidity reported by the instrument to that obtained in your laboratory. If the readings are very close, then no offset adjustment or calibration is required and you may stop the procedure at this step. However, if the readings are substantially different, you may continue on in this procedure to utilize the offset option to improve the turbidity reading of the instrument so that it will agree with your laboratory reading between calibrations.
 4. Select the calibration-offset function of the instrument by pressing the **MODE** button until the “**OFFSET**” and “**CAL**” blocks are illuminated on the display.



5. At this point, the lower row of the display will indicate the operational status of the offset function (on or off). You may change this status by using the \blacktriangle and \blacktriangledown buttons. Once you have set the desired operational status of the offset function press the \blacktriangledown button to accept it. If you turned the option off, you will return to the **SETUP** mode. Press **MODE** to return to the automatic measurement mode.
6. If you turned the option on, you will be prompted to enter the laboratory measurement of the grab sample (LAB).

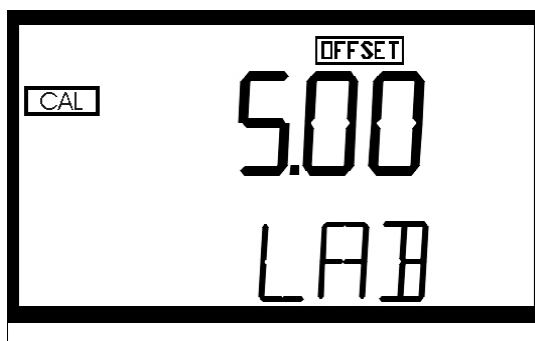

- Select the turbidity level for your grab sample using the \blacktriangle and \blacktriangledown buttons. Once you have set the desired level, press the \blacktriangledown button to accept it.
7. Next, you will be prompted to enter the on-line measurement of the grab sample (OLR).

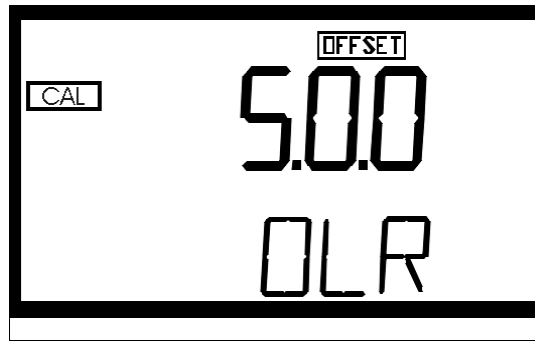

Select the turbidity level that the instrument reported for your grab sample using the ▲ and ▼ buttons. Once you have set the desired level, press the ↵ button to accept it.

8. This completes the offset configuration.
9. At this point, the instrument will continue to the configuration (setup) mode of the instrument.

7.0 Instrument Configuration (Range)

In order to reduce maintenance during calibration, all TVT's are shipped from the factory with a range of 0-10 NTU. The instrument is capable of, and has been factory calibrated for a range of 0-100 NTU. It is recommended that this higher range not be used unless needed.

7.1 0-100 NTU Range Selection

To select this range, loosen the four front panel screws and pull the front chassis forward about 10 cm (4 inches). On the inside of the front panel there is a shorting strap taped to the surface. Remove the strap, and pull off and discard all the tape. Locate the selection jumpers on the printed circuit board, just above the desiccant cartridge. Place the shorting strap on the very front two pins, numbered 4. The instrument must be reset to recognize the change in configuration. If the instrument is under power, press the small push button labeled S1 on the left front of the printed circuit board. If the instrument is not under power, the TVT will recognize the change when power is applied. Close up the instrument by sliding the chassis back into the cover and tightening the four front panel screws.

When calibrating with the 0-100 range, be sure to read in entirety the calibration instructions (see section 5.2).

8.0 Instrument Configuration (SETUP Mode)

The instrument has been designed to provide you with the ability to customize your instrument according to your needs at any time during normal operation. This mode has been split into sub-menus to facilitate instrument configuration. This section describes how you can use each of the sub-menus to configure your instrument

Enter the **SETUP** mode of the instrument by pressing the **MODE** button until **SETUP** is illuminated, then press the ↵ button.

Note: To skip the selection of the SETUP mode, simply press the MODE button.

8.1 Displayed Resolution

The instrument is equipped with the ability to display several levels of resolution. The instrument can display up to four digits to the right of the decimal place for turbidity readings below 10 NTU. If you feel that the last digit, or two, is not stable then you may adjust the resolution to not show these digits. Upon entering the **SETUP** mode the lower row of the display will show “RES” and the upper row of the display will show the number of digits that will be displayed.

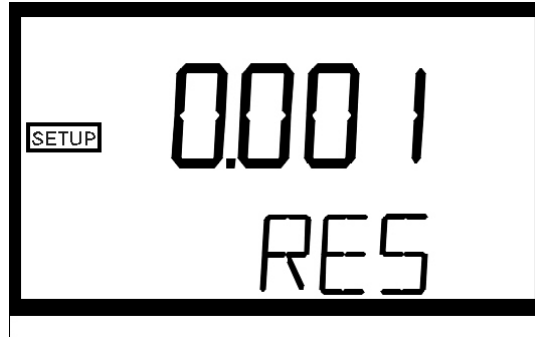

Change the resolution by pressing the \blacktriangle or \blacktriangledown button. When you have selected the desired digit resolution press the \blacktriangledown button. After pressing the \blacktriangledown button, the **YEAR** block will be highlighted and the current year will be displayed

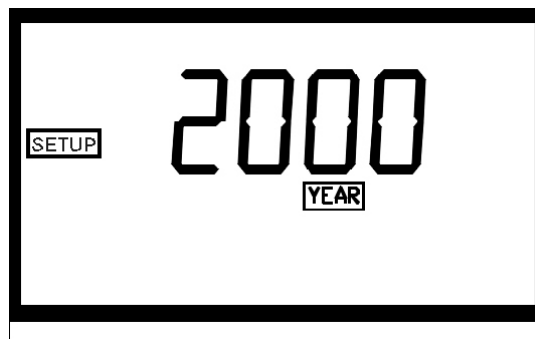

8.2 Setting the Year

With the **YEAR** block highlighted and the year displayed, change the displayed year using the \blacktriangle or \blacktriangledown buttons. When you have selected the proper year press the enter button (\blacktriangledown) to accept the year.

8.3 Setting the Day and Month

After pressing the \blacktriangledown button, the **DAY:MONTH** block will be displayed and you will see two numbers on the *upper* LCD screen. The number flashing corresponds to the month.

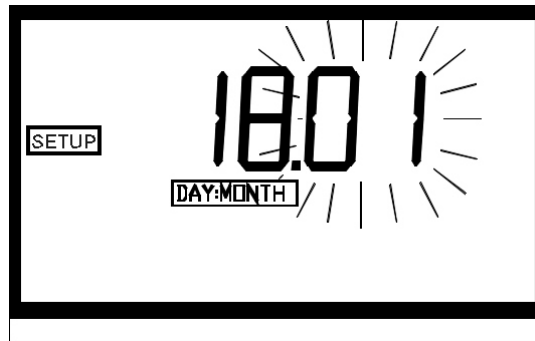

Select the correct month by pressing the \blacktriangle or \blacktriangledown button to change the displayed month. When you have selected the proper month, press the \blacktriangledown button. After pressing the \blacktriangledown button, the second number on the *upper* LCD screen will start to flash: this number corresponds to the day of the month.

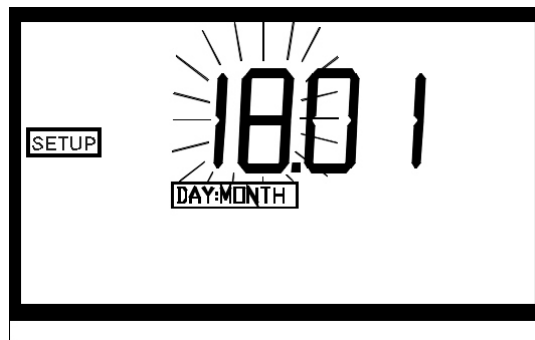

Select the correct day by pressing the \blacktriangle or \blacktriangledown buttons to change the displayed day. When you have selected the proper day, press the \blacktriangledown button.

8.4 Setting the Time

After pressing the \blacktriangledown button, the **TIME** block will be displayed and you will see the time displayed on the *upper* LCD screen in 24-hour format. The number flashing corresponds to the hour.

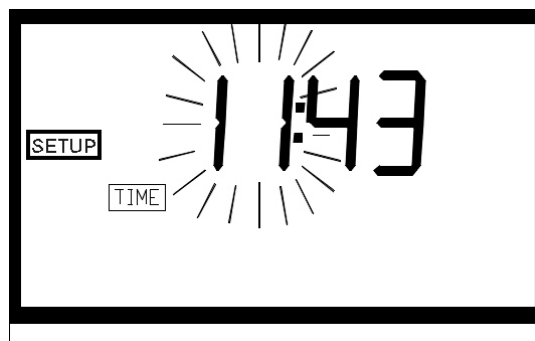

Select the correct hour by pressing the \blacktriangle or \blacktriangledown button to change the displayed hour. When you have selected the proper hour, press the \blacktriangledown button. After pressing the \blacktriangledown button, the second number on the *upper* LCD screen will start to flash: this number corresponds to minutes.

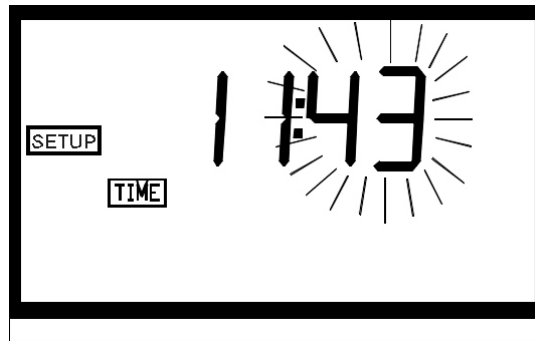

Select the correct minutes level by pressing the \blacktriangle or \blacktriangledown button to change the displayed minutes. When you have selected the proper minute's level, press the \blacklrcorner button.

8.5 Programming the Alarms

The instrument is equipped with two relays that are designed to operate as two independent programmable alarms. You must input three types of information to fully program each alarm:

1. The alarm function (HI, LOW, or OFF)
2. The alarm set point (level at which the alarm activates)
3. The delay time for the alarm: the time that the set point must be exceeded prior to alarm activation (prevents ringing in the relay)

These three items are described below.

Alarm Function: The alarms can either be turned OFF or programmed in one of two different manners:

1. HI alarm: the relay changes state when the measured turbidity level is higher than the programmed alarm level for a prescribed amount of time.
2. LOW alarm: the relay changes state when the measured turbidity level is lower than the programmed alarm level for a prescribed amount of time.

Note: The relays automatically change state when an internal system failure is detected

Alarm Set Point: The level at which an alarm activates is called the alarm set point. On the instrument, the alarm set point is designated as "S/P". The set point is adjustable to any valid turbidity level over the range of the instrument in steps of 0.01 NTU.

Alarm Delay Time: The alarm delay times are used to prevent ringing of the alarm when the measured turbidity level is close to the set point. The function of the delay times is as follows:

Delay On: The turbidity level must exceed the alarm set point continuously for at least this number of seconds before the alarm activates.

If the delay on time is set at 5 seconds and the process turbidity exceeds the set point continuously for only 4 seconds, the alarm will not be activated. However, process turbidity exceeds the set point continuously for 5 seconds or more, the instrument will activate the alarm.

Delay Off: The turbidity level must not exceed the alarm set point continuously for at least this number of seconds prior to deactivation of the alarm.

If the delay off time is set to 5 seconds and the process has exited out of the alarm condition, the alarm will be reset only if the process is out of the alarm condition for a continuous 5 seconds. Otherwise, the instrument will still signal an alarm condition.

8.5.1 Alarm 1

Alarm 1 Function: The “Alarm 1” is highlighted and the lower row of the display indicates the current function of alarm 1 (HI, LOW, or OFF). You can use the ▲ or ▼ buttons to cycle through and select the desired function. Press the ↵ button to accept your selection.

If you selected to turn the alarm OFF, you will be immediately prompted to set up alarm 2 (go to section 8.5.2). If, on the other hand, you selected one of the other functionalities you will be prompted to set the delay times.

Alarm 1 Delay Times: *Delay On:* The following display will appear to allow you to select the number of seconds currently set for the “delay on” time.

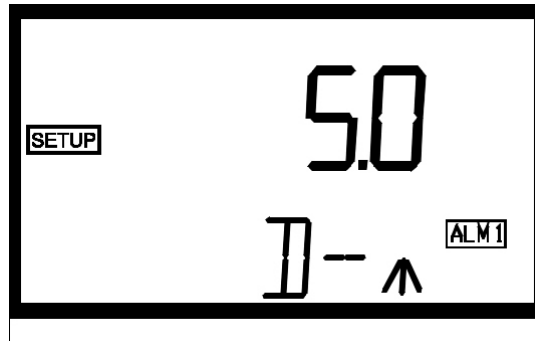

The current selected number of seconds will be shown. You can select the desired number of seconds for the “delay on” time for this alarm using the ▲ and ▼ buttons. Once you have set the desired delay time, press the ↵ button to accept it.

Delay Off: Next, the following display will appear to allow you to select the number of seconds currently set for the “delay off” time.

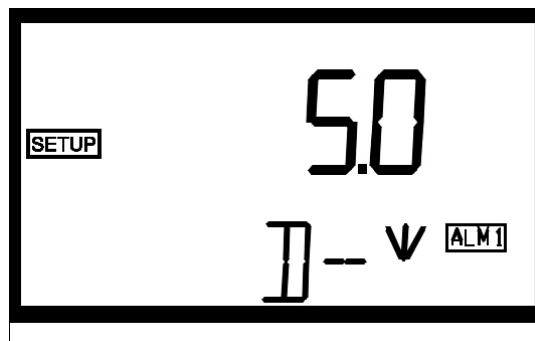

The current selected number of seconds will be shown. You can select the desired delay on time for this alarm using the ▲ and ▼ buttons. Once you have set the desired delay time, press the ↵ button to accept it.

Alarm 1 Set Point: Finally, you will be prompted to select the set point for this alarm; this is indicated by “S/P” shown on the lower row of the display. You can select the desired alarm level by using the ▲ and ▼ buttons. Once you have set the desired set point, press the ↵ button to accept it. After you complete the settings for alarm 1 you will be prompted to set up information on alarm #2.

8.5.2 Alarm 2

Repeat the procedure listed in section 8.5.1 to set up the parameters for alarm 2. If you select to turn the alarm OFF, you will be immediately prompted to set up alarm set up the analog output (go to section 8.6). If, on the other hand, you selected one of the other functionalities you will be prompted to set the delay times and the set point as with Alarm #1.

Once you complete the selections for Alarm #2 you will be prompted to set up the analog output.

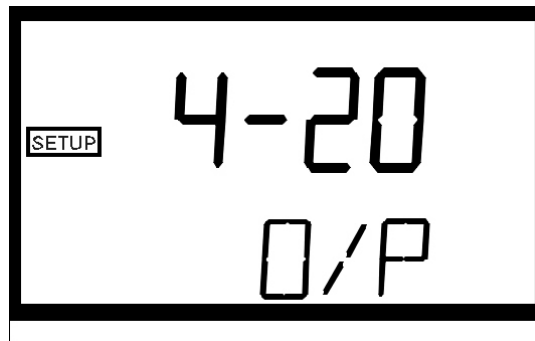

8.6 Setting the Analog Output (O/P)

The output (O/P) selection allows you to turn the 4 – 20 mA analog output on, or off. You can select the desired analog output operation using the ▲ and ▼ buttons. Once you have set the desired operation, press the ↵ button to accept it.

If you selected to turn the 4-20 mA output on, you will be prompted to set the upper (OHV) and lower (OLV) turbidity levels corresponding to the 4 mA and 20 mA output levels. First, you will be prompted with the turbidity level assigned to the 4 mA output level:

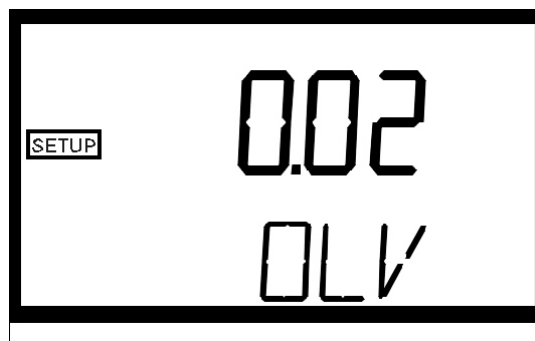

Select the turbidity level you wish to assign to the OLV using the ▲ and ▼ buttons. Once you have set the desired level, press the ↵ button to accept it.

Next, you will be prompted with the turbidity level assigned to the 20 mA output level (OHV on the *lower row* of the LCD display).

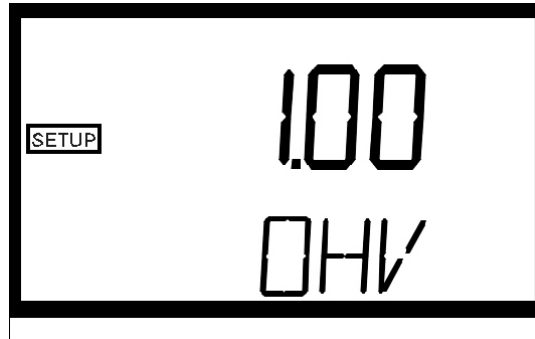

Select the turbidity level you wish to assign to the OHV using the \blacktriangle and \blacktriangledown buttons. Once you have set the desired level, press the \blacktriangledown button to accept it. At this point you will be prompted to set up the digital output (PRINT) option.

8.7 Configuring the RS485 I/O Port

Automatic/Timed Printouts: After pressing the \blacktriangledown button, the **PRINT** block will be highlighted. The lower row of the display will indicate whether this option is turned off or to one of the printing intervals.

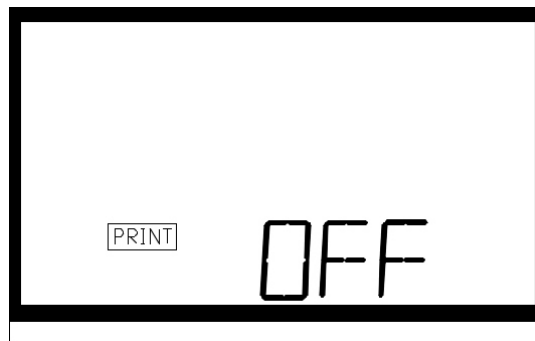

You may select the status of this option (OFF, interval print: 15 min, 30 min, 1 hour, 4 hour, 8 hour, or 24 hour) by pressing the \blacktriangle or \blacktriangledown button.

Note: The timing for the interval starts at midnight.

When you have selected the proper printing option press the \blacktriangledown button. If you selected to turn off the printing function, pressing the \blacktriangledown button will allow you to continue on to configuring the Security Access Code.

If, on the other hand, you selected a printing interval the instrument will print out the average turbidity level, time, and date for the interval that you select at your specified Baud Rate. This is the next item to be configured:

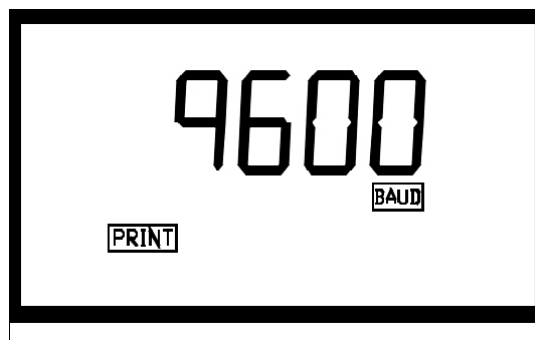

Select the correct baud rate (1200, 2400, 4800, or 9600) for operation of the I/O port by pressing either the \blacktriangle or \blacktriangledown button to change the displayed baud rate. When you have selected the proper baud rate press the \blacktriangledown button to continue on to configure the security access option. The other parameters for the digital communication are no parity and one (1) stop bit.

Note: The information printed out in the timed printout has the format: x.xx NTU dd Mmm yyyy hh:mm. The resolution of the turbidity level output is the same as the resolution of the turbidity level on the display.

8.8 Setting the Security Access Option

The instrument is equipped with a security access option. If this option is turned on, the user must be able to input one of the three access codes used in the instrument: code 333 will provide access to instrument calibration, code 444 will provide access to instrument configuration, and code 555 will provide access to the OFFSET. See section 4.2 for more information on this security feature. The security button will be highlighted on this display at this time and the lower row of the display will indicate the operational status of the security access option (on or off).

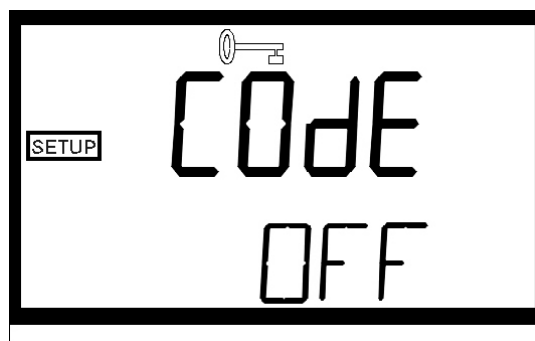

You can change the operational status of this option using the \blacktriangle and \blacktriangledown buttons. Once you have set the desired security code functionality, press the \blacktriangledown button to accept it. You will now see a screen with the word END on the lower row of the display.

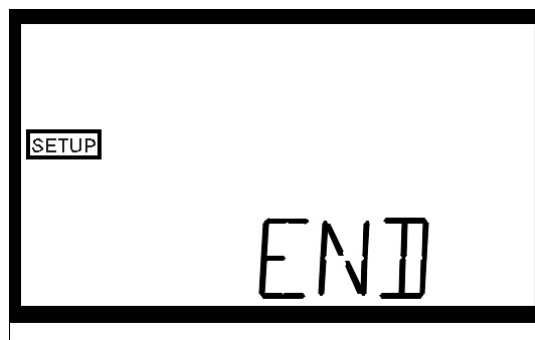

Pressing the ↵ button will return you back to the normal automatic mode of the instrument.

You have now completed the customer selectable parameters section of the instrument. You can enter this menu at any time to re-set, or change, any of the parameters.

9.0 Troubleshooting/System Alarm Relay

9.1 System Warning Message(s)

The instrument routinely performs self-diagnostics and will automatically generate warning messages to provide you with specific diagnostic information about the instrument. These are only messages and they do not indicate failure of any component in the instrument. Normally, the cause of a warning message is external of the instrument. The following table lists the warning messages and their associated meanings:

WARNING	ASSOCIATED MEANING	TYPICAL CAUSE
W01	Lamp failure	Lamp has too low an output or the 0.02 NTU calibration standard was contaminated. Attempt to recalibrate. If this does not remedy the problem, the lamp must be replaced followed by a recalibration.
W02	Calibration failure	The wrong standards were used in calibration or there is an internal sensor failure of the instrument.
W03	Analog loop failure	Analog loop connection is open. Verify your wiring if you are using the analog output. If not, turn off the option in the setup menu.
W04	Flow Error	If the flow switch is option installed, this indicates a loss of flow of process

WARNING	ASSOCIATED MEANING	TYPICAL CAUSE
		to the instrument. If the flow switch is not installed, turn off the option in the setup menu.
O-r	Sample Over-Range	The sample turbidity level is greater than the instrument will measure (either 11 NTU or 110 NTU depending on your model).
WNG	Multiple Warning conditions are met	A combination of warning conditions has been met. Typically, this condition arises when the setup for the analog output and the flow switch are not set correctly.

If any of the above conditions occurs, the message will be indicated on the lower row of the display.

9.2 System Error Message

The instrument will also automatically generate error messages. An Error message is generated when there is a significant problem found with the operation of the instrument. When this message is indicated, contact the HF scientific, inc. Technical Services department to determine a resolution to the problem. The instrument indicates an error message “SFE” if there is a general electronics failure. Normally, this condition indicates that the instrument will require servicing; contact either the HF scientific, inc. Technical Service Department or the HF scientific, inc. Customer Service Department.

If an error condition occurs, the system alarm relay will automatically be set to the alarm position, the analog output will be set to 2 mA and the ERROR block will be highlighted.

9.3 Technical and Customer Assistance

If for any reason you need assistance regarding this instrument please do not hesitate to contact either the HF scientific, inc. Technical Service Department or the HF scientific, inc. Customer Service Department:

HF scientific, inc.
3170 Metro Parkway
Fort Myers, Florida 33916-7597
Phone: (239) 337-2116
Fax: (239) 332-7643
Email: info@hfscientific.com

10.0 Routine Maintenance

10.1 Cleaning the Optical Chamber (Sample Tube)

Proper measurement of turbidity requires that the sample tube be free of debris. Cleaning the sample tube is accomplished by first purging the system:

1. Stop the flow of sample water to the TVT.
2. Remove the cleanout plug and then clean the interior of the sample tube with the brush provided in the HF scientific, inc. calibration kit. If necessary, you may use any common non-abrasive detergent to help in the removal of any residual buildup on the sample tube.
3. Allow the sample tube to drain and then re-attach the flow of sample water to the TVT. Allow enough sample water to flow through the instrument to achieve a stable reading prior to placing the TVT back into routine operation.

10.2 Replacing the Desiccant Cartridge

Proper use of the supplied desiccant cartridge is essential in maintaining the performance of the instrument. The desiccant cartridge has been designed to have a long life. Replacement of the desiccant cartridge may be needed if water enters the enclosure, or if the enclosure is opened for an extended period. It is also essential that all enclosure seals are maintained. The desiccant cartridge should be replaced when the color of the desiccant (as viewed through the sight glass) has turned pink.

The desiccant cartridge is located on the lower right side of the front display of the instrument (see Figure 6). To remove the old desiccant cartridge, simply unscrew the cartridge from the front of the case by rotating the cartridge counter-clockwise (see Figure 6). Once removed, place the new cartridge into the instrument with the reverse movements. Then continue using the instrument as normally instructed.

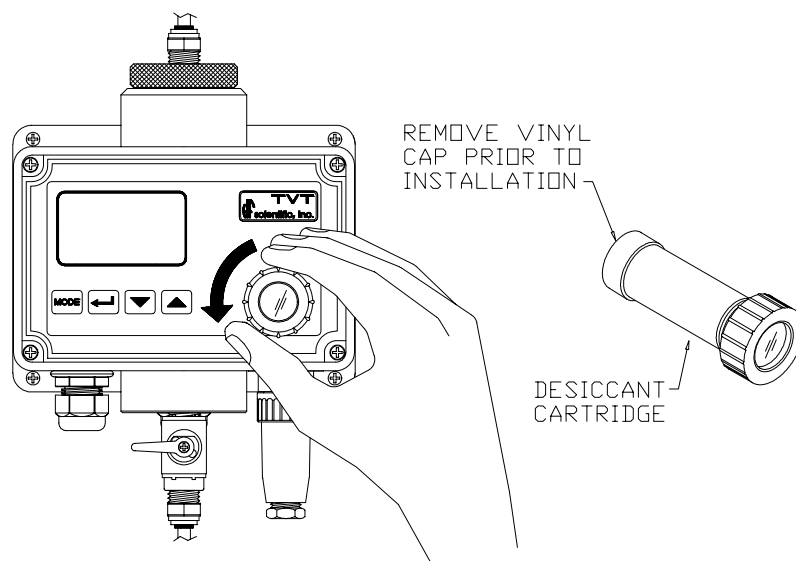

Figure 6: Removal of the Desiccant Cartridge

11.0 Accessories and Replacement Parts List

The items shown below are recommended accessories and replacement parts.

Accessory	Catalog Number	
	White Light	Infrared
HF Sure Cal check standard, Reuseable	19780	19780
Calibration Kit, 0.02 and 10 NTU Standards, 1 liter each	19781	19782
Calibration Kit for extended range calibration. Includes 10 and 100 NTU Standards, 1 Liter each.	19933	19996
Formazin Stock Solution, 4000 NTU, 500 mL	70914	70914
Flow Alarm to detect insufficient flow	19945	19945
Remote Display for an additional digital readout	19609	19609
Software for data collection and reporting	19782	19782

To order any accessory or replacement part, please contact the HF scientific, inc. Customer Service Department. If for any reason you need technical assistance regarding this instrument please do not hesitate to contact the HF Technical Services Department. See section 9.3 for contact information.

12.0 Warranty

HF scientific, inc., as vendor, warrants to the original purchaser of this instrument that it will be free of defects in material and workmanship, in normal use and service, for a period of one year from date of delivery to the original purchaser. HF scientific, inc.'s, obligation under this warranty is limited to replacing, at its factory, the instrument or any part thereof. Parts, which by their nature are normally required to be replaced periodically, consistent with normal maintenance, specifically lamps including fluorescent backlight, reagent, desiccant, sensors, electrodes and fuses are excluded. Also excluded are accessories and supply type items.

Original purchaser is responsible for return of the instruments, or parts thereof, to HF scientific, inc.'s factory. This includes all freight charges incurred in shipping to and from HF scientific, inc.'s factory.

HF scientific, inc. is not responsible for damage to the instrument, or parts thereof, resulting from misuse, negligence or accident, or defects resulting from repairs, alterations or installation made by any person or company not authorized by HF scientific, inc.

HF scientific, inc. assumes no liability for consequential damage of any kind, and the original purchaser, by placement of any order for the instrument, or parts thereof, shall be deemed liable for any and all damages incurred by the use or misuse of the instruments, or parts thereof, by the purchaser, its employees, or others, following receipt thereof.

Carefully inspect this product for shipping damage, if damaged, immediately notify the shipping company and arrange an on-site inspection. HF scientific, inc. cannot be responsible for damage in shipment and cannot assist with claims without an on-site inspection of the damage.

This warranty is given expressly and in lieu of all other warranties, expressed or implied. Purchaser agrees that there is no warranty on merchantability and that there are no other warranties, expressed or implied. No agent is authorized to assume for HF scientific, inc. any liability except as set forth above.

HF scientific, inc.
3170 Metro Parkway
Fort Myers, Florida 33916-7597
Phone: (239) 337-2116
Fax: (239) 332-7643