

FLOWRITE II®**HEAVY DUTY BRONZE GLOBE CONTROL VALVES****DB****POWERS**

A WATTS INDUSTRIES CO.

DOUBLE SEAT BRONZE BODY — HIGH CAPACITY

- ▶ 1", 1-1/4", 1-1/2", and 2" Union Ends
- ▶ ANSI Class 250 Body Rating
- ▶ ANSI Class II Close off
- ▶ Bronze or Stainless Steel Trim
- ▶ Linear Flow Characteristic
- ▶ 46" Pneumatic Diaphragm Field Reversible Actuator
- ▶ Stainless Steel Hardware
- ▶ NAMUR Standard Yoke for Accessories

DESCRIPTION

The rugged Powers Type DB (double seat bronze body) valve is primarily used for steam and water modulating applications that have capacity or pressure drop requirements beyond the capabilities of single seat valves.

Additionally, the self-balancing characteristic enables double seat valves to use smaller actuators than single seat valves. The DB should *not be used* on applications where

tight close-off is required (such as instantaneous water heaters). Bronze and stainless trim are available, with stainless recommended for applications over 50 PSI. The DB's control and close off characteristics are particularly well-suited to applications requiring high capacity and tolerating Class II close off.

DIMENSIONAL INFORMATION (For other sizes consult factory)

Pneumatic Actuators

Actuator*	A	B	lbs.
46"	10"	10-3/8"	14

Valve Body

Size	C	D	E	lbs.
1"	6-5/8"	2-1/8"	3-5/8"	7
1-1/4"	7"	2-7/18"	3-5/8"	9
1-1/2"	7-7/8"	2-9/16"	3-3/4"	10
2"	9-7/32"	3-5/8"	4-13/16"	21

*See Actuator Select Tables on page 5.

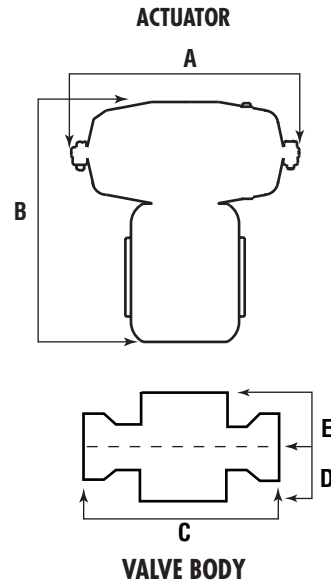

APPLICATION

To properly size a valve either follow these criteria or use the PowerSize® valve sizing program available at www.powerscontrols.com.

- **Body Material and Rating.** Bronze body, ANSI Class 250, union ends, 1"–2". Refer to Body Temperature/ Pressure Ratings table to insure your application fits in the acceptable operating range. Also determine that the valve body material is compatible with your media.
- **Trim Material.** Select bronze or stainless for applications under 50 PSI; select stainless only above 50 PSI.
- **Flow Coefficient (CV Rating).** Refer to PowerSize Valve Sizing Program or specifying engineer's data to determine Cv. Select a valve size that most closely matches the calculated Cv from the Flowing ΔP , Close Off ΔP , and Cv Ratings table.
- **Flowing Pressure Drop (ΔP).** To avoid cavitation and its accompanying trim damage, the following operating ΔP limits should be observed.
- **Liquid service.** ΔP less than the quantity $(0.66 \times \text{inlet pressure}) + 10$. Additionally, flowing ΔP should not exceed 100 PSI.

BODY TEMPERATURE/PRESSURE RATINGS

ANSI Standard Ratings—Bronze Bodies

Temperature (°F)	Class 250 Lb. (psig)
–20 to 150	400
200	385
250	365
300	335
350	300
400	250

- **Steam service.** ΔP less than the quantity $(0.5 \times \text{inlet pressure}) + 7.35$. Additionally, flowing ΔP should not exceed 100 PSI.
- **Actuator Selection.** The actuator must have enough force to close off against line pressure or maximum ΔP . The 3–15 and 1–17 columns in the Close Off ΔP and Cv Ratings table apply to valves with control signals coming directly from I/P transducers. The 0–30 column applies to valves using Accritem® type pneumatic controllers or valves equipped with a positioner or 0–30 PSI I/P transducer. If your close off ΔP exceeds the value in the table, it will be necessary to evaluate the use of an in-line shutoff valve or alternate control valve meeting your close-off ΔP requirements.

Type DB CLOSE OFF Δ P AND CV RATINGS

Valve Size	CV Rating	Plug Travel	Actuator Codes	Maximum Δ P in PSI at Close Off					
				Fail Closed			Fail Open		
				Signal to Actuator			Signal to Actuator		
				Pneumatic Actuator	PNEUMATIC			PNEUMATIC	
3-15 PSI	1-17 PSI	0-30 PSI	3-15 PSI		1-17 PSI	0-30 PSI			
1	14	3/16	46 / 4C	125	125	125	125	125	125
1-1/4	22	1/4	46 / 4C	125	125	125	125	125	125
1-1/2	28	1/4	46 / 4C	125	125	125	125	125	125
2	58	3/8	46 / 4C	125	125	125	125	125	125

NOTE: Stainless Steel trim should be used for all pressures over 50 PSI

SIZING REFERENCE

STEAM TABLE

Steam Pressure PSIG	Temp. °F	Temp. °C	Sensible Heat BTU/lb.	Latent Heat BTU/lb.	Total Heat BTU/lb.
0	212	100	180	971	1151
10	239	115	207	952	1159
25	266	130	236	934	1170
50	297	147	267	912	1179
75	320	160	290	896	1186
100	338	170	309	881	1190
125	353	178	325	868	1193
150	365	185	339	858	1197
200	387	197	362	838	1200
250	406	208	381	821	1202
300	422	217	399	805	1204
400	448	231	438	778	1216
500	470	243	453	752	1205
600	489	254	475	729	1204

RECTANGULAR TANK CAPACITY IN GALLONS

$$\text{Gallons} = \frac{\text{Height} \times \text{Width} \times \text{Length (inches)}}{230}$$

or

$$\text{Gallons} = H \times W \times L(\text{ft.}) \times 7.5$$

CIRCULAR TANK STORAGE CAPACITY IN GALLONS

$$\text{Storage} = 6D^2 \times L \text{ (Gallons)}$$

Where: D = tank diameter in Feet
L = length in Feet

LOAD SIZING CALCULATIONS

Heating Water with Steam

Quick Method

$$\text{Lbs. /hr.} = \frac{\text{GPM}}{2} \times \Delta T$$

Accurate Method

$$\text{Lbs. / hr.} = \frac{\text{GPM} \times 500 \times \Delta T}{h_{fg}}$$

Heating or Cooling Water with Water

$$\text{GPM}_1 = \text{GPM}_2 \times \frac{\text{°F water}_2 \text{ temp rise or drop}}{\text{°F water}_1 \text{ temp rise or drop}}$$

Heating or Cooling Water

$$\text{GPM} = \frac{\text{BTU/hr.}}{(\text{°F water temp. rise or drop}) \times 500}$$

Heating Oil with Steam

$$\text{Lbs. /hr.} = \frac{\text{GPM}}{4} \times (\text{°F oil temp. rise})$$

Heating Air with Water

$$\text{GPM} = 2.16 \times \frac{\text{CFM} \times (\text{°F air temp. rise})}{1000 \times (\text{°F water temp drop or rise})}$$

Heating Liquids with Steam

$$\text{Lbs. / hr.} = \frac{\text{GPM} \times 60 \times \text{CP} \times \text{W}}{h_{fg}} \times \Delta T$$

Heating Liquids in Steam Jacketed Kettles

$$\text{Lbs. / hr.} = \frac{\text{GPM} \times \text{Cp} \times \text{S} \times 8.33}{h_{fg} \times t} \times \Delta T$$

General Liquid Heating

$$\text{Lbs. / hr.} = \frac{\text{W} \times \text{Cp}}{h_{fg} \times t} \times \Delta T$$

Heating Air with Steam

$$\text{Lbs. / hr.} = \frac{\text{CFM}}{900} \times \Delta T$$

GLOSSARY OF TERMS

- t** = Time in Hours
- Cp** = Specific Heat of Liquid
- S** = Specific Gravity of Fluid
- W** = Weight in Lbs.
- ΔT** = Temperature rise of fall in °F
- h_{fg}** = Latent Heat of Steam

CONVERSION FACTORS

- 1 lb. Steam/Hr.** = 1000 BTU/Hr.
- 1 Cubic Meter** = 265 U.S. Gallons
- 1 Cubic Foot Water** = 62.4 lbs.
- 1 PSI** = 2.04 inches of Mercury
- 1 PSI** = 2.3 feet of Water
- 1 PSI** = 27.7 inches of Water
- 1 U.S. Gallon Water** = 231 Cubic inches
- 1 U.S. Gallon Water** = 8.33 lbs.

ORDERING INFORMATION

593- **D** **B**

Size	Order Code																							
1"	100																							
1-1/4"	125																							
1-1/2"	150																							
2"	200																							
End Connections																								
Screwed	S																							
Valve Trim																								
Bronze	B																							
Stainless	S																							
Action																								
Fail Open (Air-to-Close)	X																							
Fail Closed (Air-to-Open)	C																							
Packing																								
Teflon V-Ring	S																							
EPV-Ring	W																							

**ACCESSORIES
SELECT CODE**
(see page 6)

**ACTUATOR
SELECT CODE**
(see below)

ACTUATOR SELECT CODE

CODE	PNEUMATIC DIAPHRAGM ACTUATORS
46	46 Sq. In., 1" Max Valve Stroke with Standard Springs, adjustable start w/ 7 ~ 12 lb. Fixed span.
4C	46 Sq. In., 1" Max Valve Stroke with Extreme Cycle Springs, adjustable start w/ 7~ 12 lb. Fixed span.

ORDERING INFORMATION *(cont'd.)*

ACCESSORIES SELECT CODE

BELLOFRAM 1000 I/P'S		UTILITY POSITIONER AND I/P		NO ACCESSORIES	
Code	Description	Code	Description	Code	Description
IS	3–15 psi	BS	4–20 mA	OS	No accessories
TS	1–17 psi	UTILITY POSITIONER			
US	3–27 psi	Code	Description		
CONTROL/AIR TYPE 900X I/P		PS	3–15 PSI		
Code	Description	RS	3–9 PSI		
ES	0–30 psi	SS	9–15 PSI		

I/P TRANSDUCERS

The “standard” 3–15 psi signal was originally designed as a transmission signal, not a valve actuation signal. Unbalanced control valves have their operational limits lowered when forced to operate with this 3–15 psi signal. The Fluid Controls Institute (in Standard 87-2) has recommended that a 1–17 psi air signal range be used when directly actuating a control valve without a positioner. Powers concurs with this recommendation, and therefore, offers a 1–17 psi I/P transducer and a 0–30 psi I/P transducer for maximum close-off. 3–15 psi I/P transducers should be used in conjunction with positioners.

POSITIONERS

Positioners are used for one or more of the following reasons:

- 1) To split range valves.
- 2) To eliminate unwanted valve movement caused by line pressure variations
- 3) To minimize the effects of “stick-slip”
- 4) To speed response time and/or
- 5) To increase close-off rating when I/Ps are used.

CALCULATION/SKETCH AREA

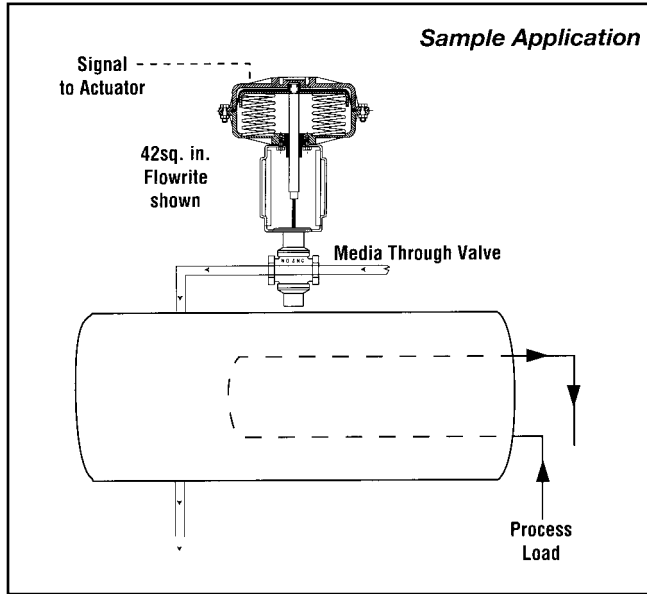

Considerations: _____

Medium: _____

Capacity: _____

Inlet Pressures: _____

Pressure Drop: _____

Temp.: (Packing): _____

Fail Safe: _____

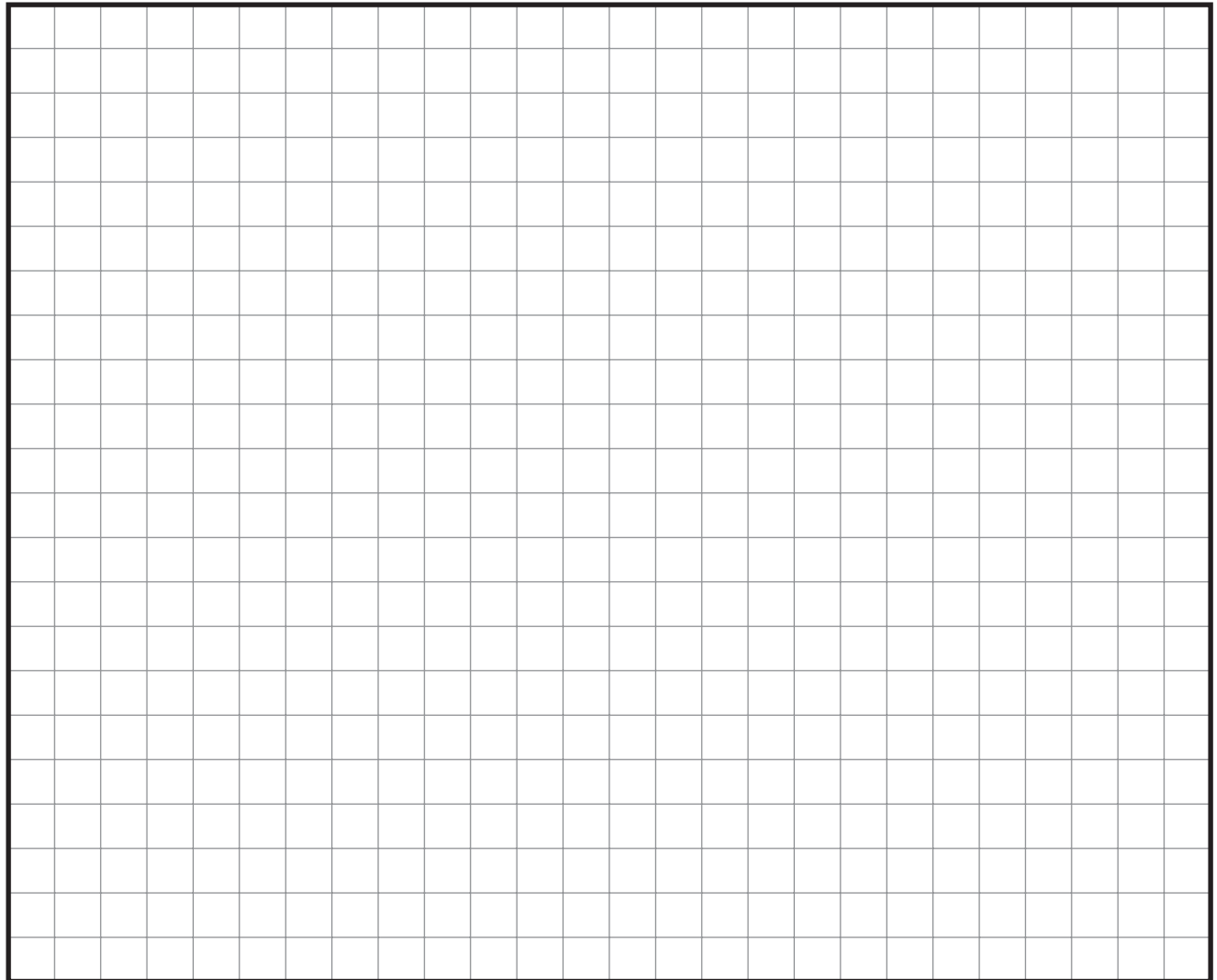



For more information on FLOWRITE II® or other quality Powers products,
visit us at our website powerscontrols.com.

Pneumatic Temperature Controllers

Temperature Regulators

Mixing Valves

Control Valves

Now available, a fast easy way to size a valve... PowerSize®.

A free software solution available at
www.powerscontrols.com or through any
Powers sales representative.

POWERS

A WATTS INDUSTRIES CO.
www.powerscontrols.com

USA office: Phone: 800.669.5430 • Fax: 847.824.0627
Canadian office: Phone: 888.208.8927 • Fax: 888.882.1979

© 2002 Powers, a Watts Industries Co.