

## Stainless Series

S127-31 or S6127-31 (Globe)  
S1127-31 or S61127-31 (Angle)

- Designed for Tank Fill and Discharge applications
- Opens when Tank head pressure is below setpoint
- Closes when Tank head pressure is above setpoint
- Opens for return flow when upstream system pressure is below Tank head pressure
- Solenoid (On-Off) Feature provides electrical override of Tank Fill function
- Tank Sense Line is field installed (to Tank or standpipe)
- Adjustable Opening and Closing Speed
- Altitude setpoint is adjustable

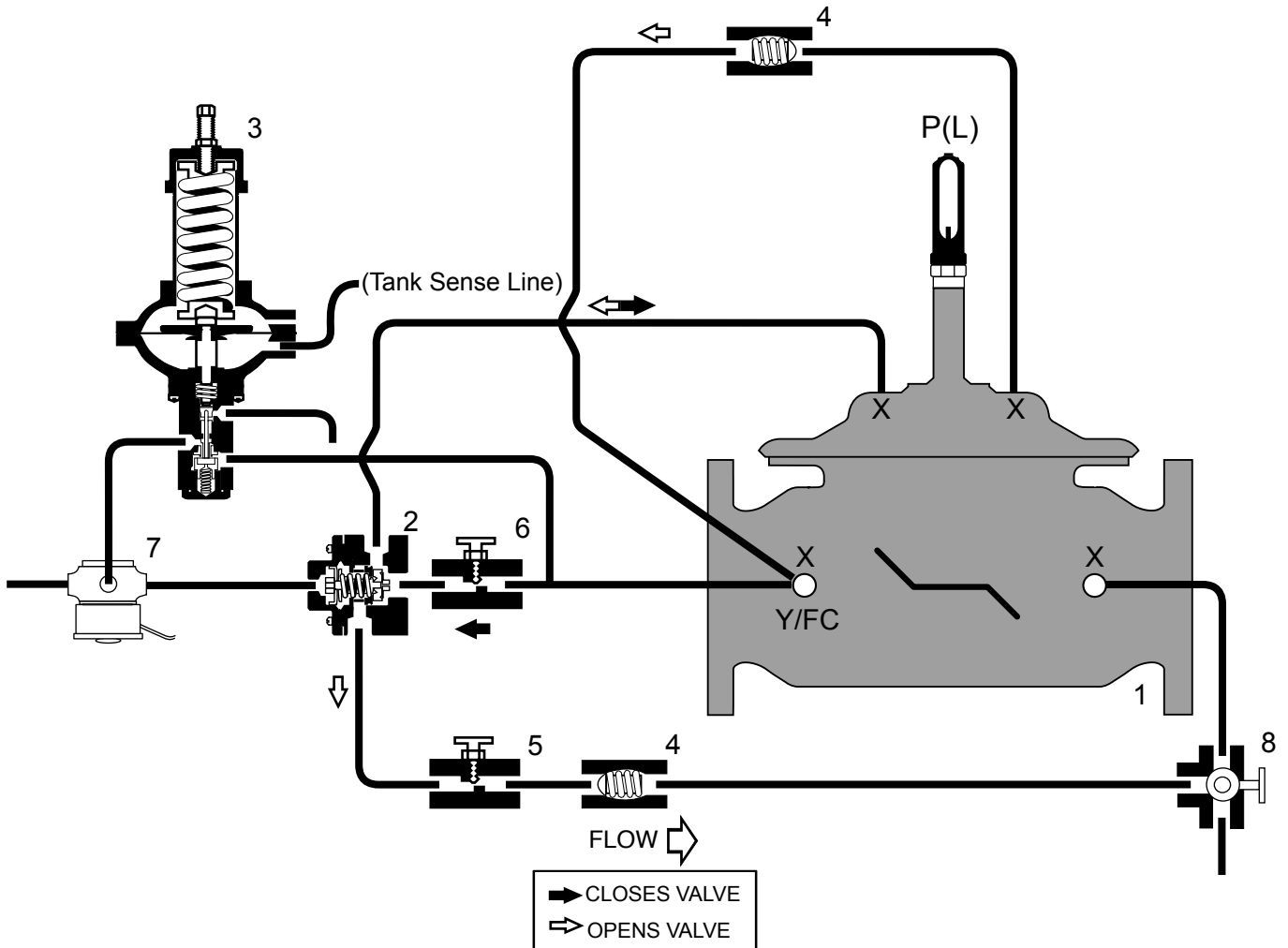

### STANDARD COMPONENTS

- 1 - Main Valve (Single Chamber)
- 2 - Fig. 22-1 Accelerator Control
- 3 - Altitude Control
- 4 - Check Valve
- 5 - Adjustable Opening Speed
- 6 - Adjustable Closing Speed
- 7 - 3-Way Solenoid
- 8 - 3-Way Ball Valve
- P - Position Indicator

### OPTIONS and ACCESSORIES

- X - Isolation Cocks
- FC - Flo-Clean Strainer
- Y - Y-Strainer (Replaces Flo-Clean)
- L - Limit Switch