

Installation, Operation and Maintenance Manual



QT™ Brew Max™ Models:
 QTBRWMAX-1S-1M, QTBRWMAX-2S-1M



QTBRWMAX-2S-1M



Tested and Certified by WQA against NSF/ANSI 372 for Lead Free compliance.

⚠ WARNING



Read this Manual BEFORE using this equipment. Failure to read and follow all safety and use information can result in death, serious personal injury, property damage, or damage to the equipment. Keep this Manual for future reference.



⚠ WARNING

You are required to consult the local building and plumbing codes prior to installation. If the information in this manual is not consistent with local building or plumbing codes, the local codes should be followed. Inquire with governing authorities for additional local requirements.

Table of Contents

System Specifications	2
Replacement Filters	2
Notice to Installers	2
Installation Precautions	2
Operation	2
Installation	2
Maintenance	3
Replacement Parts List	3
System Drawings	3
Limited Warranty	4

⚠ WARNING

Do not use with water that is microbiologically unsafe or of unknown quality without adequate disinfection before or after the system.



System Specifications

Maximum Pressure:
All Systems - 100psi (6.8 bar)

Minimum Pressure:
All Systems - 20psi (1.4 bar)
Maximum Temperature: 100°F (38°C)
Minimum Temperature: 40°F (4.4°C)
Feed Water Quality: pH 6.5 to 8.5

Chlorine < 2ppm
Iron (maximum) 0.3 mg/l
Manganese (maximum) 0.05 mg/l
Oil & H₂S- None allowed

For all other feed water quality requirements abide by the current USEPA Safe Drinking Water Act standards.

Inlet/Outlet Connections: 3/8" (10mm) NPT for model QTBRWMAX-1S-1M. QTBRWMAX-2S-1M has 1/2" (15mm) NPT connections

Maximum Flow Rate:

System Flow Rate and Capacity		
System Model	Flow Rate	Chlorine Capacity
QTBRWMAX-1S-1M	1.5 GPM (5.7 LPM)	10,000 Gallons
QTBRWMAX-2S-1M	3 GPM (11.4 LPM)	20,000 Gallons

QT Brew Max line is available in different configurations depending upon filtration and flow requirements.

Replacement Filters

System Replacement Filters			
System Model	Filter Ordering Code	Frequency	Description
QTBRWMAX-1S-1M	QTBR15S*	6 Months	15" 1 Micron Carbon Block for Lead Reduction with Phosphate Scale Control
QTBRWMAX-2S-1M	QTBR15	6 Months	15" 1 Micron Carbon Block for Lead Reduction with Phosphate Scale Control (2)

NOTICE

Filter cartridges should be changed at end of filter life, due to lack of filtering performance, or whenever a 15 psi pressure drop or greater is experienced during normal operation, whichever comes first.

For all replacement filters and components contact your authorized Hydro-Safe Foodservice representative.

*Note: The QTBR15S is the same filter as the QTBR15. Only the label position has been changed so that the label faces forward on single cartridge systems.

NOTICE

Cartridge capacities are estimates and may be less depending on incoming water quality.

Notice to Installer

- Connect the system to cold water supply only. Water Temperature cannot exceed 100°F (38°C).
- System must be installed in a vertical, upright and level position.
- Do not use with water that is microbiologically unsafe or of unknown water quality.
- Notice to user/owner/operator: Please retain this manual for future reference for parts, maintenance, or troubleshooting.
- It is recommended that all personnel responsible for operation and maintenance of this product read the precautions, maintenance, and operation sections of this manual.

Installation Precautions

- Do not install system on line pressure above the rated pressure as noted in System Specifications above.
- Do not install the system on a hot water line. Failure to limit the water temperature to 100°F (38°C) can result in housing failure and property damage.
- Do not connect the system backwards with the feed water line connected to the outlet.
- Do not use liquid pipe thread compounds for threaded connections. Use Teflon® tape only.
- Do not solder plumbing connections that are attached to the housings or inlet/outlet fittings. System damage may occur due to high temperature.
- Do not allow the system to freeze. Turn off water supply and drain the system if temperature falls below 32°F (0°C).
- Do not install system in direct sunlight or where the system will be exposed to harsh chemicals or may be subjected to being hit by moving equipment, carts, mops, or any other item that may cause damage.
- Allow 3" (76mm) minimum clearance under the housings for filter replacement.
- If water hammer is evident, install water hammer arrestors before the system.
- Do not over tighten fitting connections.
- Always back up valves and fittings with a wrench when installing fittings to avoid over tightening or loosening existing fittings.
- Do not install the unit behind equipment where it may be difficult to access the system for future filter replacements.

Position the system in a suitable location. The direction of flow through the system is left to right. Keep this in mind when determining installation locations. Do not mount the system near any source of heat. Also do not mount this system over anything that may be adversely affected by water.

Operation

With sufficient pressure, operation of this system is completely automatic. Dependable operation involves only monitoring system pressure differential, periodic filter changes, and service documentation.

Installation

There is some light field assembly required for this system. Before beginning the installation of this system, please make sure all components are present. Compare the contents of this box to the system drawings located at the end of this manual. As illustrated by the drawings, not all systems utilize pressure gauges. These drawings will be referenced in the installation instruction steps.

NOTICE

1. Turn off all equipment to be fed by the system, locate the water supply shutoff valve and turn it off.
2. Apply Teflon tape to the threads of the inlet and outlet valve and pressure gauges (if supplied for your model). **DO NOT USE PASTE TYPE THREAD SEALANT.** Thread the inlet and outlet valve assemblies into the inlet and outlet ports of the system as shown on the system drawings in this manual. Install the pressure gauges, if applicable, into the gauge ports as indicated by the system drawings in this manual.

NOTICE

DO NOT OVER TIGHTEN THESE FITTINGS INTO THE FILTER HEADS. When installing fittings onto this system, back any existing receiving fittings with a wrench to prevent fitting movement. Use a wrench to tighten gauges into their connection ports. Do not twist on gauge case.

3. Install the filters into the filter manifold. Make sure all plastic wrapping and protective plastic caps have been removed from the filters prior to their installation. To install these filters, push them into the filter manifold and give them a quarter twist (clockwise when viewed from below). When the filter is completely inserted, the cartridge label will be front centered.
4. Anchor the system on a wall stud or suitable mounting materials spanning wall studs. System must be vertical, upright and level. The mounting hardware used must be selected and installed so that the system is firmly pressed against the mounting surface. The system mounting hardware must keep the system from moving during routine service and operation.
5. Run a suitable line from the tap water source to the inlet ball valve on the left side of the system. Brace the inlet ball valve on the system with a wrench when connecting the feed water line.

NOTICE

DO NOT OVERTIGHTEN CONNECTION FITTING INTO BALL VALVE.

6. Select the appropriate size tubing for the equipment being fed, and connect it to the outlet ball valve of the system.

NOTICE

DO NOT OVERTIGHTEN CONNECTION FITTING INTO BALL VALVE.

7. Install the 1/4" (8mm) tubing into the Quick-Connect fitting on the outlet of the system and hold it over a drain. Open the 1/4" (8mm) drain valve.
8. Once all inlet and outlet piping has been completed, check and make sure all filter housing(s) are tight, slowly open the inlet valve and allow all air to purge from the system through the 1/4" tubing. Slowly close the 1/4" (8mm) drain valve, allow the system to reach operating pressure, and check for leaks.
9. If no leaks are present, open the 1/4" (8mm) drain line again and allow it to run to drain for 5 minutes to flush the system then close the valve.
10. Open the outlet water valve and check for leaks.
11. Record the start up date and pressure gauge values in system maintenance log.

NOTICE

Overtightening components can damage the system causing water damage and/or system failure.

Maintenance

Routine maintenance of this system involves periodic filter changes.

Filter cartridges should be changed at end of filter life, due to lack of filtering performance, or whenever a 15psi pressure drop or greater is experienced during normal operation, whichever comes first.

Filter Cartridge Replacement Procedure

WARNING

Determine whether all equipment connected to the system must be turned off prior to shutting off water supply from filters.

1. If required, turn off downstream equipment.
2. Turn OFF water to the system by closing the inlet and outlet ball valves.
3. Open the 1/4" drain valve on the outlet of the system to relieve pressure in the housings.
4. Remove all filters. The QT style filters are removed by rotating them 1/4 turn to the left and then gently pulling down.
5. Insert new QT style filters into the manifold assembly. Push up and twist each QT cartridge 1/4 turn to the right to properly install it into the manifold assembly. When making the 1/4 turn, the cartridge label should come to a stop facing you.

Do not overtighten filter housing, overtightening may damage O-ring(s), cause water leaks, or affect system performance.

6. Slightly open the inlet ball valve and fully open the 1/4" drain valve. Once full flow of water flows from the drain port, slowly open the inlet valve to the full open position. Allow water to flush to drain for 5 minutes.
7. Slowly close the drain valve and check the system for leaks.
8. Slowly open the outlet valve to restore water flow to downstream equipment.
9. Record filter change date in system maintenance log.

Teflon® is a registered trademark of E.I. DuPont de Nemours & Company.

Replacement Parts

Description	Ordering Code
Filter Head 3/8" Top In/Out Quick Connect	HSR-QTHD-QC38
Filter Head 3/8" Side In/Out FNPT	HSR-QTHD-TT38
Manifold Head First Stage With NPT Inlet	HSR-QTMHF-NPT
Manifold Head Last Stage	HSR-QTMHL
Ball Valve 3/8 NPT	HSR-BV3/8
Ball Valve 1/4 NPT Plastic	HSR-BV1/4P
Ball Valve 1/4 NPT Brass	HSR-BV1/4PLH
Ball Valve 1/2 NPT	HSR-BV1/2
Outlet Back Mount Pressure Gauge	HSR-GAUGE-BKM

QTBRWMAX-1S-1M

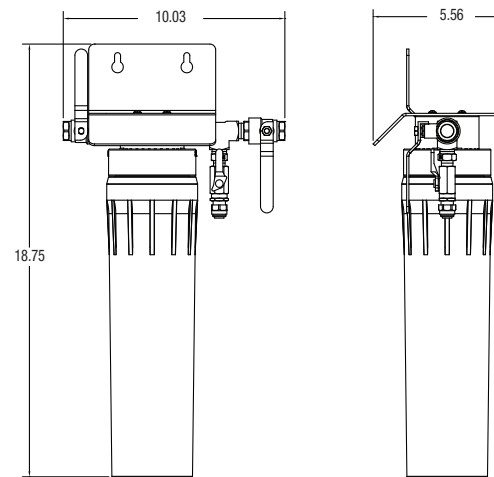

QTBRWMAX-2S-1M

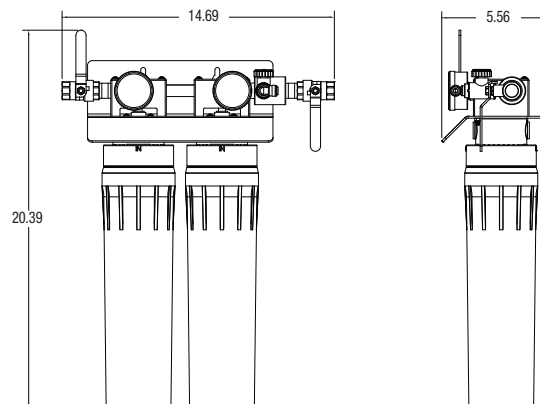

NOTICE

Allow 3" (76mm) of clearance at bottom of system for removal of filter bowls for filter cartridge replacement

WARNING: This product contains chemicals known to the State of California to cause cancer and birth defects or other reproductive harm.
For more information: www.watts.com/prop65

LIMITED WARRANTY: Watts Regulator Co. (the "Company") warrants each QT Brew Max water filtration line system, excluding filters and water treatment cartridges, to be free from defects in material and workmanship under normal usage for a period of five years from the date of original shipment. The Company warrants all filters and water treatment cartridges to be free from defects in material and workmanship under normal usage for a period of one year from the date of original shipment. In the event of such defects within the warranty period, the Company will, at its option, replace or recondition the product without charge.

THE WARRANTY SET FORTH HEREIN IS GIVEN EXPRESSLY AND IS THE ONLY WARRANTY GIVEN BY THE COMPANY WITH RESPECT TO THE PRODUCT. THE COMPANY MAKES NO OTHER WARRANTIES, EXPRESS OR IMPLIED. THE COMPANY HEREBY SPECIFICALLY DISCLAIMS ALL OTHER WARRANTIES, EXPRESS OR IMPLIED, INCLUDING BUT NOT LIMITED TO THE IMPLIED WARRANTIES OF MERCHANTABILITY AND FITNESS FOR A PARTICULAR PURPOSE. The remedy described in the first paragraph of this Limited Warranty shall constitute the sole and exclusive remedy for breach of warranty, and the Company shall not be responsible for any incidental, special or consequential damages, including without limitation, lost profits or the cost of repairing or replacing other property which is damaged if this product does not work properly, other costs resulting from labor charges, delays, vandalism, negligence, fouling caused by foreign material, damage from adverse water conditions, chemical, or any other circumstances over which the Company has no control. This warranty shall be invalidated by any abuse, misuse, misapplication, improper installation or improper maintenance or alteration of the product. Some States do not allow limitations on how long an implied warranty lasts, and some States do not allow the exclusion or limitation of incidental or consequential damages. Therefore the above limitations may not apply to you. This Limited Warranty gives you specific legal rights, and you may have other rights that vary from State to State. You should consult applicable state laws to determine your rights. **SO FAR AS IS CONSISTENT WITH APPLICABLE STATE LAW, ANY IMPLIED WARRANTIES THAT MAY NOT BE DISCLAIMED, INCLUDING THE IMPLIED WARRANTIES OF MERCHANTABILITY AND FITNESS FOR A PARTICULAR PURPOSE, ARE LIMITED IN DURATION TO ONE YEAR FROM THE DATE OF ORIGINAL SHIPMENT.**



T: (800) 264-1183 • F: (724) 733-4808 • foodservice.watts.com