

# FREEZE PROTECTION MODEL 825Y

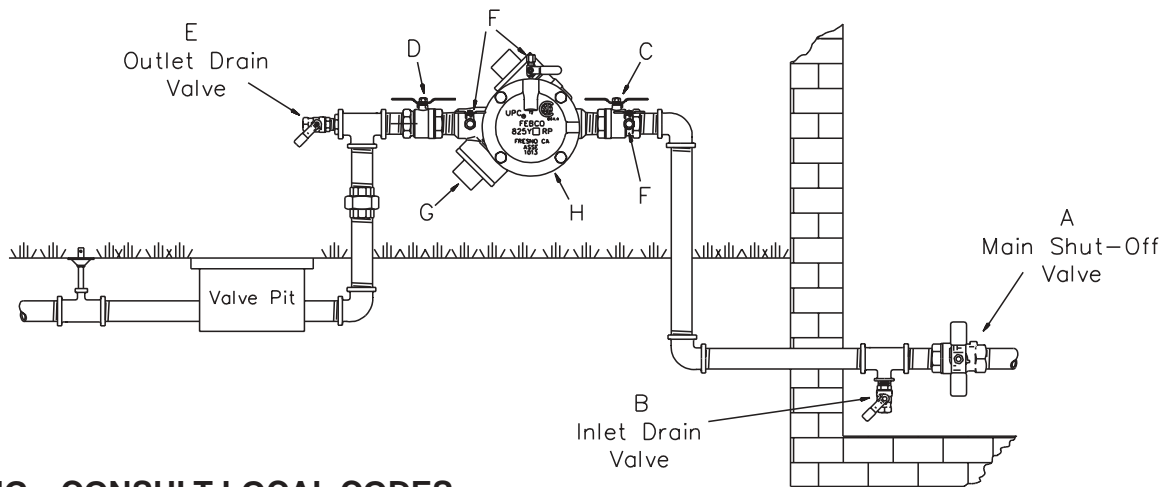

## Reduced Pressure Assembly Draining Procedure for Freeze Protection



### WARNING—CONSULT LOCAL CODES PRIOR TO PERFORMING SERVICE AND DRAINING PROCEDURES!

Damage from freezing will be costly. FEBCO products are not warranted against freeze damage. The following instructions will protect against freezing of reduced pressure principle devices.

### FREEZE PROTECTION GUIDELINES

Backflow prevention assemblies must be protected against freezing for the winter in areas where freezing temperatures may occur. If the water inside the assembly freezes, damage to the assembly and the system may occur. Proper draining, insulation using heat tape and heated protective enclosures are all acceptable methods of freeze protection.

When draining an assembly to prevent freezing, several important points must be remembered:

1. The assembly cannot be adequately drained through the testcocks. For proper draining follow the instructions detailed in the Drain Procedure section below.
2. Drain valves must be added on the inlet and outlet sides of the assembly, below the assembly (and preferably below the freeze line if the remainder of the system is to be drained).

### DRAIN PROCEDURE

1. Close the main shut-off valve (A).
2. Open the inlet drain (B).
3. Open the inlet and outlet ball valves (C & D) 45° degrees (half open, half closed).

4. Open all testcocks (F)
5. Open the outlet drain (E).
6. Loosen the cover on the # 2 check valve (G) until all water drains.
7. Loosen the cover on the relief valve (H) to allow water on both sides of the diaphragm to drain.
8. If you “blowout” the piping downstream of the backflow assembly using compressed air:
  - Connect the air supply to the outlet drain (E) and close the outlet ball valve (D).
  - After clearing the system with air, partially open the outlet ball valve (D).
  - Leave all drain valves (E & B), testcocks (F) and ball valves (C & D) in a half open, half closed position for the winter. (See ball valve freeze protection instructions for more details.)
  - Make sure the main shut-off valve (A) remains closed and does not leak.

### SPRING “START-UP” PROCEDURE

When there is no more chance of freeze damage:

1. Close all drain valves (E & B), testcocks (F) and ball valves (C & D).
2. Retighten the relief valve cover (H), then slowly open the main shut off valve (A) and the inlet ball valve (C).
3. Slightly open, then close, all testcocks (F) one at a time to empty air from the device.
4. Slowly open the outlet ball valve (D) and refill the system.

#### FEBCO Backflow Prevention

An SPX Process Equipment Operation

3816 South Willow • Fresno, CA 93725

Email: febc@processequipment.spx.com • [www.spxpe.com](http://www.spxpe.com) • [www.FEBCOonline.com](http://www.FEBCOonline.com)



An SPX Process Equipment Operation

## Ball Valve Draining Procedure for Freeze Protection

### BALL VALVES Draining Procedure for Freeze Protection

Ball valves should be drained for the winter in areas where freezing temperatures may occur. Water will become trapped between the ball and valve body if the valve is left in either the full open or full closed position. If water should freeze between the ball and valve body, damage to the ball valve will occur.

After draining procedures on the backflow prevention assembly have been completed, all ball valves must be left in a half open / half closed (45° degree) position as shown in Figure A. Open the ball valve approximately 45° degrees while draining the pipeline and assembly to allow water between the ball and valve body to drain as shown in Figure B. Leave the ball valve in this position for the winter to prevent freeze damage.

The valve must be closed before the system can be repressurized.

**NOTE: Open and close ball valves *slowly* at all times to prevent damage to the system.**

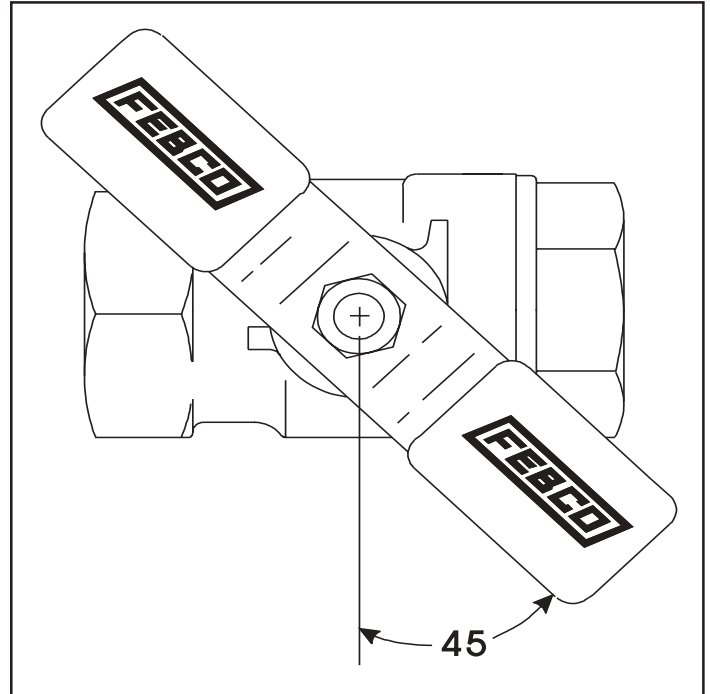

Figure A: Ball Valve in half open/half closed 45° degree position

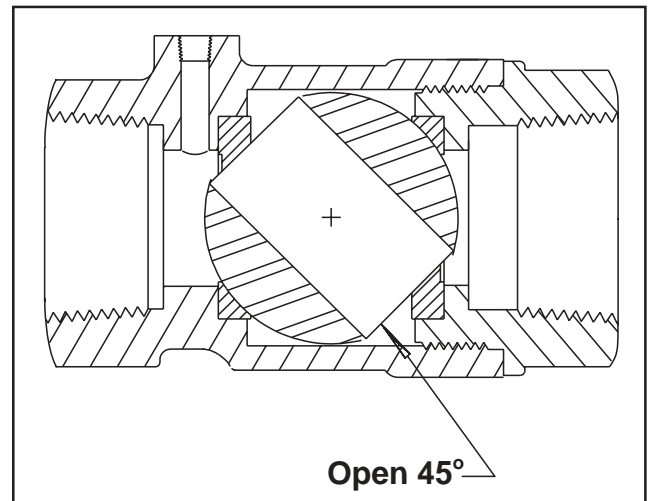

Figure B: Cutaway drawing displaying ball valve in half open/half closed position